

DC to 18 GHz, 10 W, N-Type Termination

DLNM-5010-18

ELECTRICAL SPECIFICATIONS:

Frequency range	DC – 18 GHz
Impedance	50 Ω
VSWR	≤1.30
Input AVG power	10 W @ 25 °C ambient
Power derating	linear to 1 W @ 100 °C
Peak power	500 W (5 μ-sec pulsed, 1% duty cycle)

MECHANICAL SPECIFICATIONS

Interface	N
Gender	Male
Standard	MIL-STD-348A
Weight	~65 g

MATERIAL SPECIFICATIONS

COMPONENT	MATERIAL	FINISHING
Connector	Brass	Ternary alloy
Center contact	Brass	Gold
Heatsink	Aluminium	Anodized black

ENVIRONMENTAL SPECIFICATIONS

Op. temperature	-55 / +100 °C
Storage temperature	-55 / +125 °C
RoHS	Compliant (2011/65/EU RoHS 3)
REACH	Compliant (EC 1907/2006)



KEY FEATURES

- DC to 18 GHz Wideband Operation
- Excellent Impedance Matching
- 10 W Continuous Power Handling
- 1-year Standard Warranty



DRAWING unit: mm

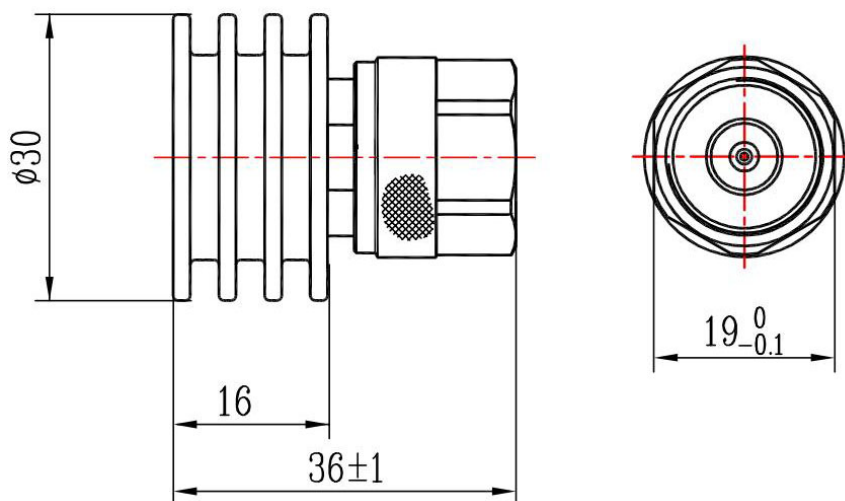

Notes:

1. Custom mechanical configurations and enhanced VSWR performance are available upon request.
2. For optimal electrical performance and reliability, forced-air cooling is recommended to maintain the case temperature below 85 °C.