

# 10 MHz to 6 GHz, BNC Inner DC-Block

DCB-BAXX-06

## ELECTRICAL SPECIFICATIONS:

Frequency range	0.01 – 6 GHz	
Impedance	50 Ω	
VSWR	≤1.25	
Insertion loss	≤0.5 dB	
DC input voltage	≤+50 V	DCB-BA50-06
	≤+100 V	DCB-BA100-06
	≤+250 V	DCB-BA250-06
Equivalent circuit		

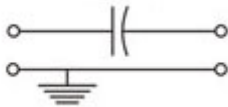

## MECHANICAL SPECIFICATIONS

Interface	BNC
Gender	Male – Female
Standard	MIL-STD-348A
Weight	~15 g

## MATERIAL SPECIFICATIONS

COMPONENT	MATERIAL	FINISHING
Body	Brass	Ternary alloy
Center contact	BeCu/Brass	Gold

## ENVIRONMENTAL SPECIFICATIONS

Op. temperature	-55 / +100 °C
RoHS	Compliant (2011/65/EU   RoHS 3)
REACH	Compliant (EC 1907/2006)

## KEY FEATURES

- 6 GHz Operation
- Up to 250 V DC Blocking with Low Insertion Loss
- BNC Interface for Microwave Systems
- 1-year standard warranty



## DRAWING unit: mm

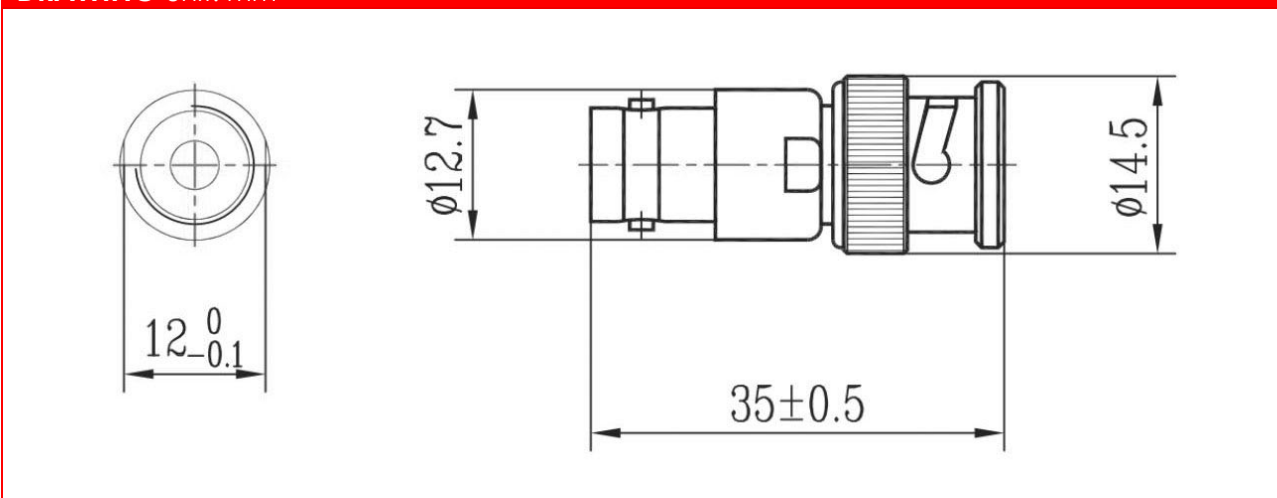

10 MHz to 6 GHz, BNC Inner DC-Block

DCB-BAXX-06

