

DATASHEET

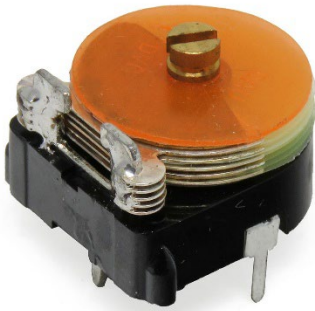

Voltage Rating	150 VDC
Test Voltage	300 VDC
Contact Resistance	$\leq 0.01 \text{ m}\Omega$
Insulation Resistance	$\geq 10.00 \text{ M}\Omega$
Rotation Torque	0.35 ... 3.5 Ncm
ΔC at max. axial load	2 N ($\leq 1.5\%$)
Life of Trimmer	maximum 10 cycles with 180°
Quality Level	0.15% for major defects 0.65% for minor defects
Dielectric	Polycarbonate (PC)
Capacitance Range	9 ... 200 pF
Q min. @ 1 MHz	200
TCC	0 \pm 300 ppm/°C
Operating Temp.	-40 ... +85 °C
H max.	13.8 mm

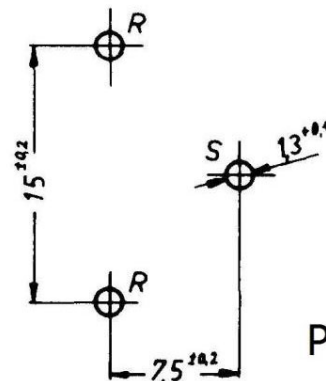
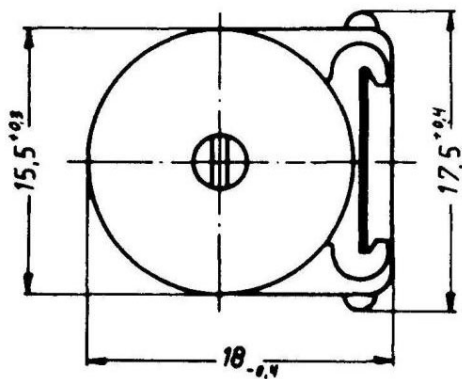
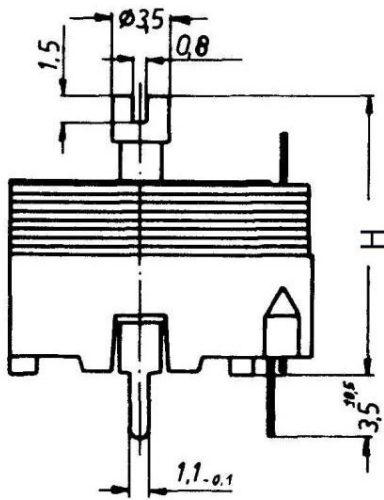

Pin Spacing