

DATASHEET

Electrical & Mechanical Specification

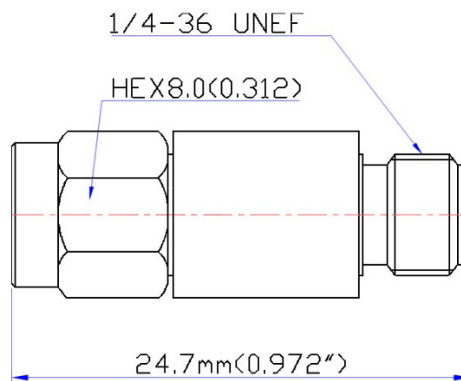

Frequency range	dc – 8 GHz
Attenuation	10 dB (±0.55 max.)
Power handling	2 W (bidirectional)
VSWR	1.20 (max.)
Impedance	50 Ω
Connectors	SMA male / female
Body material	Stainless steel
Body finish	Passivated
Center contact	Brass, BeCu / Gold plating
Insulator	PTFE



Attenuation & VSWR Vs. Frequency

