

1			2			3			4			5			6			7			8		
REVISIONS																							
ISS	ZONE	DESCRIPTION\PER REQUEST\DATE																					

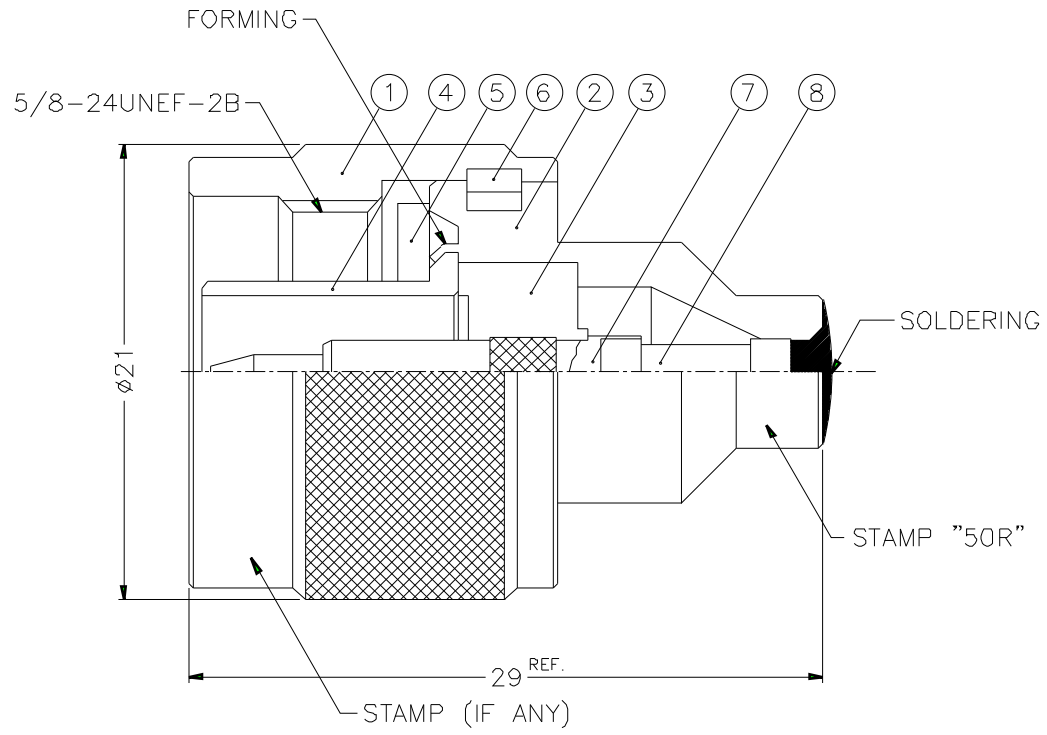

NOTES: FINISH (PLATING THICKNESS IN MICRO-INCHES)  
 1. BRASS PER QQ-B-626  
 2. NICKEL PL. 100 MIN. THICK OVER COPPER STRIKE  
 3. GOLD PL. 3 MIN. THICK OVER NICKEL PL. 100 MIN. THICK OVER COPPER STRIKE  
 4. TEFLON MIL-P-19468

RESISTOR TOLERANCE  
 50 ohm 1% 1Watt

8	RESISTOR	50R		1	ROD-50R-1W-1%	DIMENSIONS ARE IN MILLIMETERS				PART NO. N1004A2-NT3G-50R-0.01-1W		<b>Amphenol</b>	
7	CONTACT PIN	NOTE 1	NOTE 3	1	N1004A2-7-B	UNLESS OTHERWISE SPECIFIED TOLERANCES 0.5-6 = $\pm 0.2$ 6-30 = $\pm 0.4$ 30-120 = $\pm 0.6$ 120-315 = $\pm 1$ 315-1000 = $\pm 1.6$ 1000-2000 = $\pm 2.4$				APPROVED	DATE 10-11-01'		TITLE N TERMINATOR PLUG
6	RETAINER RING	SUS 304	NATURAL	1	N5000-7-C					CHECKED	DATE 10-11-01'		DRAWING NO. KJ-N1004A2-NT3G-50R-0.01-1W
5	GASKET	SILICONE	RED	1	GS-156/BX15					DRAWN	DATE 10-11-01'		ITEM NO.
4	CONTACT BODY	NOTE 1	NOTE 2	1	N5000-5W								
3	INSULATOR	NOTE 4	NATURAL	1	N1004A2-3								
2	BODY	NOTE 1	NOTE 2	1	N1004A2-2								
1	SHELL	NOTE 1	NOTE 2	1	N5000-1-B								
NO.	DESCRIPTION	MATERIAL	FINISH	Q'TY	DRAWING NO	SCALE	3/1	ISSUE	A	FILE NO.	DRAWING NO		

1			2			3			4			5			6			7			8		
---	--	--	---	--	--	---	--	--	---	--	--	---	--	--	---	--	--	---	--	--	---	--	--