

Jennings High-Voltage Vacuum Relays

Jennings vacuum relays are widely used in airborne, mobile and marine communications equipment. Typical applications include antenna coupling, tap changing on radio frequency (RF) coils, transmit / receive switching to an antenna, switching in pulse-forming networks and heavy duty power supplies. Our relays are noted for fast operating speeds and the ability to withstand high voltages and carry heavy currents (at frequencies up to 75 MHz), while maintaining low and stable contact resistance.

Vacuum relays are available in SPST normally open (N/O) and normally closed (N/C) models, as well as SPDT configurations. Latching relays are available in some models.

Vacuum as a Dielectric

Vacuum is the ideal dielectric for high voltage relay switching. It has extremely high voltage breakdown characteristics, a fast recovery rate (up to 10 kV per millisecond) and it provides an absolutely inert and non-reactive environment for switching contacts. Since there is no oxygen in a vacuum, contacts remain oxidation free.

The high dielectric strength of the vacuum permits close contact spacing, on the order of 1000 volts per mil (= 0.0394 inches). The small movement required to operate a vacuum relay permits the use of small, low mass actuators, allowing high operating speeds. Use of refractory metal contacts provides exceptional interrupting ability and ensures long contact life.

If a load is switched, an arc will be formed. At the point where the contacts are getting very close and the current density is getting higher and higher, a breakdown occurs. This arc will have a very low voltage of 18–23 V and be quite stable in comparison to an arc in air, which is another advantage of vacuum (Figure 1). The combination of constant arc voltage acting as a current limiter and short arc time means vacuum relays generally wear less than other types and give stable performance over the life of the relay.

Pressurized Gas as a Dielectric

(at Jennings, a mixture containing primarily SF-6)

Pure high pressure gas allows relays to attain high dielectric strength and to avoid oxidation. This dielectric is ideal for the high in-rush capacitive make and capacitive discharge loads. Typical applications include electrostatic discharge (ESD) test equipment, cable test equipment and heart defibrillators. Gas-filled relays also provide low, stable leakage current in applications sensitive to current fluctuations, especially across open contact sets over long periods of time.

Gas-filled relays, however, should not be used when it is necessary to break a current. As the contacts open, the gas is ionizing and an arc is formed and sustained for much longer than in vacuum.

The contact resistance of Jennings' gas-filled relays is typically measured at 28 V and will be higher than and not as stable as in a vacuum relay.

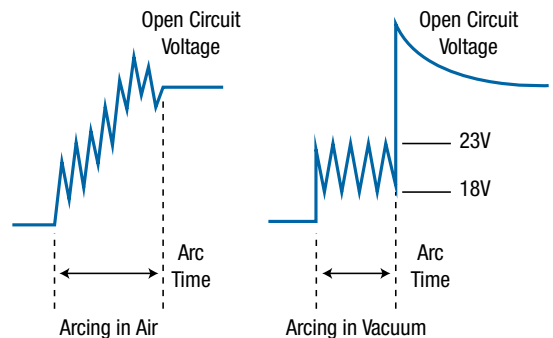

Figure 1



Typical Applications

RF Applications

Jennings vacuum relays play a vital role when high power and low RF losses are required.

- Vapor deposition for semiconductor wafer processing
- Transmitter/receiver switches
- Pulse forming networks
- Ion implant
- MRI power supplies
- Radar systems
- Security screening systems
- TWT power supplies
- Radio antenna tuning matching circuits

Test Equipment and Instrumentation

Jennings gas-filled relays are great for high in-rush and stable leakage current applications, and Jennings vacuum relays are the ideal solution for low leakage and high carry current applications.

- ESD pulse forming equipment
- HiPot testing
- Cable testing
- Motor winding testing
- Mega-ohm testing
- High power lasers
- Power supply testing
- Mass spectrometry
- High voltage power supplies
- Transformer test equipment
- Ballast test equipment

Specialized Applications

Jennings vacuum and gas-filled relays are excellent for:

- Airport lighting systems
- Geosciences down-hole data acquisition
- Scientific instrumentation
- Under-sea power distribution
- Sinusoidal heart defibrillators

Custom Applications

Because Jennings relays and contactors are sealed to support a vacuum, they can also be filled with special gases for custom applications. They can be re-packaged, tailored or tested to specific requirements.

- Super-low nano amperage leakage
- Screw terminals, long flying leads or special connectors
- Special packaging to replace obsolete relays
- Very low temperature applications
- High pressure oceanic applications
- Low out-gassing and Hi-Rel testing with traceability and configuration controls for space and satellites.

Basic Functionality – How Do Jennings Relays Work?

Jennings manufactures two common relay types:

1. Clapper type relay (Figure 2)
2. Diaphragm relay (Figure 3)

The pictures below shows both types and their main features.



Figure 2



Figure 3

A Jennings Vacuum Relay primarily consists of two main assemblies. We have the ceramic “switch” assembly, which contains the HV contacts, and the actuator assembly, which holds the actuation coil.

The two types differ in regards to the mechanical actuation. In the diaphragm relay, the actuator is placed outside of the vacuum envelope, whereas in the clapper type relay, we find the actuator inside the vacuum.

The assembly containing the coil is the driving part of the relay and will be connected to your driver circuit. As voltage is applied to the coil, a magnetic field is built up and an electro-magnetic force is created. This force is used to move the mechanism and thus the movable contact inside the vacuum envelope. The contact transfers from the N/C to the N/O position or, in a SPST relay, opens your high voltage circuit.

Basic Relay Terms and Definitions

Arc — An electric discharge between mating relay contacts when an energized circuit is interrupted.

Contact bounce — The intermittent undesirable opening of closed contacts or closing of open contacts.

Break — The opening of closed contacts to interrupt an electrical circuit.

Voltage breakdown — An undesirable condition of arcing within a relay due to overvoltage.

Cold — An unenergized electrical circuit.

Dielectric — An insulating medium capable of recovering, as electric energy, all or part of the energy required to establish an electrical field (voltage stress). The field, or voltage stress, is accompanied by displacement or charging currents. Vacuum is one of the best dielectrics.

Hot — An energized electrical circuit.

Make — The closure of open contacts to complete an electrical circuit.

Peak test voltage — The peak AC voltage (at 60 Hz) that can be applied between external high voltage terminals, or between an open terminal and ground, for up to one minute with no evidence of failure. Peak test voltages must not be exceeded, even for very short pulses.

Rated operating voltage (kV Peak) — The voltage that can safely be applied to the relay for sustained periods of time without failure. This voltage rating decreases as AC frequency increases. Rated operating voltages approach peak test voltage only at lower frequencies.

Continuous current, carry — The current that flows through the closed relay contacts for sustained time periods. This current rating is determined by the relay envelope temperature rise. A ceramic relay is allowed a 100°C rise. Current ratings can be increased by external cooling, such as forced air or heat sinks.

Contact capacitance — The capacitance of the relay measured (a) between open contacts or (b) between contact and ground. Measured at 1 kHz.

Contact resistance — The resistance between closed contacts, measured at 6.0 VDC with a 1.0 amp root mean square (RMS) load.

Operate time — The time in milliseconds between voltage being first applied to the relay coil and final closure of all normally open contacts. This time includes contact bounce.

Release time — The time in milliseconds between removal of power from the relay coil and final closing of all normally closed contacts. This time includes contact bounce.

Ambient temperature range — The range of environmental temperatures in which the relay mounted in the equipment will operate safely. Heat will be generated by the current flowing through the relay, which will elevate the temperature above ambient depending on the current level imposed.

Pull-in voltage — The minimum coil voltage required to operate a relay so that all normally open contacts close.

Dropout voltage — The maximum coil voltage at which an operating relay releases and all normally closed contacts close.

Coil resistance — The DC resistance, in ohms, of the coil — measured at 25°C.

Shock — The number of g's (gravities) a relay can sustain when tested by a sine pulse (calibrated impact) for 11 milliseconds without the closed contacts opening or the open contacts closing.

Vibration Peak — The maximum harmonic motion at rated gravities and frequencies that a relay can sustain without uncontrolled opening of closed contacts or closing of open contacts.

Expected mechanical life — The number of operations for which a relay can be expected to operate reliably. Cold switching applications approach this figure.

Contact arrangement: Jennings relays have the following contact arrangement:

- Single pole single throw (SPST)
- Single pole double throw (SPDT)

Contact form: The code for the relay model (see following page for more information):

- Form A: SPST—Normally Open
- Form B: SPST—Normally Closed
- Form C: SPDT
- Form Latching: SPST
- Form Latching: SPDT

Selection Guide

How to Use this Table

From the diagrams at the top of the table, choose the contact configuration that meets your requirements. Then choose from the list in that column the relay that meets your voltage and current specifications. Please refer to the product information included in this catalog and look for more detailed information on the selected relay.

You can use this table for all continuous current carry applications. For all power switching applications, please refer to the next section.

All relays in bold letters are generally ok to be hot switched.

Form A	Form B	Form C	Latching	Latching
SPST-N/O	SPST-N/C	SPDT	SPST	SPDT
RF42-26S, 4kV, 12A RF6A-26S, 10kV, 12A RF80-26S, 10kV, 35A RF51-26S, 12kV, 12A RF53-26S, 17.5kV, 15A RJ8A-26S, 33kV, 110A	RF41-26S, 4kV, 12A RF5A-26S, 10kV, 12A RF4A-26S, 10kV, 30A RF88-26S, 10kV, 35A RF50-26S, 12kV, 12A RF52-26S, 17.5kV, 15A RF69-26S, 24kV, 15A RGH3-24D2524, 70kV, 15A	RF1E-26S, 4kV, 8A RJ1H-26S, 5kV, 3A RJ1H-26N877, 5kV, 3A RJ1C-26S, 6kV, 18A RJ1D-15S, 7kV, 18A RF61-26S, 4kV, 10A RJ1A-26S, 5kV, 18A RF62-26S, 9kV, 10A RF65-12S, 9kV, 10A RJ1A-26N969, 10kV, 30A RF3A-26S, 10kV, 30A RJ2B-26S, 15kV, 50A RJ6B-26S, 15kV, 50A RJ6B-D3136, 15kV, 50A RJ4B-26S, 18kV, 50A RJ4C-26S, 18kV, 50A RF10B-26S, 20kV, 75A RJ9B-26S, 20kV, 110A RJ5B-26S, 30kV, 10A RGH5-26S, 50kV, 10A	RF44-26S, 6kV, 12A RF43-26S, 9kV, 12A RF47-26S, 10kV, 35A RF72-26S, 10kV, 50A RF73-26S, 14kV, 35A	RF60-26S, 4kV, 12A RF63-26S, 9kV, 10A

If you have more questions and would like to talk to someone about your specific application, please contact our technical sales department at 408-282-0363 or at jenningsales@tnb.com.



Non-Power Switching Applications

For applications where the circuit is switched with no load across the relay terminals (non-power switching), a relay performs either as an insulator or a conductor.

In the make mode, the contacts conduct the full current of the load, and contact current handling capacity is limited by heating caused by contact resistance. Special low resistance copper alloys are used for most cold switching relays to assure high current handling capabilities.

In the break mode, the relay must perform as a high voltage insulator. Stand-off voltages are highest at DC and low AC frequencies and decline at higher frequencies due to RF heating of the insulator. Ceramic insulators provide the best withstand capabilities for high RF applications.

RF Applications (at Jennings, typically 2–32 MHz)

Switching RF equipment hot can cause damage to various circuit elements, so RF circuits generally are switched cold. This means the power is completely removed at the time of switching, and the relay never breaks or makes the load.

The primary reasons for using vacuum relays in RF applications are their exceptional insulating qualities and their low RF contact resistance — as low as .03 ohms at 30 MHz. This low RF resistance remains stable throughout the service life of the relay because of the advantages provided by the vacuum environment.

Vacuum relays show a frequency-dependent current and voltage limitation. As frequency increases, the conduction path through the contacts decreases, causing contact surface heating and limiting the maximum RF voltage that can be withstood. Most of our relays have been rated at 2.5 MHz, 16 MHz and 32 MHz.

When a vacuum relay is open, RF voltage is seen across the open contacts or the contacts to ground. The relay in effect behaves as a high voltage capacitor measuring 1–2 pF. Current leakage through the insulator causes heating, which further establishes limits to maximum current ratings.

Figure 4 shows a typical transmitter application for an RJ6B Vacuum Relay. This relay has a set of low voltage sequence contacts as well as high voltage contacts. The high voltage contacts complete the circuit to the antenna before the transmitter is turned on and will delay switching the antenna until power is turned off. This ensures the transmitter is properly loaded when power is applied.

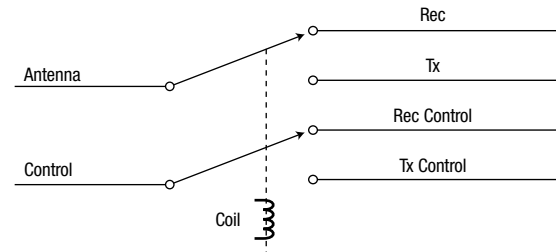

Figure 4 — RJ6B Relay Used as TR Relay and Switching Control

Pulse Applications

Vacuum relays are especially well suited in radar applications for pulse forming networks with pulse lengths from 1 ms to 10 ms (Figure 5). These applications require a relay to withstand the pulse forming network voltage on a repetitive basis, usually from 100 to 500 pulses per second. Higher peak currents can be used in this type of service due to the low duty cycle and short pulse duration. Average energy dissipated in the relay is low, heating minimal, and consequently voltages up to peak ratings and peak currents to 1000 amps can be utilized.

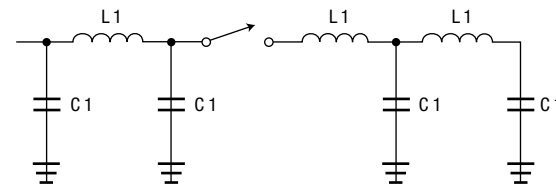

Figure 5 — Pulse Forming Network Typical Duty Cycle — 001

Please contact our technical department to help you determine which relay fits your pulse application.

Power Switching Applications

Direct Power Switching — Make and Break

AC circuits are inherently much easier to switch at high current levels than DC circuits. Current zeroes occur twice per AC cycle, and the high recovery voltage of the vacuum dielectric ensures extinction at the first current zero, reducing arcing and subsequent contact erosion.

The refractory metals used for contacts in relays intended for hot DC switching are selected to withstand arcing by their high melting temperatures and hardness. Vacuum relays have higher switching capabilities than most relays, but above 1 kV, they are generally limited to a maximum of 15 amps. When higher current levels are to be switched, suppression or bucking circuits (Figure 6) should be used to develop artificial current zeroes. This circuit keeps contact differential voltage at a minimum until the contacts fully open.

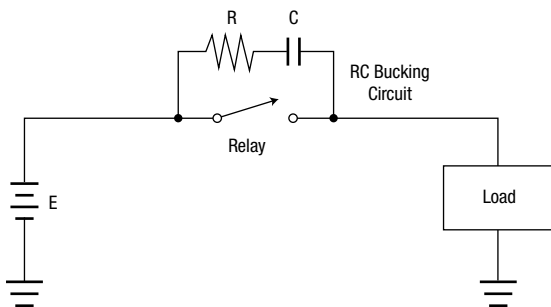

Figure 6

Do not use gas-filled relays for make-and-break power switching, because the relay will draw an arc on opening and sustain the arc. Thus, the relay will not be able to reliably open the contacts.

There are some other considerations when looking at using a vacuum or gas-filled relay in your power switching application.

Which elements dominate the electrical circuit?

Circuit loads can generally be considered as resistive, capacitive or inductive, even though they may consist of both active (tubes and solid-state devices) and passive elements (capacitors, resistors, inductors, etc.). Circuits with significant capacitive or inductive elements are more difficult to switch due to the stored energy. Figures 7A, 7B and 7C show the current for each type of load.

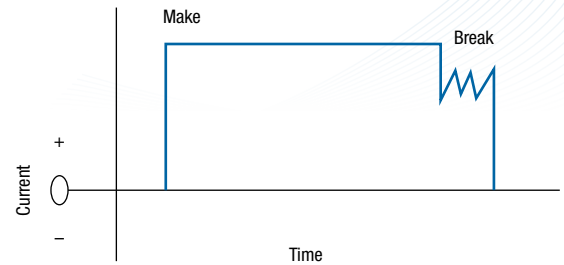

Figure 7A — Resistive Load Profile

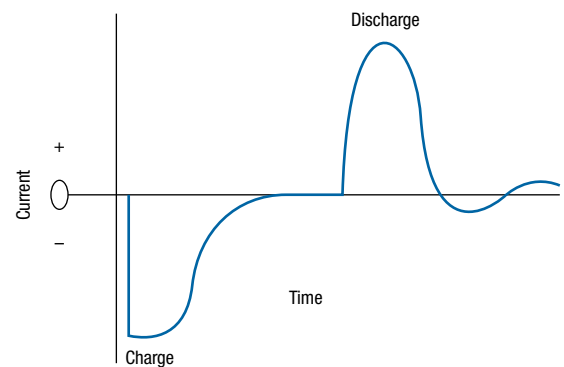

Figure 7B — Capacitive Load Profile

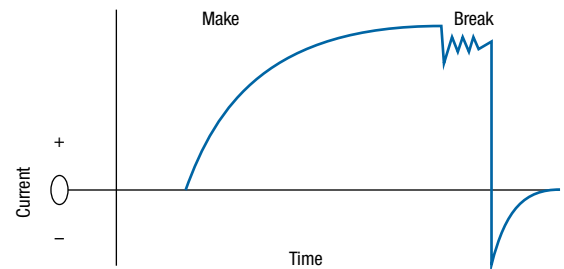

Figure 7C — Inductive Load Profile

Circuits made up primarily of resistive components have little effect upon voltage across HV terminals (Figure 7A). Resistive loads are generally used to generate the power switch rating of a vacuum relay.

When circuits with large capacitive elements break, a negative bias voltage appears equal to the stored energy of the capacitor. This stored energy can cause a momentary high current surge upon make (Figure 7B). As the contacts close, an arc is generated, and there is the danger of contact welding due to that short high energy spike.

With inductive elements present, a high momentary voltage transient occurs when the circuit is broken, which decays rapidly to open line voltage (Figure 7C). This spike can damage any other circuit elements, and we recommend that you clamp the voltage sufficiently in order to protect your circuit.

Is a ground-isolated relay available? Or can the relay be positioned on the ground side of the load?

Jennings has a number of relays available with ground isolation from the vacuum enclosures. Typical types are RF1, RF3, RF4 and RF10, as well as all RF40, 50, 60 and 70 series relays. Ground-isolated relays can be used within their voltage ratings without concern for ground faults, because the switching part of the relay is completely isolated from ground.

If only relays with internal grounds are available for your hot switch application, the relay should always be placed on the ground side of the load to prevent breakdown damage. Otherwise, fault conditions may cause internal arc-over to the grounded housing (Figure 8).

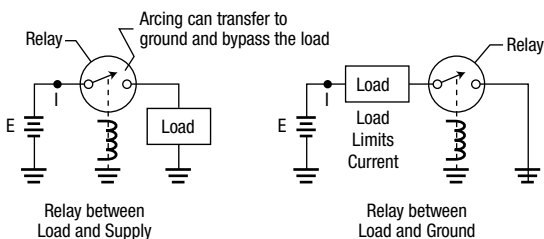

Figure 8

Capacitive Discharge or Make-Only Switching

Gas-filled relays are ideal for the high in-rush capacitive make and capacitive discharge loads found in electrostatic discharge (ESD) test equipment, cable test equipment and heart defibrillators. Typical models are the RGH5-26S or the RGH3-26S.

Gas-filled relays also provide low, stable leakage current in applications sensitive to current fluctuations, especially across open contact sets over long periods of time. However, these relays should not be used when it is necessary to break a current. As the contacts open, the gas will ionize, and an arc will be formed and sustained for much longer than in vacuum.

Vacuum relays are also often used in high voltage circuits to protect personnel by shorting out (bleeding) a capacitive circuit to ground once the high voltage has been removed. The low resistance contacts of a vacuum relay allow very high peak currents to be handled (up to 200 amps for up to 50 milliseconds without contact deterioration or welding). Arc contact welding is a function of arc voltage (a constant 18–23 volts), current and time. Currents of up to 500 amps have been carried for 10 milliseconds without failure.

Most standard relays will handle discharge pulses of 200 joules. In most applications, a series load resistor is used to lengthen capacitor discharge time to reduce peak current carried by the relay (Figure 9).

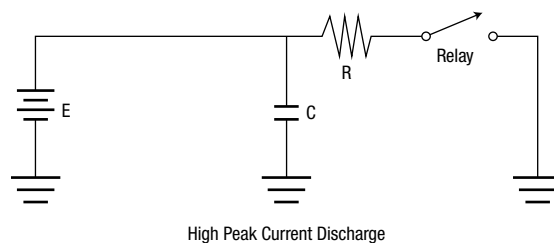

Figure 9

The Relay Driver Circuit

Relay Timing Characteristics

The coil voltage greatly affects relay operating speed, with higher voltages giving higher speeds. With a slightly higher than nominal voltage applied to the coil, the speed will immediately increase. It is important, though, to prevent overheating and be aware of the maximum allowable voltage for the relay that is used. For example, a 26.5 VDC coil should not exceed 32 VDC for continuous duty.

The preferable method is to use an overvoltage pulse that decays to normal operating potential in a few milliseconds (Figure 10). A simple RC network placed between the power supply and the relay will do this.

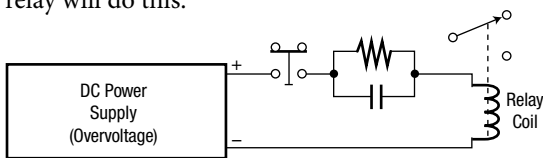

Figure 10

Transients in the Relay Driver Circuit

When the relay coil is turned on, the magnetic field takes a few moments to build up — at the same time energy is being stored in the coil. When the coil is later turned off, the stored energy can cause a voltage spike in the driver circuit and damage other components.

To increase the de-energized time and eliminate voltage transients, a zener-diode or zener-zener combination can be used across the coil (Figure 11). High voltage transients can be eliminated with an inductor/diode combination placed between the power supply and the relay (Figure 12).

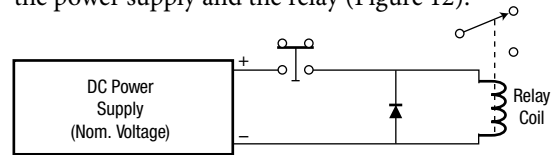

Figure 11

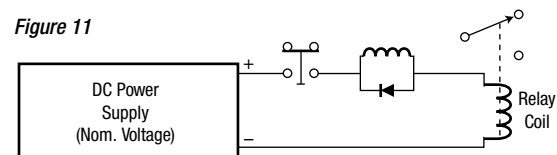

Figure 12

It is important to understand how the method chosen to suppress any transients will affect the relay operating characteristics.



Relay Mounting and Installation

- The relay envelope may become contaminated during transfer or assembly. Keep the envelope surface clean.
- Protect the relay from physical damage while storing and while mounting.
- When soldering wires onto the relay terminals, always make sure to remove excess flux as well as to clean the ceramic surface in order to ensure proper isolation. Please see our website for soldering guidelines for the some common relay types.
- When vacuum relays are mounted, the relay base should be connected to ground (also see Figure 8 on page 10 for more information on positioning of the relay within the circuit).
- The mounting methods shown are a few of the most common methods used by Jennings customers. In addition, Jennings offers a variety of flanges to further meet your needs. Should your application require mounting other than what is shown, we will be happy to discuss alternative methods. (NOTE: All models may be mounted and operated in any position.)
- When mounting relays that are to be used at RF frequency, copper straps are often soldered onto the HV terminals for better heat transfer and cooling.
- Please contact us for additional information on adapters for coil terminals, heat sinks or any other mounting questions.

Maintenance

Under normal operating conditions, relays do not need any maintenance. They should be kept free from dust and in a dry environment.

Safety Information

Vacuum relays may be used to switch high voltages at various frequencies. To avoid the danger of electrical shock, all circuits connected to the relay must be de-energized before connection, disconnection or testing.

WARNING

**DISCONNECT POWER BEFORE
SERVICING. HAZARDOUS
VOLTAGE CAN SHOCK, BURN
OR CAUSE DEATH.**

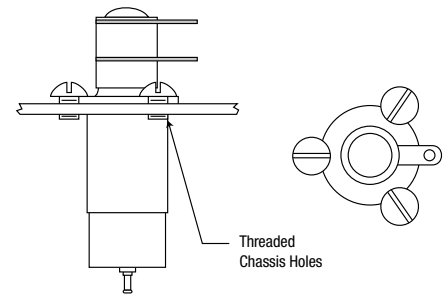

Figure 13A — Typical Screw Mounting

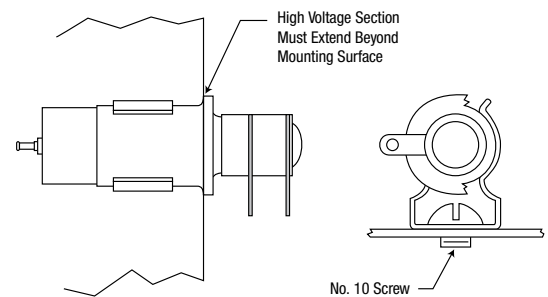

Figure 13B — Flange Mounting
(optional flanges are available on many relays)

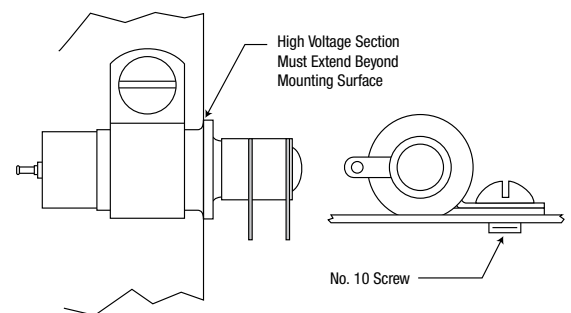

Figure 13C — Clamp Mounting

PRODUCT NUMBER	TEST VOLTAGE (kV PEAK) 60 Hz	RATED OPERATING VOLTAGE (kV PEAK)				12 VDC coil versions available; please contact factory for lead times. For available flange versions, the flange diameter is 1.125"											
		MAX CONT. CURRENT (Amps)				CONTACT CAPACITY (pF)		MAX CONTACT RESIST. (mΩ)	MAX OPERATE TIME (ms)	MAX RELEASE TIME (ms)	PULL-IN VOLTAGE @ 25°C (Vdc)	DROP-OUT VOLTAGE @ 25°C (Vdc)	COIL RESISTANCE (Ω ±10%)	SHOCK, 11ms ½ SINE (PEAK g's)	VIBRATION PEAK g's @ FREQ.	MECHANICAL LIFE (10 ⁶ CYCLES)	WEIGHT, oz. (grams)
		DC OR 60Hz	2.5 MHz	16 MHz	32 MHz	OPEN CONTACT TO OPEN CONTACT	OPEN CONTACTS TO GROUND										
RF41-26S RF42-26S	4	3.6	3.6	3.2	2.5	1.6	1.6	20	10	10	16	1-10	290	50	10 @ 55-2000 Hz	1	1 (28)
RF44-26S	6	3.6	3.6	3.2	2.5	1.6	1.6	12	4	4	16	1-10	80	50	30 @ 95-2000 Hz	1	1 (28)
RF43-26S	9	7	7	6	4	1.6	1.1	20	10	10	16	1-10	47	50	10 @ 55-500 Hz	0.5	1 (28)

RF41-26S

Form:
N/C

Flange Version Available:
RF41D-26S

RF42-26S

Form:
N/O

Flange Version Available:
RF42D-26S

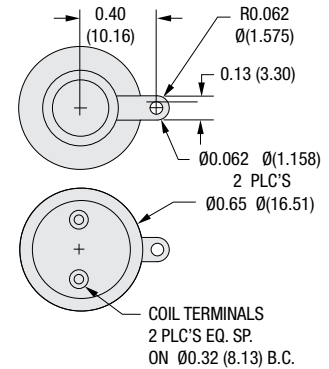
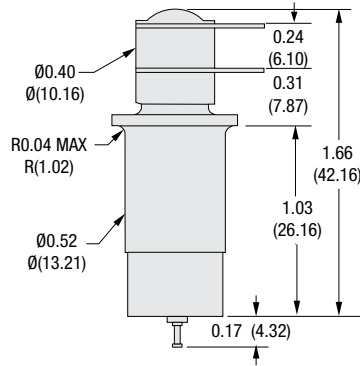

RF44-26S

Form:
Latching

Flange Version Available:
RF44D-26S

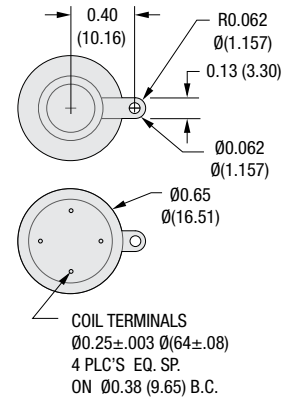
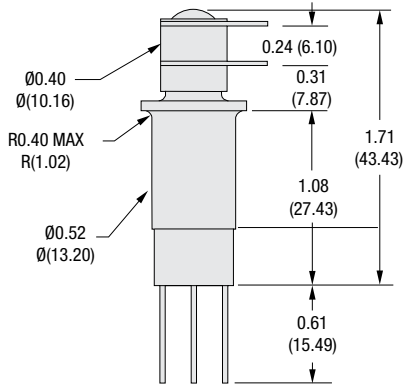

RF43-26S

Form:
Latching

Flange Version Available:
RF43D-26S

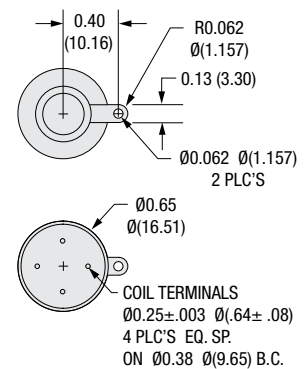
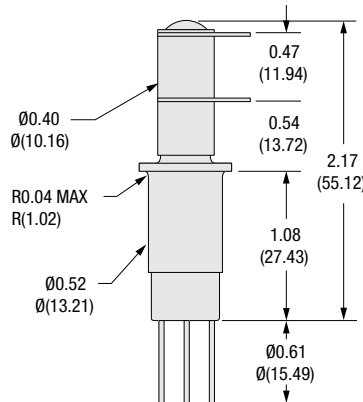

PRODUCT NUMBER	TEST VOLTAGE (kV PEAK) 60 Hz	RATED OPERATING VOLTAGE (kV PEAK)				12 VDC coil versions available; please contact factory for lead times. For available flange versions, the flange diameter is 1.125"												
		MAX CONT. CURRENT (Amps)				CONTACT CAPACITY (pF)		MAX CONTACT RESIST. (m Ω)	MAX OPERATE TIME (ms)	MAX RELEASE TIME (ms)	PULL-IN VOLTAGE @ 25°C (Vdc)	DROP-OUT VOLTAGE @ 25°C (Vdc)	COIL RESISTANCE ($\Omega \pm 10\%$)	SHOCK, 11ms 1/2 SINE (PEAK g's)	VIBRATION PEAK g's @ FREQ.	MECHANICAL LIFE (10 ⁶ CYCLES)	WEIGHT, oz. (grams)	
		DC OR 60Hz	2.5 MHz	16 MHz	32 MHz	OPEN CONTACT TO OPEN CONTACT	OPEN CONTACTS TO GROUND											
RF4A-26S	10	8	7	6	5	2.5	2.5	15	18	18	16	1-10	156	50	10 @ 55-2000 Hz	1	2 (56)	
		30	25	15	10													
RF5A-26S RF6A-26S	10	8	8	6	5	1.6	1.6	20	8	6	16	1-10	920	30	10 @ 55-1000 Hz	10	.5 (14)	
		12	10	5	2													
RF47-26S	10	8	8	6	5	1.6	1.6	8*	4	4	16	1-10	80	50	30 @ 55-2000 Hz	1	1 (28)	
		35	35	18	12													

RF4A-26S

Form: N/C
Equipped with integral flange

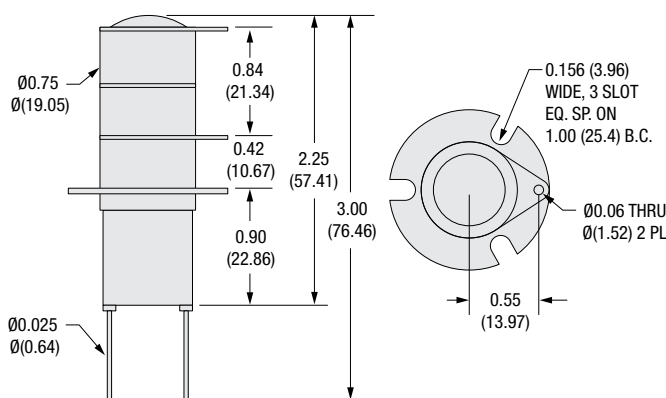

RF5A-26S

Form: N/C
Flange Version Available: RF5AD-26S

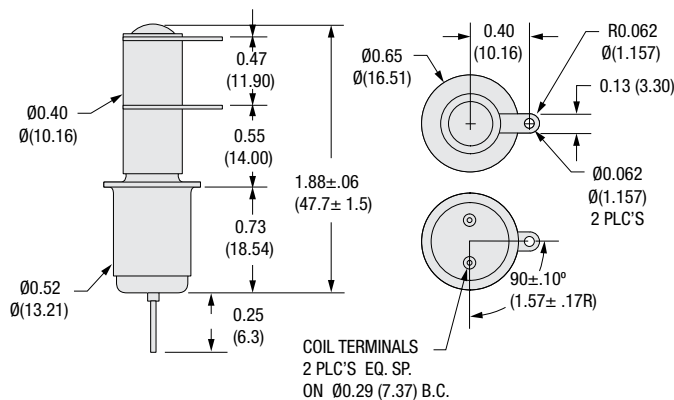

RF6A-26S

Form: N/O
Flange Version Available: RF6AD-26S

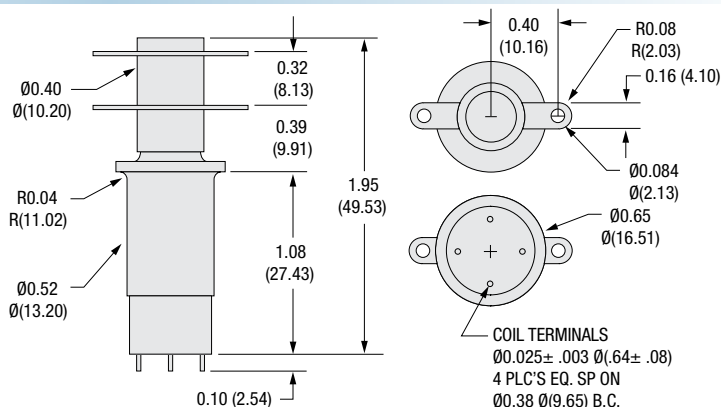

RF47-26S

Form: Latching
Flange Version Available: RF47D-26S

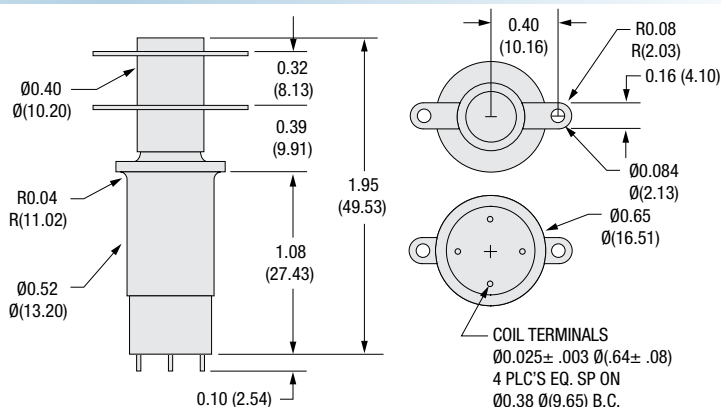

* Please contact Jennings Technology for lower/different values.

PRODUCT NUMBER	TEST VOLTAGE (kV PEAK) 60 Hz	RATED OPERATING VOLTAGE (kV PEAK)				12 VDC coil versions available; please contact factory for lead times. For available flange versions, the flange diameter is 1.125"											
		MAX CONT.CURRENT (Amps)				CONTACT CAPACITY (pF)		MAX CONTACT RESIST. (mΩ)	MAX OPERATE TIME (ms)	MAX RELEASE TIME (ms)	PULL-IN VOLTAGE @ 25°C (Vdc)	DROP-OUT VOLTAGE @ 25°C (Vdc)	COIL RESISTANCE (Ω ±10%)	SHOCK, 11ms ½ SINE (PEAK g's)	VIBRATION PEAK g's @ FREQ.	MECHANICAL LIFE (10 ⁶ CYCLES)	WEIGHT, oz. (grams)
		DC OR 60Hz	2.5 MHz	16 MHz	32 MHz	OPEN CONTACT TO OPEN CONTACT	OPEN CONTACTS TO GROUND										
RF72-26S RF72-N1105 RF72-N1107	10	8	8	6	5	1.6	1.6	20	4	4	16*	1-10*	80	50	30 @ 55-2000 Hz	2	1 (28)
RF80-26S	10	8	8	6	4	1.6	1.6	8*	8	3	16	1-10	290	30	10 @ 55-2000 Hz	2	1 (28)
RF88-26S	10	8	8	6	5	1.6	1.6	20	4	4	16	1-10	80	50	10 @ 55-2000 Hz	1	1 (28)

RF72-26S RF72-N1105 RF72-N1107

All three models —

Form:
Latching

Flange Version Available:
Yes, please call to order

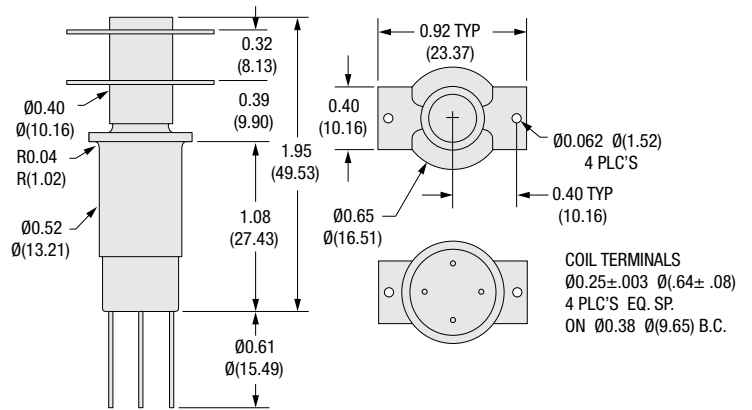

RF80-26S

Form:
N/O

Flange Version Available:
Yes, please call to order

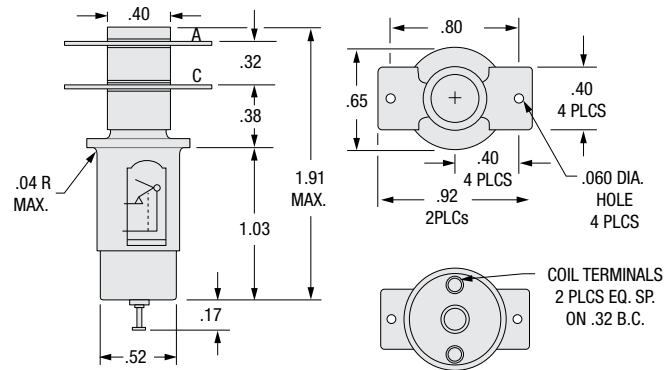

RF88-26S

Form:
N/C

Flange Version Available:
Yes, please call to order

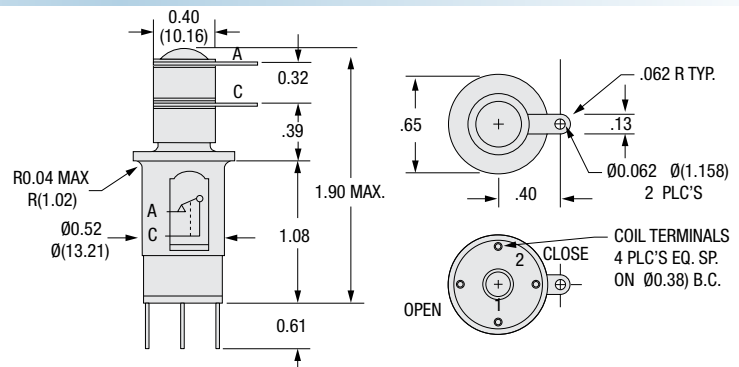

* Please contact Jennings Technology for lower/different values.

PRODUCT NUMBER	TEST VOLTAGE (kV PEAK) 60 Hz	RATED OPERATING VOLTAGE (kV PEAK)				12 VDC coil versions available; please contact factory for lead times. For available flange versions, the flange diameter is 1.125"												
		MAX CONT. CURRENT (Amps)				CONTACT CAPACITY (pF)		MAX CONTACT RESIST. (mΩ)	MAX OPERATE TIME (ms)	MAX RELEASE TIME (ms)	PULL-IN VOLTAGE @ 25°C (Vdc)	DROP-OUT VOLTAGE @ 25°C (Vdc)	COIL RESISTANCE (Ω ±10%)	SHOCK, 11ms ½ SINE (PEAK g's)	VIBRATION PEAK g's @ FREQ.	MECHANICAL LIFE (10 ⁶ CYCLES)	WEIGHT, oz. (grams)	
		DC OR 60Hz	2.5 MHz	16 MHz	32 MHz	OPEN CONTACT TO OPEN CONTACT	OPEN CONTACTS TO GROUND											
RF50-26S† RF51-26S†	12*	10	7	6	4	1.5	1.5	20	15	15	16	1-10	290	50	10 @ 55-2000 Hz	0.5	1 (28)	
RF73-26S	14	12	12	9	7	1.2	1.2	8**	4	4	16*	1-10*	47	30	10 @ 55-2000 Hz	5	1.5 (43)	
RF52-26S RF53-26S	17.5	12	12	9	7	0.8	0.8	20	15	15	16	1-10	290	30	10 @ 55-500 Hz	1	1 (28)	

RF50-26S†

Form: N/C
Flange Version Available: RF50D-26S

RF51-26S†

Form: N/O
Flange Version Available: RF51D-26S

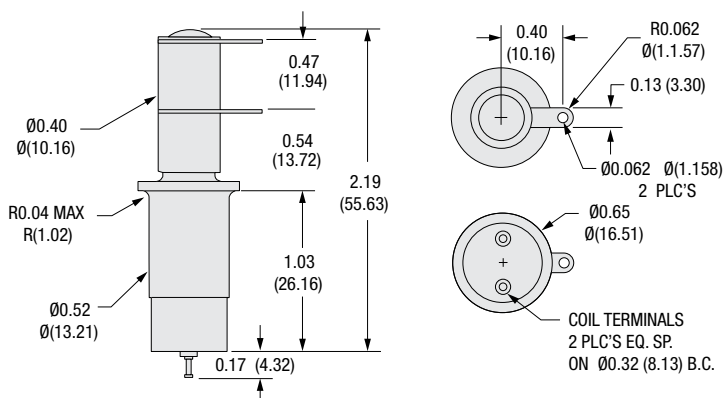

RF73-26S

Form: Latching
Flange Version Available: Yes, please call to order

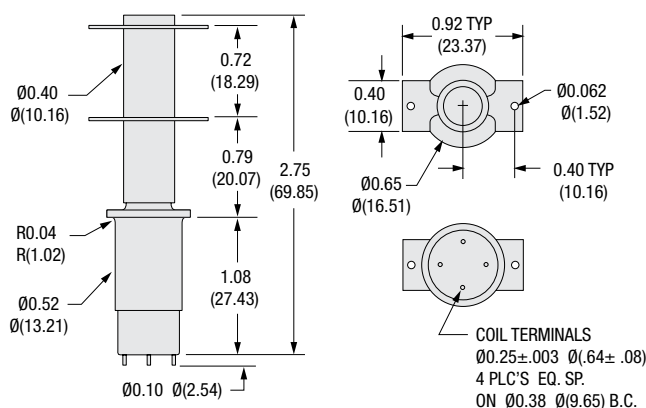

RF52-26S

Form: N/C
Flange Version Available: RF52D-26S

RF53-26S

Form: N/O
Flange Version Available: RF53D-26S

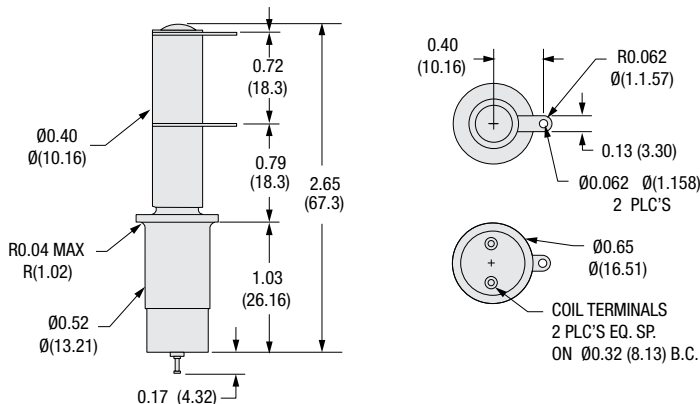

† Can be used for hot switch applications.

* 2 kV achieved in insulating medium: fluorocarbon liquid or tightly adherent and void-free encapsulant.

** Please contact Jennings Technology for lower different values.

PRODUCT NUMBER	TEST VOLTAGE (kV PEAK) 60 Hz	RATED OPERATING VOLTAGE (kV PEAK)				12 VDC coil version available for model RF69-26S; please contact factory for lead times. For available flange versions, the flange diameter is 1.125"											
		MAX CONT. CURRENT (Amps)				CONTACT CAPACITY (pF)		MAX CONTACT RESIST. (mΩ)	MAX OPERATE TIME (ms)	MAX RELEASE TIME (ms)	PULL-IN VOLTAGE @ 25°C (Vdc)	DROP-OUT VOLTAGE @ 25°C (Vdc)	COIL RESISTANCE (Ω ±10%)	SHOCK, 11ms ½ SINE (PEAK g's)	VIBRATION PEAK g's @ FREQ.	MECHANICAL LIFE (10 ⁶ CYCLES)	WEIGHT, oz. (grams)
		DC OR 60Hz	2.5 MHz	16 MHz	32 MHz	OPEN CONTACT TO OPEN CONTACT	OPEN CONTACTS TO GROUND										
RF69-26S	24	12	—	—	—	2.5	2.5	40	15	15	18	1-10	290	30	.06 @ 55-500 Hz	2	3 (85)
		15	—	—	—												
RJ8A-26S	33	28	25	12	10	1.3	1	3	18	8	16	1-10	120	30	10 @ 55-500 Hz, 5 @ 500-2000 Hz	2	10 (283)
		110	60	40	30												

RF69-26S

Form:
N/C

Equipped with integral flange

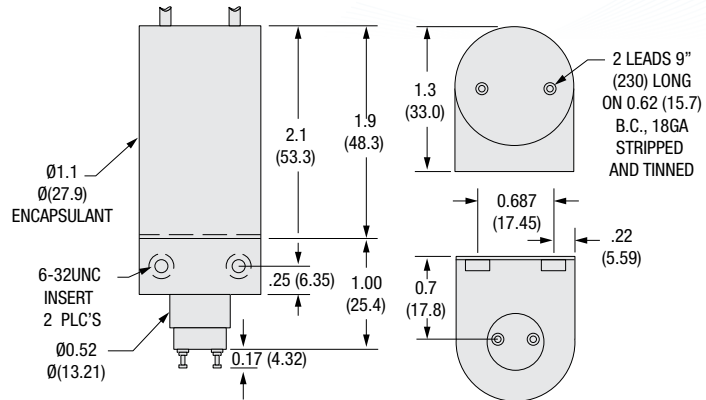

RJ8A-26S

Form:
N/O

Flange Version Available:
None

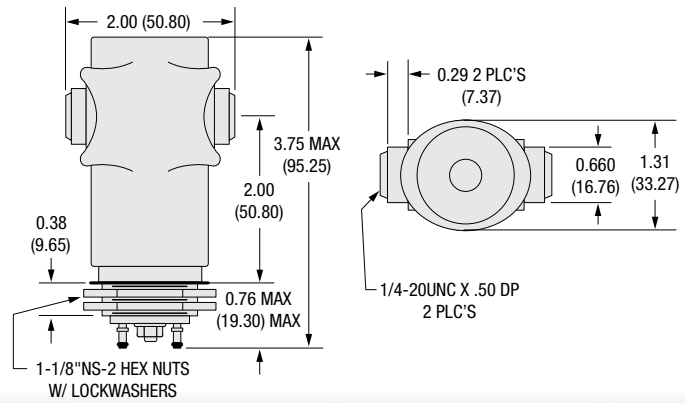

PRODUCT NUMBER	TEST VOLTAGE (kV PEAK) 60 Hz	RATED OPERATING VOLTAGE (kV PEAK)				12 VDC coil versions available; please contact factory for lead times. For available flange versions, the flange diameter is 1.125"											
		MAX CONT. CURRENT (Amps)				CONTACT CAPACITY (pF)		MAX CONTACT RESIST. (mΩ)	MAX OPERATE TIME (ms)	MAX RELEASE TIME (ms)	PULL-IN VOLTAGE @ 25°C (Vdc)	DROP-OUT VOLTAGE @ 25°C (Vdc)	COIL RESISTANCE (Ω ±10%)	SHOCK, 11ms ½ SINE (PEAK g's)	VIBRATION PEAK g's @ FREQ.	MECHANICAL LIFE (10 ⁶ CYCLES)	WEIGHT, oz. (grams)
		DC OR 60Hz	2.5 MHz	16 MHz	32 MHz	OPEN CONTACT TO OPEN CONTACT	OPEN CONTACTS TO GROUND										
RF1E-26S	4	2	2	2	2	1.6	2	30	10	10	16	1-10	920	30	10 @ 55-2000 Hz	10	1 (28)
		8	6	4	2												
RF60-26S	4	3.6	3.6	3.2	2.5	1.6	1.6	20	7	7	18	1-12	47	50	10 @ 55-2000 Hz	0.5	1 (28)
		12	10	6	5												
RF61-26S	4	3.6	3.6	3.2	2.5	1.6	1.6	20	10	10	16	1-10	290	50	10 @ 55-2000 Hz	0.5	1 (28)
		10	8	7	5												

RF1E-26S

Form: SPDT

Flange Version Available: RF1D-26S

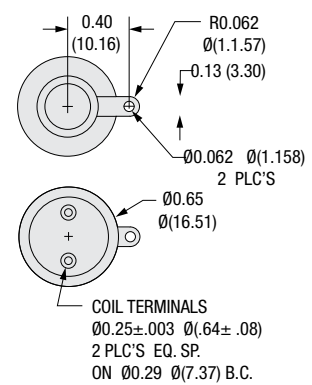
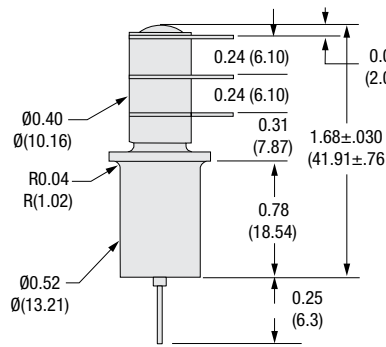

RF60-26S

Form: Latching

Flange Version Available: RF60D-26S

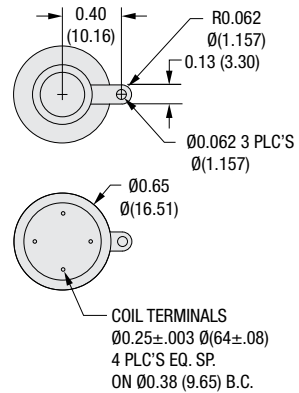
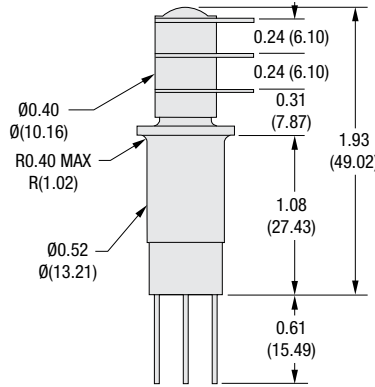

RF61-26S

Form: SPDT

Flange Version Available: RF61D-26S

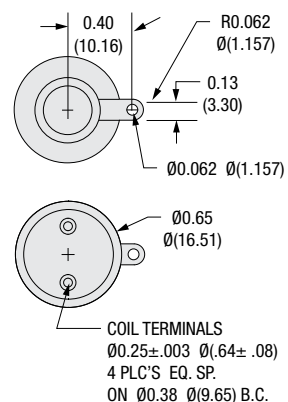
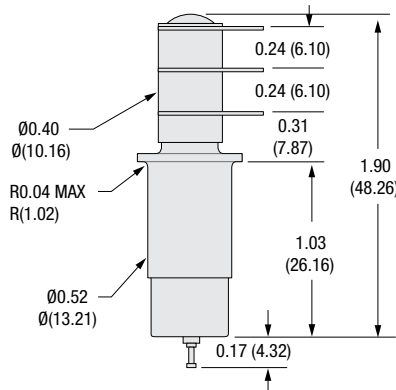

PRODUCT NUMBER	TEST VOLTAGE (kV PEAK) 60 Hz	RATED OPERATING VOLTAGE (kV PEAK)				12 or 115 VDC coil versions available; please contact factory for lead times. For available flange versions, the flange diameter is 1.125"												
		MAX CONT.CURRENT (Amps)				CONTACT CAPACITY (pF)		MAX CONTACT RESIST. (mΩ)	MAX OPERATE TIME (ms)	MAX RELEASE TIME (ms)	PULL-IN VOLTAGE @ 25°C (Vdc)	DROP-OUT VOLTAGE @ 25°C (Vdc)	COIL RESISTANCE (Ω ±10%)	SHOCK, 11ms ½ SINE (PEAK g's)	VIBRATION PEAK g's @ FREQ.	MECHANICAL LIFE (10 ⁶ CYCLES)	WEIGHT, oz. (grams)	
		DC OR 60Hz	2.5 MHz	16 MHz	32 MHz	OPEN CONTACT TO OPEN CONTACT	OPEN CONTACTS TO GROUND											
RJ1A-26S	5	3.5	2.5	2	1.5	2	2.5	10	8	8	16	1-10	335	50	10 @ 55-2000 Hz	2	1 (28)	
		18	14	9	7													
RJ1H-26S [†] RJ1H-26N877 [†]	5	2.5	Hot Break	—		2	2.5	30	6	6	16	1-10	335	50	10 @ 55-2000 Hz	2	1 (28)	
		3	Hot Break	—														
RJ1C-26S ^{†*} RJ1D-15S ^{†*}	6	6	Hot Break	—		2	2.5	20	6	6	14	1-10	335	50	20 @ 35-60 Hz, 40 @ 60-125 Hz, 30 @ 125-550 Hz	1	1 (28)	
	7	7	Hot Break	—														18

RJ1A-26S

Form: SPDT
Flange Version Available: None

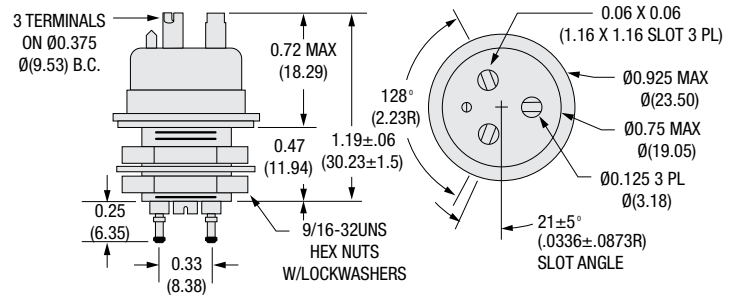

RJ1H-26S[†]

Form: SPDT
Flange Version Available: None

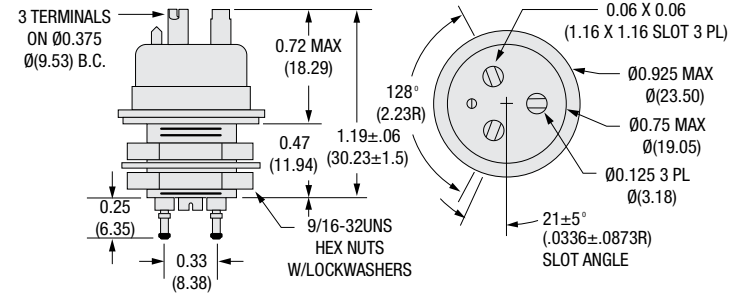

RJ1H-26N877[†]

Form: SPDT
Flange Version Available: None

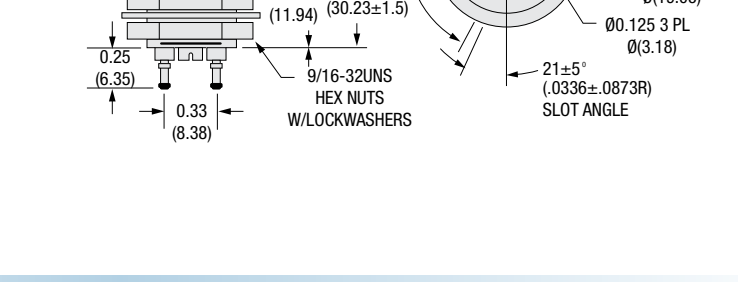

RJ1C-26S^{†*}

Form: SPDT
Flange Version Available: None

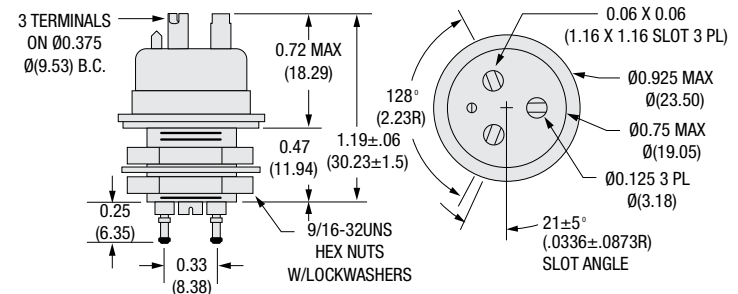

RJ1D-15S^{†*}

Form: SPDT
Flange Version Available: None

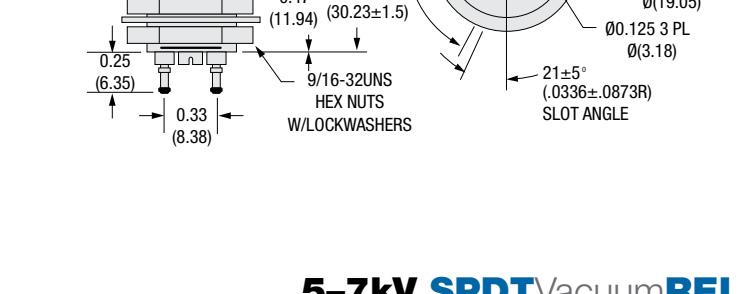

[†] Can be used for hot switch applications.

* Units to be encapsulated by customer, extended vibration profile, HiPot in insulating fluid.

PRODUCT NUMBER	TEST VOLTAGE (kV PEAK) 60 Hz	RATED OPERATING VOLTAGE (kV PEAK)				12 VDC coil versions available; please contact factory for lead times. For available flange versions, the flange diameter is 1.125"												
		MAX CONT. CURRENT (Amps)				CONTACT CAPACITY (pF)		MAX CONTACT RESIST. (m Ω)	MAX OPERATE TIME (ms)	MAX RELEASE TIME (ms)	PULL-IN VOLTAGE @ 25°C (Vdc)	DROP-OUT VOLTAGE @ 25°C (Vdc)	COIL RESISTANCE ($\Omega \pm 10\%$)	SHOCK, 11ms ½ SINE (PEAK g's)	VIBRATION PEAK g's @ FREQ.	MECHANICAL LIFE (10 ⁶ CYCLES)	WEIGHT, oz. (grams)	
		DC OR 60Hz	2.5 MHz	16 MHz	32 MHz	OPEN CONTACT TO OPEN CONTACT	OPEN CONTACTS TO GROUND											
RF62-26S	9	7	7	6	4	1.6	1.1	20	10	10	16	1-10	290	50	10 @ 55-2000 Hz	1	1 (28)	
RF65-12S		10	10	6	5													
RF63-26S	9	7	7	6	4	1.6	1.1	20	10	10	16	1-10	47	50	10 @ 55-2000 Hz	1	1 (28)	
		10	10	6	5													
RF3A-26S	10	8	7	6	5	4	2.5	15	18	18	16	1-10	156	50	10 @ 55-2000 Hz	1	2 (56)	
		30	25	15	10													

RF62-26S

Form: SPDT

Flange Version Available: RF62D-26S

RF65-12S

Form: SPDT

Flange Version Available: RF65D-12S

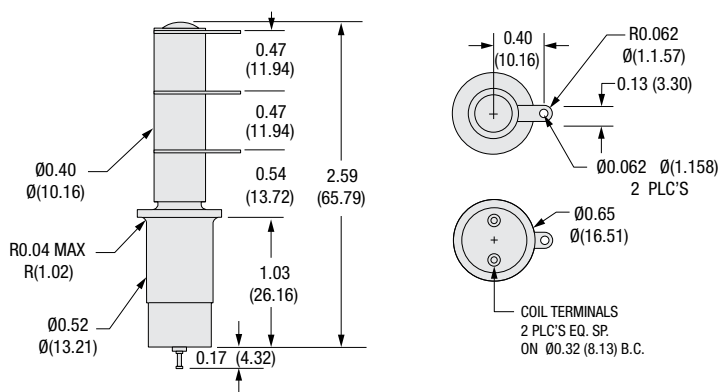

RF63-26S

Form: Latching

Flange Version Available: RF63D-26S

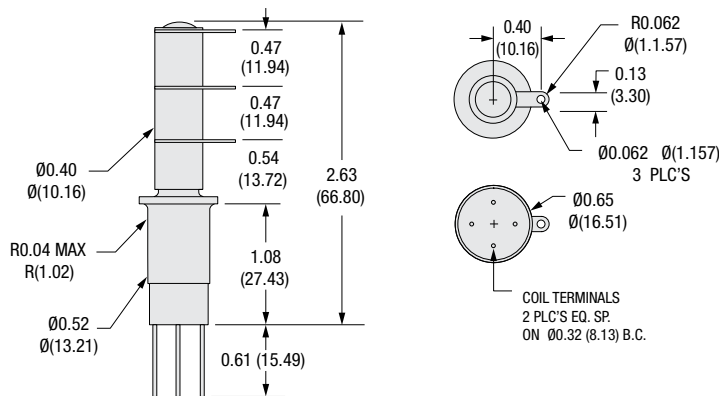

RF3A-26S

Form: SPDT

Equipped with integral flange

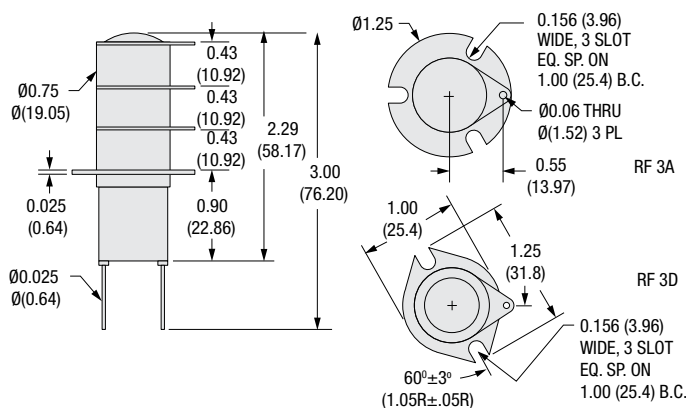

PRODUCT NUMBER	TEST VOLTAGE (kV PEAK) 60 Hz	RATED OPERATING VOLTAGE (kV PEAK)				12 or 115 VDC coil versions available; please contact factory for lead times. For available flange versions, the flange diameter is 1.125"											
		MAX CONT. CURRENT (Amps)				CONTACT CAPACITY (pF)		MAX CONTACT RESIST. (mΩ)	MAX OPERATE TIME (ms)	MAX RELEASE TIME (ms)	PULL-IN VOLTAGE @ 25°C (Vdc)	DROP-OUT VOLTAGE @ 25°C (Vdc)	COIL RESISTANCE (Ω ±10%)	SHOCK, 11ms ½ SINE (PEAK g's)	VIBRATION PEAK g's @ FREQ.	MECHANICAL LIFE (10 ⁶ CYCLES)	WEIGHT, oz. (grams)
		DC OR 60Hz	2.5 MHz	16 MHz	32 MHz	OPEN CONTACT TO OPEN CONTACT	OPEN CONTACTS TO GROUND										
RJ1A-26N696	10	8	—	—	—	2	2.5	10	8	8	16	1-10	335	50	10 @ 55-2000 Hz	2	1 (28)
		18	—	—	—												
RJ2B-26S [†] RJ6B-26S [†]	15	12	10	8	6	0.5 1	1 1.5	12	18	9	16	1-10	270	50	10 @ 55-500 Hz	1 25	3 (85)
		50	30	17	10												
RJ6B-D3136 [†]	15	12	10	8	6	1	1.5	12	18	9	16	1-10	270	50	10 @ 55-500 Hz	25	3 (85)
		50	30	17	10												

RJ1A-26N696

Form: SPDT
Flange Version Available: None

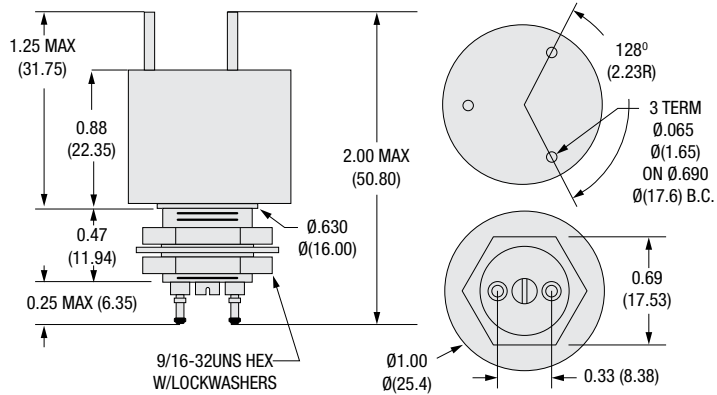

RJ2B-26S[†]

Form: SPDT
Flange Version Available: RJ2C-26S

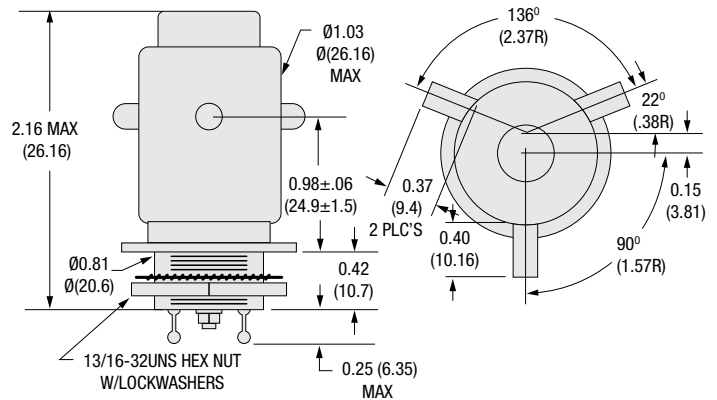

RJ6B-26S[†]

Form: SPDT
Flange Version Available: RJ6C-26S

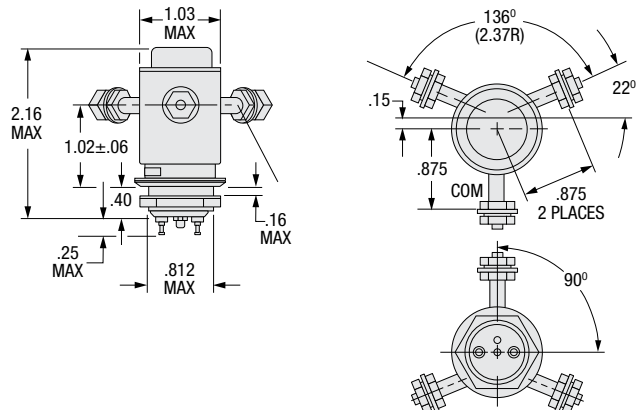

RJ6B-D3136[†]

Form: SPDT
Flange Version Available: RJ6C-26D3136

[†] Can be used for hot switch applications.

PRODUCT NUMBER	TEST VOLTAGE (kV PEAK) 60 Hz	RATED OPERATING VOLTAGE (kV PEAK)				CONTACT CAPACITY (pF)		12 or 115 VDC coil versions available for models RJ4B-26S and RJ4C-26S; please contact factory for lead times. For available flange versions, the flange diameter is 1.125"									
		MAX CONT. CURRENT (Amps)				OPEN CONTACT TO OPEN CONTACT	OPEN CONTACTS TO GROUND	MAX CONTACT RESIST. (m Ω)	MAX OPERATE TIME (ms)	MAX RELEASE TIME (ms)	PULL-IN VOLTAGE @ 25°C (Vdc)	DROP-OUT VOLTAGE @ 25°C (Vdc)	COIL RESISTANCE (Ω \pm 10%)	SHOCK, 11ms 1/2 SINE (PEAK g's)	VIBRATION PEAK g's @ FREQ.	MECHANICAL LIFE (10 ⁶ CYCLES)	WEIGHT, oz. (grams)
		DC OR 60Hz	2.5 MHz	16 MHz	32 MHz												
RJ4B-26S [†]	18	15	12	10	6	0.5	1	12	18	9	14	1-10	270	30	10 @ 55-500 Hz	1	3 (85)
		50	30	17.5	10												
RJ4C-26S [†]	18	15	12	10	6	0.5	1	12	18	9	14	1-10	270	30	10 @ 55-500 Hz	1	3 (85)
		50	30	17.5	10												
RF10B-26S	20	15	13	10	7.5	1.8	1.5	12	30	12	16	1-10	225	30	5 @ 55-500 Hz	0.1	16 (453)
		75	22	15	12												

RJ4B-26S[†]

Form: SPDT

Flange Version Available: RJ4C-26S

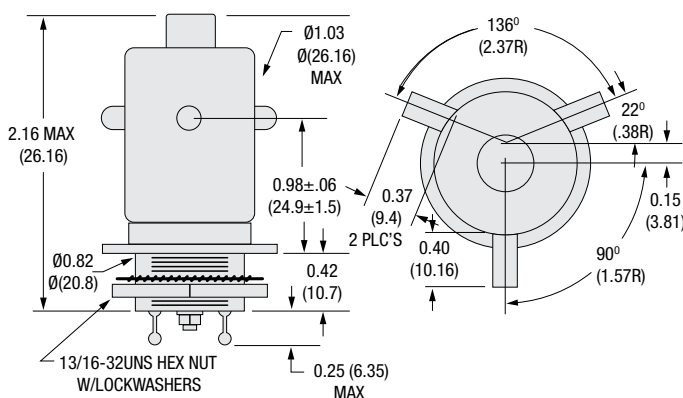

RJ4C-26S[†]

Form: Latching

Equipped with integral flange

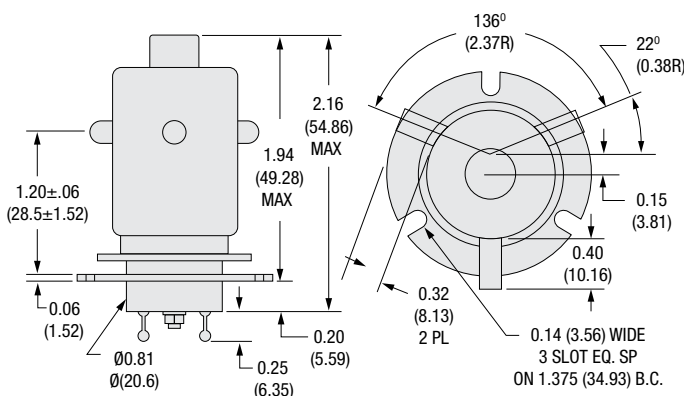

RF10B-26S

Form: SPDT

Equipped with integral flange

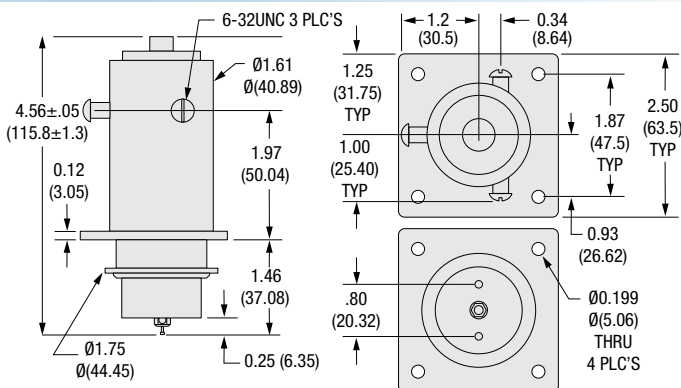

[†] Can be used for hot switch applications.

PRODUCT NUMBER	TEST VOLTAGE (kV PEAK) 60 Hz	RATED OPERATING VOLTAGE (kV PEAK)				12 or 115 VDC coil versions available for model RJ5B-26S; please contact factory for lead times. For available flange versions, the flange diameter is 1.125"											
		MAX CONT. CURRENT (Amps)				CONTACT CAPACITY (pF)		MAX CONTACT RESIST. (mΩ)	MAX OPERATE TIME (ms)	MAX RELEASE TIME (ms)	PULL-IN VOLTAGE @ 25°C (Vdc)	DROP-OUT VOLTAGE @ 25°C (Vdc)	COIL RESISTANCE (Ω ±10%)	SHOCK, 11ms ½ SINE (PEAK g's)	VIBRATION PEAK g's @ FREQ.	MECHANICAL LIFE (10 ⁶ CYCLES)	WEIGHT, oz. (grams)
		DC OR 60Hz	2.5 MHz	16 MHz	32 MHz	OPEN CONTACT TO OPEN CONTACT	OPEN CONTACTS TO GROUND										
RJ9B-26S [†]	20	15	13	10	—	3	3.5	10	30	8	16	1-10	190	50	10 @ 55-500 Hz	1	11 (312)
		110	50	20	—												
RJ5B-26S	30	25	—	—	—	6	3	50	20	15	18	1-10	167	20	10 @ 55-500 Hz	1	12 (340)
		10	—	—	—												

RJ9B-26S[†]

Form: SPDT

Equipped with integral flange

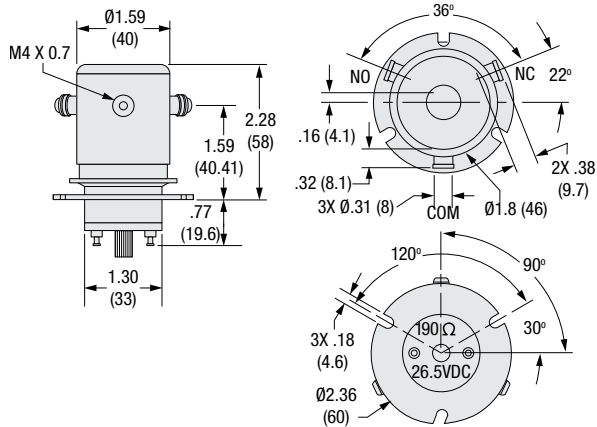

RJ5B-26S

Form: SPDT

Flange Version Available: None

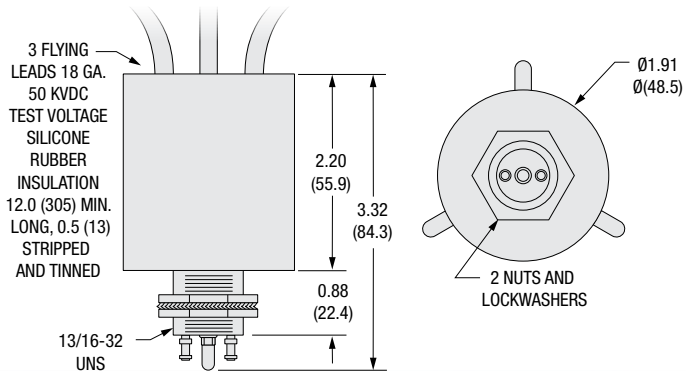

[†] Can be used for hot switch applications.



PRODUCT NUMBER	TEST VOLTAGE (kV PEAK) 60 Hz	RATED OPERATING VOLTAGE (kV PEAK)				12 VDC coil versions available for both models. 115 VDC coil version available for model RGH5-26S; please contact factory for lead times.												
		MAX CONT. CURRENT (Amps)				CONTACT CAPACITY (pF)		MAX CONTACT RESIST. (mΩ)	MAX OPERATE TIME (ms)	MAX RELEASE TIME (ms)	PULL-IN VOLTAGE @ 25°C (Vdc)	DROP-OUT VOLTAGE @ 25°C (Vdc)	COIL RESISTANCE (Ω ±10%)	SHOCK, 11ms ½ SINE (PEAK g's)	VIBRATION PEAK g's @ FREQ.	MECHANICAL LIFE (10 ⁶ CYCLES)	WEIGHT, oz. (grams)	
		DC OR 60Hz	2.5 MHz	16 MHz	32 MHz	OPEN CONTACT TO OPEN CONTACT	OPEN CONTACTS TO GROUND											
RGH5-26S*	50	40	—	—	—	6	3	500	20	15	18	1-10	167	20	10 @ 55-500 Hz	1	12 (340)	
		10	—	—	—													
RGH3-24D2524*	70	70	—	—	—	1.5	1.5	1000	N/A	15	18	16	24	30	10 @ 55-500 Hz	5	16 (454)	
		15	←-30 Make→															

RGH5-26S*

Form: SPDT
Flange Version Available: None

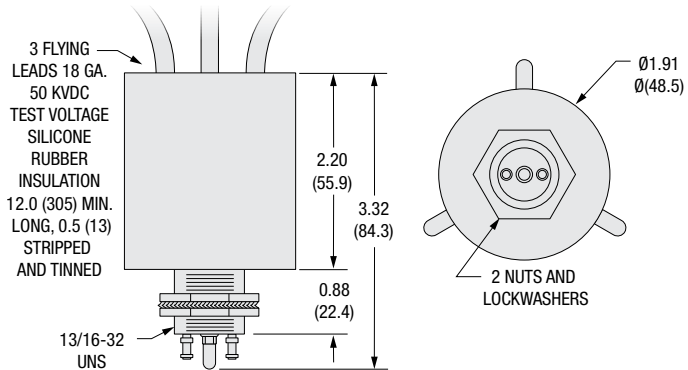

RGH3-24D2524*

Form: SPST N/C
Flange Version Available: None

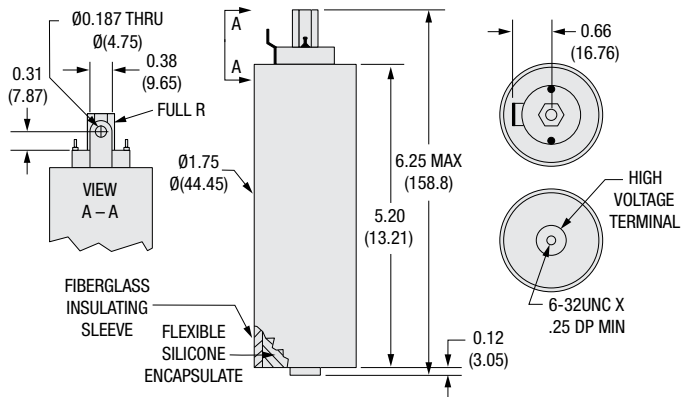

* Gas-filled relay, make-only load switching applications (CR measured at 28 VDC/1 Amp).