

# Agilent 8765A/B/C/D

## Microwave SPDT Switches

### DC to 4, 20, 26.5 and 40 GHz

#### Product Overview

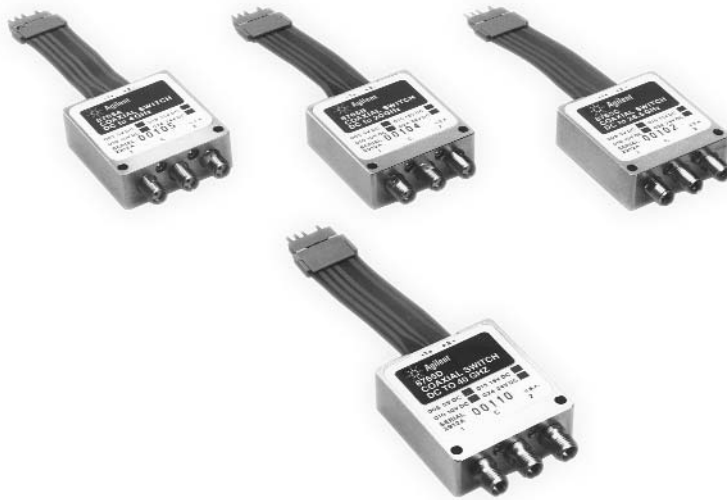

#### Features and description

- High isolation
- Exceptional reliability, long life (5 million cycles)
- Excellent repeatability ( $\pm .03$  dB)
- Unterminated

The Agilent Technologies 8765 family of switches is designed for microwave instrumentation and ATE systems and features excellent electrical and mechanical performance.

The 8765A and 8765B are equipped with SMA connectors and operate from dc to 4 and 20 GHz respectively. The higher performance 8765C and D switches operate from dc to 26.5 GHz with 3.5 mm connectors, and 40 GHz with 2.4 mm connectors.

For applications that call for 2.92 mm connectors, Option 292 can be ordered with the 8765D. All the switches are available with voltage options covering any drive voltage between 4.5 volts and 32 volts dc. Where performance data is required, Option UK6 includes a print out of test results.

This family of switches was designed from the ground up for maximum dependability and performance. The switches are all designed to operate within their specifications for more than 10,000,000 cycles. In precision measurement and monitoring applications where insertion loss repeatability is critical, all the 8765s will operate in excess of 5,000,000 cycles with better than 0.03 dB of insertion loss repeatability at 25 °C.

#### Driving the Agilent 8765A/B/C/D

The 8765 switch family is available with two methods for connecting to the dc control circuitry. The standard switch comes with a ribbon cable terminated with a single in-line five position male connector with one pin removed. The user has the option of ordering solder terminals (Option 3xx) where they are required (Figure 3). The 8765 Switches have both sides of the switching solenoids available to the user. Typically, as is the case with the 8762 switches, the switching solenoids will have a common positive terminal or a common ground. By making both sides of each coil available, users can select the dc drive method that best suits their needs. The suggested methods are:

1. Common negative drive
2. Common positive drive
3. Polarity reversal drive

Regardless of which method is chosen for switching, two conditions will always apply:

- the switch is positive latching, and
- since there are no dc current interrupts, the supply may be continuous or may be switched off after the 15 ms switching time.



**Agilent Technologies**

### Common negative drive

With the common negative drive method, the two outside pins on the ribbon cable or the two outside terminals on the solder block are connected together to form a common negative or ground. Switching is then accomplished by applying the appropriate positive voltage to either of the inner pins or terminals (figure 1a).

### Common positive drive

To drive the switch with a common positive arrangement, the two inner pins or terminals are tied together and then to a positive voltage. To effect switching, one of the two outer pins or terminals is brought to ground (figure 1a).

### Polarity reversal drive

To drive the switch using a polarity reversal scheme, the two inner pins or terminals are tied together. The switch will complete a circuit between the two RF contacts on the side of the switch to which the negative or ground potential has been connected (figure 1a).

### Interfacing the Agilent 8765

The 8765 family of switches is available with two dc control connection options. The standard switch is connected to the dc drive circuitry via a ribbon cable. Option 3xx allows soldering wires between the control circuitry and the switch.

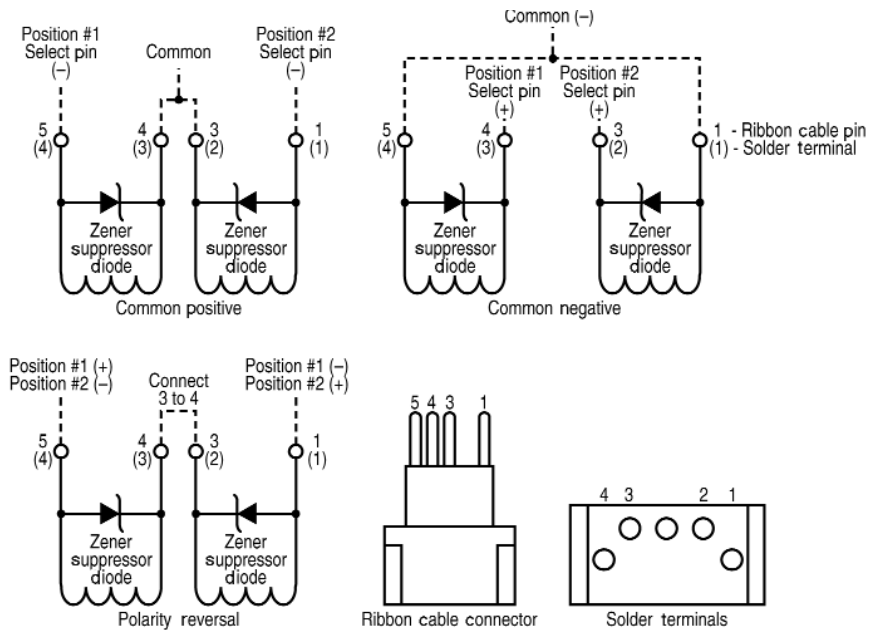

Figure 1a. DC control circuit configurations

### Ribbon cable

The kapton flex circuit ribbon cable on the standard switch is terminated to a single in-line male polarized connector with four 0.64 mm (0.025 in.) square pin posts on 2.54 mm (0.100 in.) centers. Position number 2 has been removed to facilitate polarization of the plug and receptacle (figure 1a). To assist you in connecting your drive circuit to the switch's ribbon cable connector, a six foot long four wire cable is included with every standard switch. The cable is terminated on one end with a 0.64 mm (0.025 in.) square pin receptacle. The five position receptacle is polarized to mate with the switch's ribbon cable connector. The opposite end of the cable is left unterminated for connecting to your control circuits.

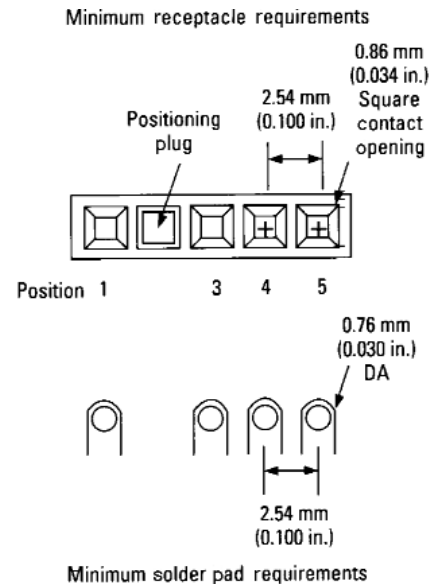

Figure 1b. Suggested receptacle dimensions

The six foot cable provides a quick and convenient way of connecting the switch to your control circuits for evaluation and low volume production. For high volume production a more convenient or more permanent connection may be suggested. Soldering the ribbon cable connector into a circuit board provides a reliable and rugged connection. Mating the ribbon cable connector to a PC board connector provides a quick to install and remove connection. The suggestions below are intended to provide minimum connection requirements. These suggestions are not endorsements or recommendations of one method over another. It is the responsibility of the user to determine the suitability for use of any interconnect method for a particular application.

### PC board connectors

PC board connectors are available in surface mount and solder pin styles and in horizontal and vertical orientations. This type of connector makes connection to and disconnection from the dc circuit quick and convenient. The connectors should be a minimum of five positions wide, and depending upon the number of switches to be connected can be any multiple of five positions (ie. 10, 15, 25, etc.). Single row or double row configurations can also be used to increase connector density. The contacts should accept 0.64 mm (0.025 in.) square pins set on 2.54 mm (0.100 in.) centers and up to 5.84 mm (0.230 in.) long. Use of a polarizing plug in the second position of each switch connection is recommended to help ensure proper orientation.

The PC board hole pattern should have the center lines of the through holes along a single axis separated by 2.54 mm  $\pm$  0.08mm (0.100 in.  $\pm$  0.003 in.). The suggested hole diameter for a 0.64 mm (0.025 in.) pin is 1.00 mm  $\pm$  0.076 mm (0.040 in.  $\pm$  0.003 in.).

Figure 1b shows a suggested receptacle dimension.

### Soldered connections

The ends of the switch ribbon cable can also be soldered directly to a PC board. This method provides a semi-permanent connection that can withstand higher vibration environments than can the PC board connectors. Omission of position 2 in the PC hole pattern is suggested to help prevent soldering the connector in the wrong orientation.

### Optional ribbon connector extension cables

Optional extension cables for the switch ribbon cable connector are available as Option 108 for an 8 inch extension and Option 116 for a 16 inch extension. The cables have male and female ends configured as indicated in figure 1a "Ribbon Cable Connector" and figure 1b "Minimum Receptacle Requirements." These ribbon cables can be connected to the dc control circuitry with the same methods suggested above.

### Optional solder terminals

Solder terminals in place of the ribbon cable for connecting to the dc control circuitry are available as Option 3xx. The four solder terminals provide access to both sides of each of the solenoids.

### Easy GPIB programmability

The Agilent 8765 switch family can be easily used in ATE systems with GPIB control using the 11713A Attenuator/Switch Driver. The 11713A provides manual and programmable control of up to 10 24 V switches or solenoids. Connecting between the 11713A and four 8765A/B/C/D Option 024 switches is made easy via the 11761A cable/adaptor. The 11713A provides 24 Vdc and 0.65A continuously or 1.3A peak (up to 1 second). The non-interrupting 8765 Option 024 draws 120 mA continuously, allowing the 11713A to drive up to five of these switches at a time. Five more dc circuit interrupting 8762/3/4s or up to five sections of step attenuators or multipoint switches can be driven simultaneously.

## Specifications

Model:	8765A	8765B	8765C	8765D
<b>Frequency range:</b>	dc to 4 GHz	dc to 20 GHz	dc to 26.5 GHz	dc to 40 GHz
<b>Insertion loss (dB):</b> (f is frequency in GHz)	0.2 + 0.025f	0.2 + 0.025f	0.25 + 0.027f	0.2 + 0.023f (dc to 26.5 GHz) 0.75 + 0.023f (26.5 to 40 GHz)
*Typical insertion loss:	0.2 @ 4 GHz	0.2 @ 4 GHz 0.5 @ 20 GHz	0.2 @ 4 GHz 0.5 @ 20 GHz 0.7 @ 26.5 GHz	0.2 @ 4 GHz 0.5 @ 20 GHz 0.7 @ 26.5 GHz 1.0 @ 40 GHz
<b>Isolation (dB):</b> (f is frequency in GHz)	110-2.25f	110-2.25f	110-2.25f	110-2.25f (dc to 26.5 GHz) 50 dB (26.5 to 40 GHz)
*Typical isolation:	120 @ 4 GHz	120 @ 4 GHz 90 @ 20 GHz	120 @ 4 GHz 90 @ 20 GHz 60 @ 26.5 GHz	120 @ 4 GHz 90 @ 20 GHz 60 @ 26.5 GHz 50 @ 40 GHz
<b>SWR:</b>	<1.2 dc to 4 GHz	<1.2 dc to 4 GHz <1.35 4 to 12.4 GHz <1.45 12.4 to 18 GHz <1.7 18 to 20 GHz	<1.25 dc to 4 GHz <1.45 4 to 18 GHz <1.7 18 to 26.5 GHz	<1.10 dc to 4 GHz <1.30 4 to 26.5 GHz <1.50 26.5 to 40 GHz
*Typical SWR:	<1.15 dc to 4 GHz	<1.15 dc to 4 GHz <1.3 4 to 12.4 GHz <1.4 12.4 to 20 GHz	<1.15 dc to 4 GHz <1.3 4 to 12.4 GHz <1.4 12.4 to 26.5 GHz	<1.05 dc to 4 GHz <1.24 4 to 26.5 GHz <1.3 26.5 to 40 GHz
<b>Connectors: standard</b> Options	SMA (f)	SMA (f)	3.5 mm (f)	2.4 mm (f) (Option 241) 2.92 mm (f) (Option 292)
<b>Repeatability:</b> (Up to 5,000,000 Cycles measured at 25 °C)	<0.03 dB	<0.03 dB	<0.03 dB	<0.03 dB

\* Specifications describe the instrument's warranted performance. Supplemental and typical characteristics are intended to provide information

### General operating data

#### Maximum power rating:

2 Watt average for switching with power applied

100 Watt peak, non-switching

Life: 10,000,000 cycles

Switching speed: 15 ms maximum

### Solenoid electrical specifications and switching voltage options

Option	Voltage	Current	Impedance
005, 305	5 (4.5 to 7) Vdc	385 mA @ 5 Vdc	13 Ω, 8 mH
010, 310	10 (7 to 12 ) Vdc	300 mA @ 10 Vdc	33 Ω, 25 mH
015, 315	15 (12 to 20) Vdc	200 mA @ 15 Vdc	75 Ω, 55 mH
024, 324	24 (20 to 30) Vdc	120 mA @ 24 Vdc	200 Ω, 135 mH

## Environmental

**Operating temperature:** -25 °C to 75 °C

**Storage temperature:** -55 °C to 85 °C

**Temperature cycling:** -55 °C to 85 °C, 10 cycles per MIL-STD 202F, Method 107D, Condition A (Modified)

### Vibration:

Operating: 7g's: 5 to 2000 Hz @ 0.25" p-p  
Survival: 20 g's: 20 to 2000 Hz @ 0.06" p-p, 4 min/cycle, 4 cycles/axis  
Random: survival: 2.41 g(rms) 10 min/axis

### Shock:

Half sine: 500 g's @ 0.5ms, 3 drops/direction, 18 total

Operating: 50 g's @ 6 ms, 6 directions

**Moisture resistance:** 65 °C, 95% RH, 10 days per MIL-STD-202F, Method 106E

**Altitude storage:** 50,000 ft (15,240 meters) per MIL-STD-202F, Method 105C, Condition B

**RFI:** Per MIL-STD-461C, RE02, Part 4

**Electrostatic discharge:** 25 kV maximum

**Abuse:** 2W, CW, 1 kw peak pulse (10 uS), 2 minute duration.

**Operating life:** To meet 0.03 dB IL repeatability: 5 million cycles. To meet specifications: 10 million cycles.

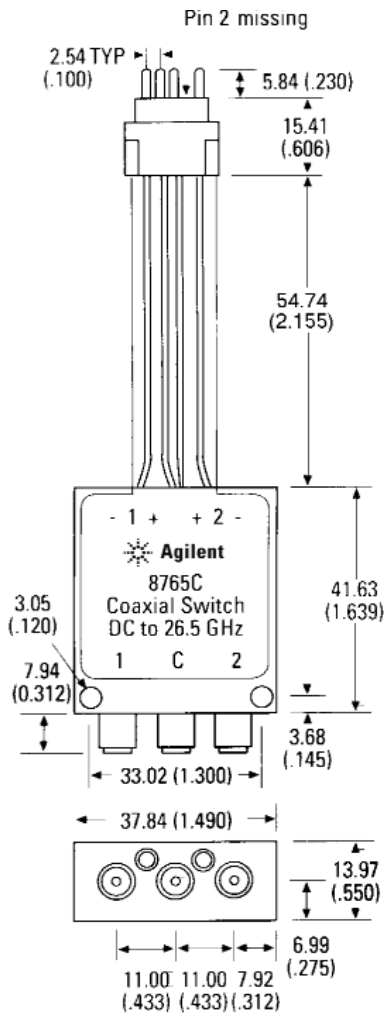

Figure 2. Standard unit part dimensions in millimeters and (inches)

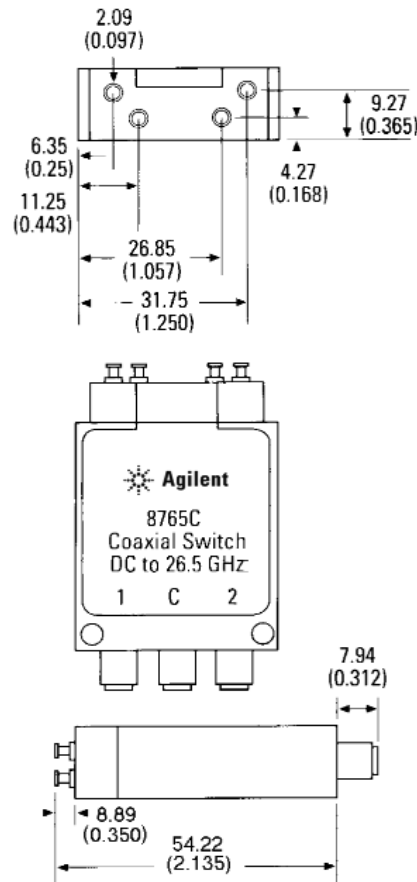

Figure 3. Option 3xx with solder terminals part dimensions in millimeters and (inches)

This drawing is not to scale.

## Ordering information

All switches must be ordered with a voltage option to be valid. Standard switches are equipped with ribbon cables terminated to a single in-line connector (see information inside data sheet for application information). All standard switches come with a six foot cable with mating connector on one end to facilitate connection to the user's control circuitry.

## Connectors

The Agilent 8765D may be ordered with optional 2.92 mm connectors in place of the 2.4 mm connectors. 2.92 mm connectors can mate with 3.5 mm connectors.

## Calibration data

Option UK6 includes a print out of the SWR (reflection) and insertion loss data for the switch as measured on the automatic network analyzer. The network analyzer's measurement uncertainties have been minimized and all measurements are directly traceable to NIST standards (not available for Option 292).

## Accessories

The Agilent 11761A Cable/Adapter is available for directly connecting the ribbon cables of up to four 8765 switches to the 11713A Attenuator/Switch Driver. This cable is 5 feet long.

The Agilent 11713A Attenuator/Switch driver is designed to provide manual and GPIB control of switches and attenuators. The 11713A can drive up to five 8765 series switches and five self-interrupting switches, such as the 8762, 3 or 4, or step attenuator sections. Option 024 switches (24V) must be ordered for use with the 11713A.

## Agilent 8765A/B/C/D options and accessories

### Microwave SPDT switches

8765A	DC to 4 GHz
8765B	DC to 20 GHz
8765C	DC to 26.5 GHz
8765D	DC to 40 GHz

### Options

To add options to a product, use the following scheme:  
Model: 8765x (x = A, B, C, D)  
Model options: 8765x-opt #1  
8765x-opt #2

### Supply voltage (must choose one)

8765x-005	5V dc supply voltage with 3 inch ribbon cable terminated with a single in-line
8765x-010	10V dc supply voltage with 3 inch ribbon cable terminated with a single in-line
8765x-015	15V dc supply voltage with 3 inch ribbon cable terminated with a single in-line
8765x-024	24V dc supply voltage with 3 inch ribbon cable terminated with a single in-line
8765x-305	5V dc supply voltage with solder terminals
8765x-310	10V dc supply voltage with solder terminals
8765x-315	15V dc supply voltage with solder terminals
8765x-324	24V dc supply voltage with solder terminals

### Calibration documentation

8765x-UK6	Commercial calibration certificate with test data
-----------	---

### Accessories

8765x-108	8 inch (20.3 cm) dc cable extension
8765x-116	16 inch (40.6 cm) dc cable extension

### RF connectors

8765D-241	2.4 mm female
8765D-292	2.92 mm female

## www.agilent.com

### Agilent Technologies' Test and Measurement Support, Services, and Assistance

Agilent Technologies aims to maximize the value you receive, while minimizing your risk and problems. We strive to ensure that you get the test and measurement capabilities you paid for and obtain the support you need. Our extensive support resources and services can help you choose the right Agilent products for your applications and apply them successfully. Every instrument and system we sell has a global warranty. Two concepts underlie Agilent's overall support policy: "Our Promise" and "Your Advantage."

### Our Promise

Our Promise means your Agilent test and measurement equipment will meet its advertised performance and functionality. When you are choosing new equipment, we will help you with product information, including realistic performance specifications and practical recommendations from experienced test engineers. When you receive your new Agilent equipment, we can help verify that it works properly and help with initial product operation.

### Your Advantage

Your Advantage means that Agilent offers a wide range of additional expert test and measurement services, which you can purchase according to your unique technical and business needs. Solve problems efficiently and gain a competitive edge by contracting with us for calibration, extra-cost upgrades, out-of-warranty repairs, and onsite education and training, as well as design, system integration, project management, and other professional engineering services. Experienced Agilent engineers and technicians worldwide can help you maximize your productivity, optimize the return on investment of your Agilent instruments and systems, and obtain dependable measurement accuracy for the life of those products.



[www.agilent.com/find/open](http://www.agilent.com/find/open)

Agilent Open simplifies the process of connecting and programming test systems to help engineers design, validate and manufacture electronic products. Agilent offers open connectivity for a broad range of system-ready instruments, open industry software, PC-standard I/O and global support, which are combined to more easily integrate test system development.

For more information on Agilent Technologies' products, applications or services, please contact your local Agilent office. The complete list is available at:

[www.agilent.com/find/contactus](http://www.agilent.com/find/contactus)



[www.agilent.com/find/emailupdates](http://www.agilent.com/find/emailupdates)

Get the latest information on the products and applications you select.

Product specifications and descriptions in this document subject to change without notice.

© Agilent Technologies, Inc. 1995, 2000, 2006  
Printed in U.S.A. August 1, 2006  
5952-2231E



Agilent Technologies