



SERIES SMC

SUBMINIATURE CONNECTORS

Description

The SUHNER SMC subminiature connector series is based on the same design as the SMB and SMS series. But due to its screw-on coupling mechanism, the SUHNER SMC subminiature connectors are suitable for applications up to 10 GHz.

Coupling mechanism:

The SMC screw-on mechanism permits a vibration-proof connection suitable for semi-permanent connections and for use in mobile equipment with low VSWR requirements.

Contents

Page

Description	101
Interface Dimensions	101
Interface Dimensions in mm / inches	101
Standards	102
Technical Data	102
Connectors for Semi-Rigid Cables	104
Connectors for Flexible Cables	105
Receptacles with Solder End	107
PCB Connectors	108
Adaptors Within-Series	110
Terminations	112

Interface Dimensions

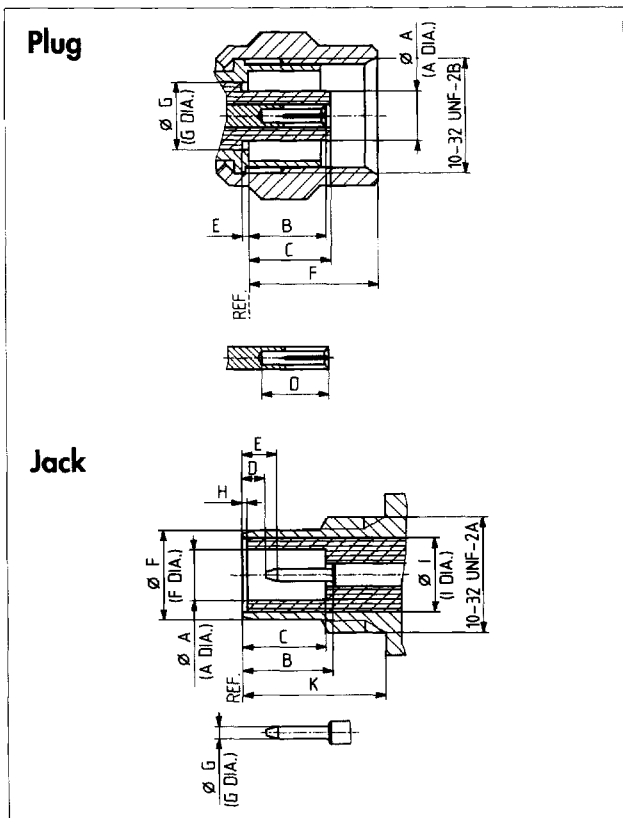

Interface Dimensions in mm / inches

	Plug		Jack	
	min.	max.	min.	max.
A	—	2.60/.081	2.08/.082	—
B	2.85/.112	3.40/.134	3.40/.134	—
C	—	3.40/.134	3.40/.134	—
D	2.79/.110	—	0.61/.024	—
E	0.00/.000	—	—	2.13/.084
F	—	5.92/.233	—	3.71/.146
G	3.05/.120 nom.		0.48/.019	0.53/.021
H	—	—	0.00/.000	—
I	—	—	3.05/.120 nom.	
K	—	—	5.94/.234	—

These products are mentioned in the List of Preferred Products of CECC/MUAHAG.

Standards

MIL-C-39012 SMC,
 Interface MIL-STD-348A/312
 IEC 169-9
 CECC 22140
 BS 9210 N 0009 SMC
 DIN 47225
 NFC 93561 series KMV
 VG 95286

Technical Data

ELECTRICAL DATA CABLE DIELECTRIC DIAMETER	REQUIREMENTS 0.87 MM / .034 IN.	REQUIREMENTS 1.5 MM / .059 IN.
Impedance	50 Ω	
Frequency range	DC ... 10 GHz (see also Appendix page 436)	
VSWR	see table below	
Insertion loss	see Appendix page 437	
RF-leakage (measured at 1 GHz)	≥ 90 dB	
Dielectric withstanding voltage (at sea level)	750 V rms, 50 Hz	1000 V rms, 50 Hz
Working voltage (at sea level) – unmated	≤ 250 V rms, 50 Hz	≤ 335 V rms, 50 Hz
Working voltage (at sea level) – unmated	≤ 350 V DC	≤ 450 V DC
Insulation resistance	$\geq 10^4$ M Ω	
Contact resistance – centre contact – outer contact	≤ 6 m Ω ≤ 1 m Ω	

TYPICAL VSWR CONNECTOR TYPE	FREQUENCY RANGE				CABLE GROUP
	1 GHz	2.5 GHz	5 GHz	10 GHz	
straight connectors	1.07	1.15	1.19	1.25	Y3, Y11
	1.15	1.38	1.43		U1
right angle connectors	1.07	1.10	1.25		U2, U4
	1.07	1.10	1.12	1.35	Y3, Y11
	1.15	1.38	1.43		U1
	1.09	1.12	1.18		U2, U4

MECHANICAL DATA	REQUIREMENTS
Coupling nut torque – recommended – proof torque	25 Ncm ... 35 Ncm / 2.2 in.-lbs ... 3.1 in.-lbs 71 Ncm / 6.2 in.-lbs
Coupling nut retention force	≥ 160 N / 36.0 lbs
Contact captivation	≥ 18 N / 4.0 lbs
Cable retention force ¹⁾	see pages 36 – 41
Durability (matings)	≥ 500

1) value considers maximum load of the cables without irreversible variations of specifications.

ENVIRONMENTAL DATA	TEST CONDITIONS
Temperature range	– 65° C ... + 165° C / –85° F ... + 329° F
Climatic category acc. to IEC	55 / 155 / 21
Thermal shock	MIL-STD-202, Method 107, Condition C
Moisture resistance	MIL-STD-202, Method 106
Corrosion	Saltspray test acc. to MIL-STD-202, Method 101, Condition B
Vibration	MIL-STD-202, Method 204, Condition D

MATERIAL DATA			
CONNECTOR PART	STANDARDS	MATERIAL	PLATING
Bodies, pin contact	QQ-B-626	brass	gold*
Socket contact	QQ-C-530	beryllium-copper, hardened	gold
Crimp ferrule (SUHNER® crimp)	SUHNER® specification	copper	gold
Springs and washers	QQ-C-530	beryllium-copper, hardened	gold
Insulators	ASTM-D-1457, BS 4271 Grade B	PTFE	
Gaskets (SUHNER® pressure-sleeve)	ASTM-E-1418 PS 1	silicone rubber	

*standard plating (other platings available)

Some connectors may have a specification that differs from the above mentioned data.

Connectors for Semi-Rigid Cables

straight plug

- > cable entry soldered
- > centre contact soldered

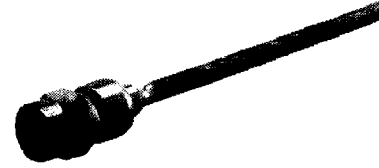
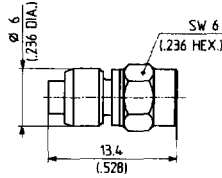

SUMNER TYPE	Ident. no.	Cable group (example)	Assembly instruction	Weight	Notes
11 SMC-30-2-13	543363	Y3, Y11 (EZ 86)	9002	1.90 g/.067 oz.	

right angle plug

- > cable entry soldered
- > centre contact soldered

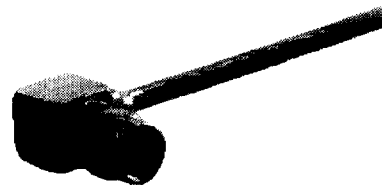
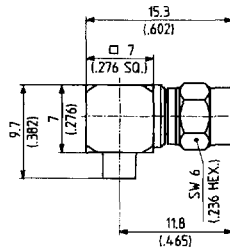

SUMNER TYPE	Ident. no.	Cable group (example)	Assembly instruction	Weight	Notes
16 SMC-30-2-25	644126	Y3, Y11 (EZ 86)	9160	4.00 g/.140 oz.	

bulkhead jack

- > cable entry soldered
- > centre contact soldered

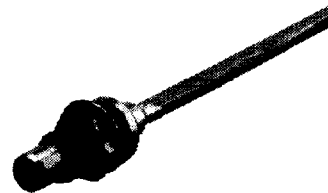
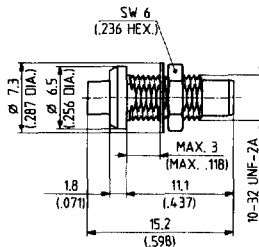

SUMNER TYPE	Ident. no.	Cable group (example)	Assembly instruction	Mounting hole	Weight	Notes
24 SMC-30-2-13	640297	Y3, Y11 (EZ 86)	9002	ML 11	1.50 g/.053 oz.	

- centre contact captivated

Connectors for Flexible Cables

straight plugs

> SUHNER® full crimp

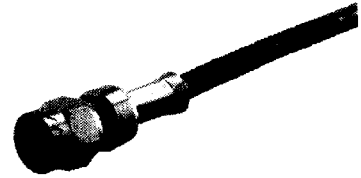
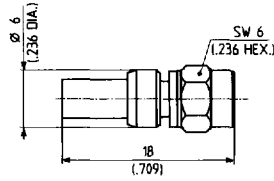

SUHNER TYPE	Ident. no.	Cable group (example)	MIL M 39012/	Crimp insert	Assembly instruction	Weight	Notes
11 SMC-50-1-10	640239	U1 (RG 178 B/U)		1/2 A	3077	2.10 g/.074 oz.	
11 SMC-50-2-10/111	640811	U2 (RG 316/U)	73B0009	1/2 A	3077	2.10 g/.074 oz.	
11 SMC-50-2-10/133	641528	U2 (RG 316/U)		1/2 A	3077	2.10 g/.074 oz.	SUCOPLATE®
11 SMC-50-2-11	640251	U4 (K 02252 D)		1/2 A	3077	2.10 g/.074 oz.	

> cable entry SUHNER® pressure-sleeve

> centre contact soldered

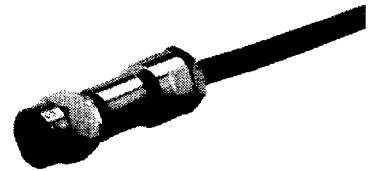
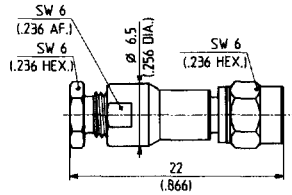

SUHNER TYPE	Ident. no.	Cable group (example)	MIL M 39012/	Assembly instruction	Weight	Notes
11 SMC-50-1-6	640238	U1 (RG 178 B/U)	73-0003	3041	2.70 g/.095 oz.	
11 SMC-50-2-5	640246	U2 (RG 316/U)	73-0004	3041	2.70 g/.095 oz.	

right angle plugs

> SUHNER® full crimp

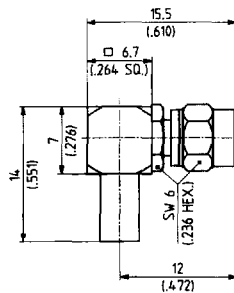

SUHNER TYPE	Ident. no.	Cable group (example)	MIL M 39012/	Crimp insert	Assembly instruction	Weight	Notes
16 SMC-50-1-10	543364	U1 (RG 178 B/U)		1/2 A	3096	3.80 g/.133 oz.	
16 SMC-50-2-10	640269	U2 (RG 316/U)	75B0009	1/2 A	3096	3.80 g/.133 oz.	
16 SMC-50-2-11	543366	U4 (K 02252 D)		1/2 A	3096	3.80 g/.133 oz.	

• centre contact captivated

- > cable entry crimp
- > centre contact soldered

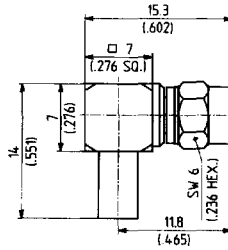

SUHNER TYPE	Ident. no.	Cable group (example)	Crimp insert	Assembly instruction	Weight	Notes
16 SMC-50-1-20	644083	U1 (RG 178 B/U)	A	9157	3.80 g/.133 oz.	
16 SMC-50-2-20	643949	U2 (RG 316/U)	A	9157	3.80 g/.133 oz.	

- > cable entry SUHNER® pressure-sleeve
- > centre contact soldered

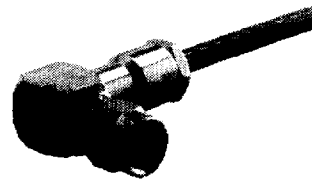
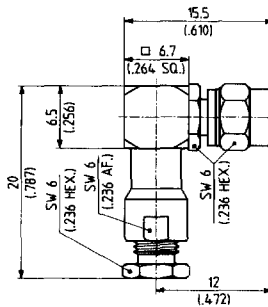

SUHNER TYPE	Ident. no.	Cable group (example)	MIL M 39012/	Assembly instruction	Weight	Notes
16 SMC-50-2-5	640264	U2 (RG 316/U)	75-0004	3039	5.00 g/.175 oz.	replaces UG-1466/U

straight jacks

- > SUHNER® full crimp

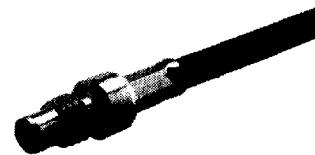
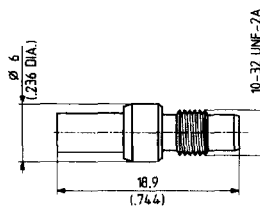

SUHNER TYPE	Ident. no.	Cable group (example)	MIL M 39012/	Crimp insert	Assembly instruction	Weight	Notes
21 SMC-50-2-10	640279	U2 (RG 316/U)	74B0009	1/2 A	3077	1.70 g/.060 oz.	
21 SMC-50-2-11	644232	U4 (K 02252 D)		1/2 A	3077	1.70 g/.060 oz.	

- centre contact captivated

bulkhead jacks

- > SUHNER® full crimp
- > rear mounting

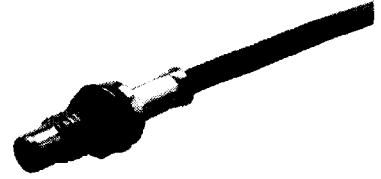
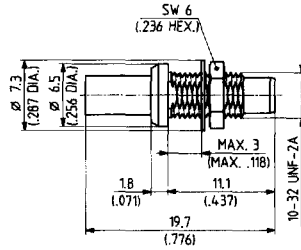

SUHNER TYPE	Ident. no.	Cable group (example)	MIL M 39012/	Crimp insert	Assembly instruction	Weight	Notes
24 SMC-50-1-10	640290	U1 (RG 178 B/U)		1/2 A	3077	1.80 g/.063 oz.	
24 SMC-50-2-10/111	640296	U2 (RG 316/U)	76B0009	1/2 A	3077	1.80 g/.063 oz.	
24 SMC-50-2-10/133	641690	U2 (RG 316/U)		1/2 A	3077	1.80 g/.063 oz.	SUCOPLATE®
24 SMC-50-2-11	640295	U4 (K 02252 D)		1/2 A	3077	1.80 g/.063 oz.	

mounting hole ML 11

SMC

Receptacles with Solder End

receptacles, female

- > bulkhead mounted
- > front mounting
- > suitable insulating washer 77 Z-0-0-21

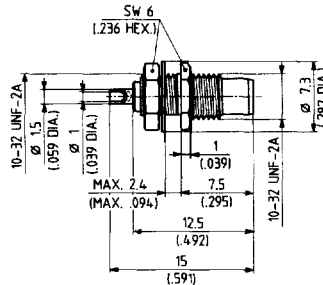

SUHNER TYPE	Ident. no.	MIL M 39012/	Mounting hole	Weight	Notes
22 SMC-50-0-2	640281	77-0002	ML 11	1.20 g/.042 oz.	replaces UG-1464/U

- > bulkhead mounted
- > rear mounting
- > suitable insulating washer 77 Z-0-0-21

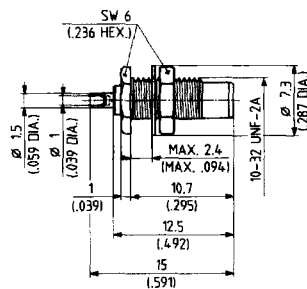

SUHNER TYPE	Ident. no.	MIL M 39012/	Mounting hole	Weight	Notes
22 SMC-50-0-3	640282	77-0001	ML 11	1.20 g/.042 oz.	replaces UG-1619/U

- centre contact captivated

cable groups see pages 36

assembly tools see page 403

mounting holes see page 441

- > bulkhead mounted
- > hermetically sealed
- > suitable for microstrip-circuits for direct soldering

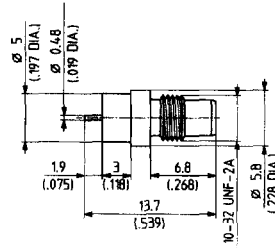

SUMNER TYPE	Ident. no.	VSWR DC...3 GHz	3...4 GHz	Mounting hole	Weight	Notes
22 SMC-50-0-3	640285	≤ 1.2	≤ 1.4	ML 90	1.00 g / .035 oz.	leak rate ≤ 10 ⁻⁸ Torr. l/sec (atm cc/s) soldering temperature max. 250°C / 482°C

PCB Connectors

straight PCB plug

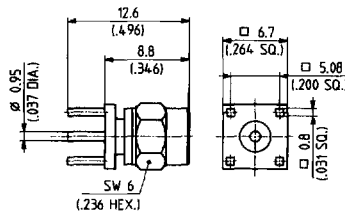

SUMNER TYPE	Ident. no.	Mounting hole	Weight	Notes
81 SMC-50-0-1	640312	ML 15	1.30 g / .046 oz.	without stand-offs

straight PCB jack

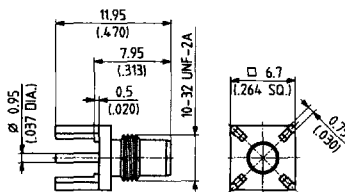

SUMNER TYPE	Ident. no.	Mounting hole	Weight	Notes
82 SMC-50-0-1	640313	ML 15	0.90 g / .032 oz.	

- centre contact captivated

right angle PCB plug

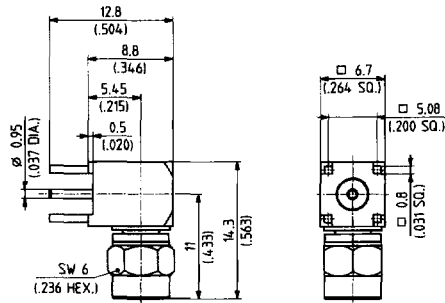

SUHNER TYPE	Ident. no.	Mounting hole	Weight	Notes
84 SMC-50-0-1	543643	ML 15	3.50 g/.123 oz.	

right angle PCB jacks

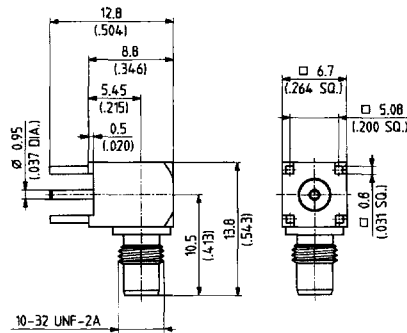

SUHNER TYPE	Ident. no.	Mounting hole	Weight	Notes
85 SMC-50-0-1/111	640326	ML 15	3.10 g/.109 oz.	
85 SMC-50-0-1/133	642472	ML 15	3.10 g/.109 oz.	SUCOPLATE®

PCB cable terminators

> outer contact crimped

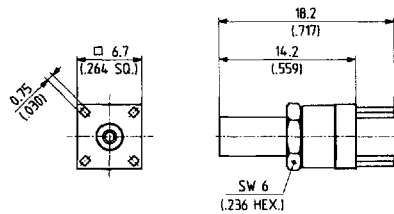

SUHNER TYPE	Ident. no.	Cable group (example)	Assembly instruction	Mounting hole	Weight	Crimp tool
83 SMC-0-2-2	640317	U2 (RG 316/U)	3052	ML 15	2.30 g/.081 oz.	insert A
83 SMC-0-2-7	643477	U4 (K 02252 D)	3052	ML 15	2.30 g/.081 oz.	insert A

cable assembly is possible after soldering to PCB

• centre contact captivated

right angle PCB cable terminators

> outer contact crimped

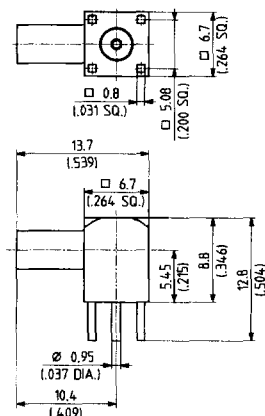

SUHNER TYPE	Ident. no.	Cable group (example)	Assembly instruction	Mounting hole	Weight	Crimp tool
86 SMC-50-1-2	• 640322	U1 (RG 178 B/U)	3048	ML 15	3.00 g/.105 oz.	insert A
86 SMC-50-2-2	• 640325	U2 (RG 316/U)	3048	ML 15	3.00 g/.105 oz.	insert A
86 SMC-50-2-7	• 640328	U4 (K 02252 D)	3048	ML 15	3.00 g/.105 oz.	insert A

complete cable assembly before soldering to PCB

tool for assembly of cap 74 Z-0-0-

Adaptors Within-Series

straight adaptors

> jack to jack

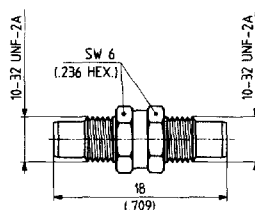

SUHNER TYPE	Ident. no.	VSWR DC-10 GHz	Weight	Notes
31 SMC-50-0-1	• 640300	1.08 + 0.15 f (f = GHz)	1.90 g/.067 oz.	

> plug to plug

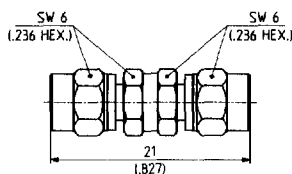

SUHNER TYPE	Ident. no.	VSWR DC-10 GHz	Weight	Notes
32 SMC-50-0-1	• 543822	1.08 + 0.10 f (f = GHz)	2.80 g/.098 oz.	

• centre contact captivated

cable groups see page 36

assembly tools see page 403

mounting holes see page 441

- > jack to jack
- > bulkhead mounted

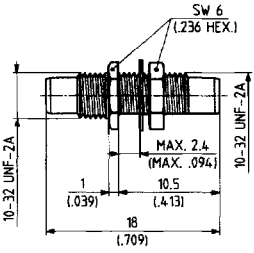

Fig. 1

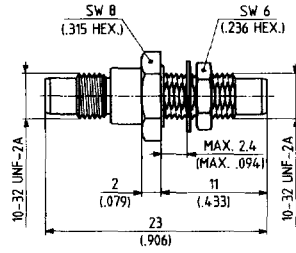

Fig. 2



SUHNER TYPE	Ident. no.	VSWR (DC – 10 GHz)	Weight	Fig.	Notes
34 SMC-50-0-2	• 640302	1.03 + 0.04f (f = GHz)	1.50 g/.053 oz.	1	suitable for insulated mounting
34 SMC-50-0-3	• 640303	1.14 + 0.11f (f = GHz)	1.50 g/.053 oz.	2	hermetically sealed*

* leak rate 10⁻⁶ Torr l/sec. (atm cc/s) max.

mounting hole ML 11

T-adaptors

50 Ω nominal impedance. These connectors are non-matched 3 dB dividers for LF applications. VSWR ≥ 2.0 when terminated with 50 Ω.

- > 1 plug, 2 jacks

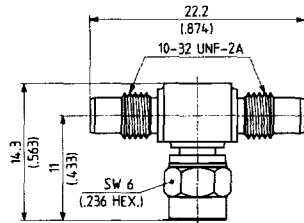

SUHNER TYPE	Ident. no.	Weight	Notes
43 SMC-50-0-2	• 640305	3.70 g/.130 oz.	

- > 3 jacks

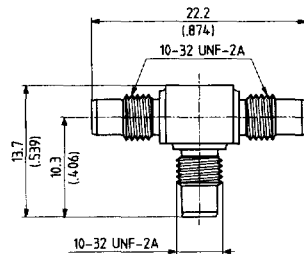

SUHNER TYPE	Ident. no.	Weight	Notes
46 SMC-50-0-2	• 640307	3.20 g/.112 oz.	

• centre contact pivoted

cable groups see pages 36

assembly tools see page 403

mounting holes see page 441

Terminations

50 Ω, plug

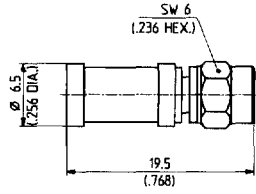

SUMNER TYPE	Ident. no.	VSWR		Interface	Impedance	Power	Weight
		DC - 2 GHz	- 4 GHz				
65 SMC-30-0-1	550113	≤ 1.05	≤ 1.20	plug	50 Ω ± 1 Ω	0.5 Watt*	2.70 g / .095 oz.

* at max. 30°C/86°F ambient temperature, derated linearly to zero watt at 130°C/266°F ambient temperature

50 Ω, jack

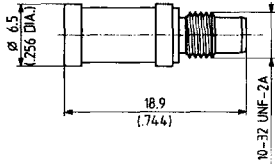

SUMNER TYPE	Ident. no.	VSWR		Interface	Impedance	Power	Weight
		DC - 2 GHz	- 4 GHz				
65 SMC-30-0-31	652096	≤ 1.05	≤ 1.20	jack	50 Ω ± 1 Ω	0.5 Watt*	2.20 g / .077 oz.

* at max. 30°C/86°F ambient temperature, derated linearly to zero watt at 130°C/266°F ambient temperature

- centre contact captivated