

Film dielectric trimmers

2222 808
 Ø7.5 mm

FEATURES

- Housing diameter 7.5 mm
- For a basic grid of 2.54 mm (0.1") or 2.50 mm
- Top and bottom or top adjustment
- Vertical and horizontal versions
- Round or hexagonal head.

APPLICATIONS

- For consumer and industrial equipment.

DESCRIPTION

The vanes of the trimmer are stacked on a sturdy plastic base. The colour of the base indicates the maximum capacitance (see Table 2). The dielectric is a film of polypropylene (PP), polyethylene (PE), polycarbonate (PC), polytetrafluorethylene (PTFE), or polyethyleneterephthalate (PET) which supports the vanes in such a way that good stability is ensured and no microphony can occur.

Flux absorption between the vanes is prevented.

Cleaning with solvents is not advised.

Versions are available with either a vertical spindle (see Fig.1), or a horizontal spindle (see Fig.2). Both versions have top adjustment by means of a screwdriver or trimming key and bottom adjustment by means of a key as shown in Fig.5.

For outline drawings and dimensions see Figs 1 and 2.

QUICK REFERENCE DATA

DESCRIPTION	VALUE
C_{min}/C_{max}	1.4/5.5 to 3/50 pF
Rated voltage (DC)	250 V
Test voltage (DC) for 1 minute	500 V
Maximum contact resistance	10 mΩ
Minimum insulation resistance	10000 MΩ
Category temperature range:	
PP	-40 to +70 °C
PE, PC, PTFE, PET	-40 to +85 °C
Climatic category (IEC 60068):	
PP	40/070/21
PE, PC, PTFE, PET	40/085/21
Minimum storage temperature	-55 °C
Related specification	IEC 60418-1 and 4

MECHANICAL DATA

DESCRIPTION	VALUE
Effective angle of rotation	180°
Operating torque:	
$C_{max} < 33$ pF	1 to 15 mNm
$C_{max} \geq 33$ pF	1 to 25 mNm
Maximum axial thrust	2 N

QUALITY LEVEL

Sampling and data evaluation for quality level in accordance with "MIL-STD-105D" and "IEC 60410".

<0.15% major defects

<0.65% minor defects.

Each capacitor is tested for minimum C_{max} and is also subjected to the full test voltage.

Film dielectric trimmers

2222 808
 $\varnothing 7.5$ mm

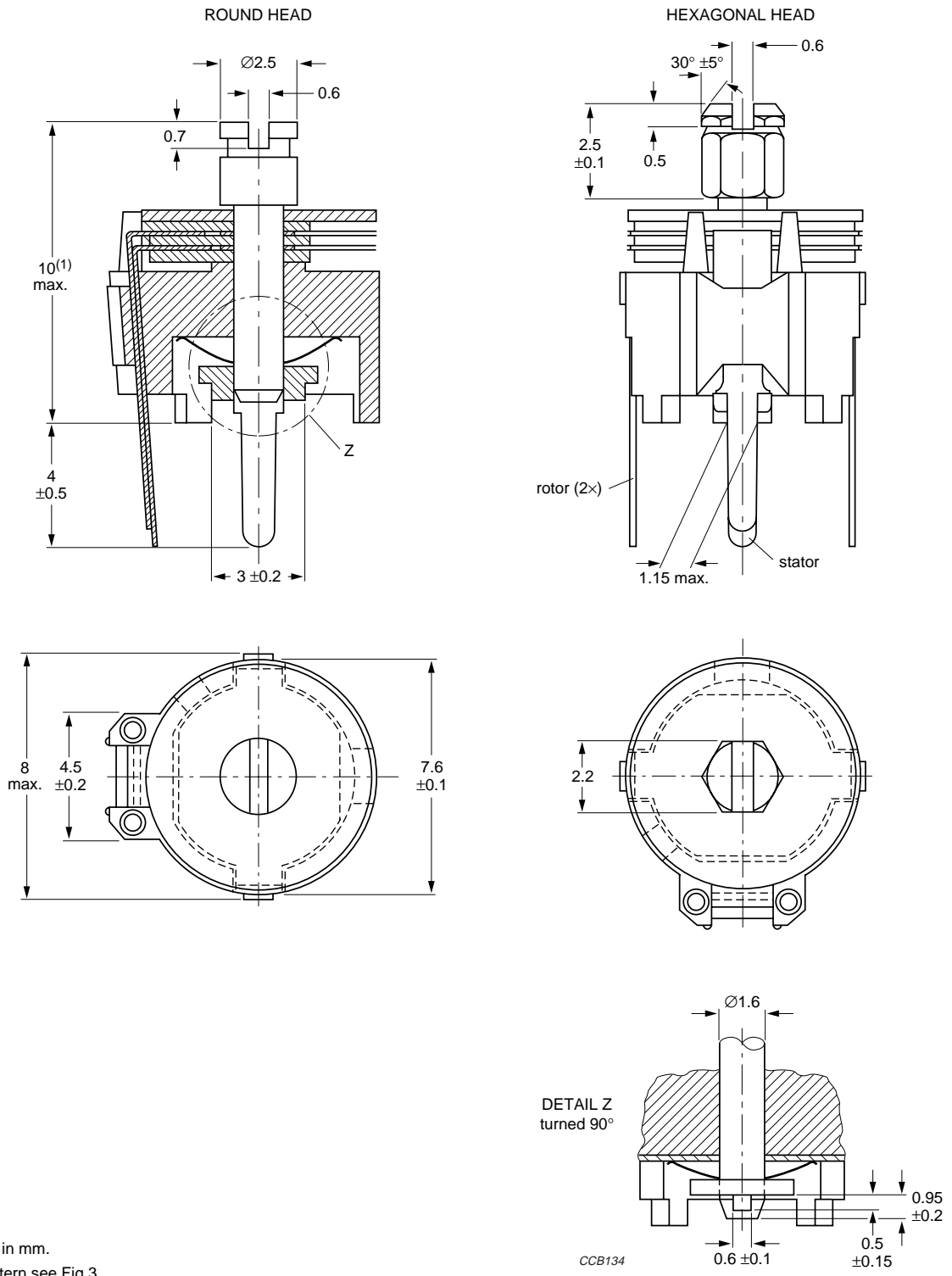

Dimensions in mm.
 For hole pattern see Fig.3.
 (1) 11 max. for $C_{max} = 40$ pF and 50 pF.

Fig.1 Trimmers 2222 808 series, vertical version.

Film dielectric trimmers

2222 808
 Ø7.5 mm

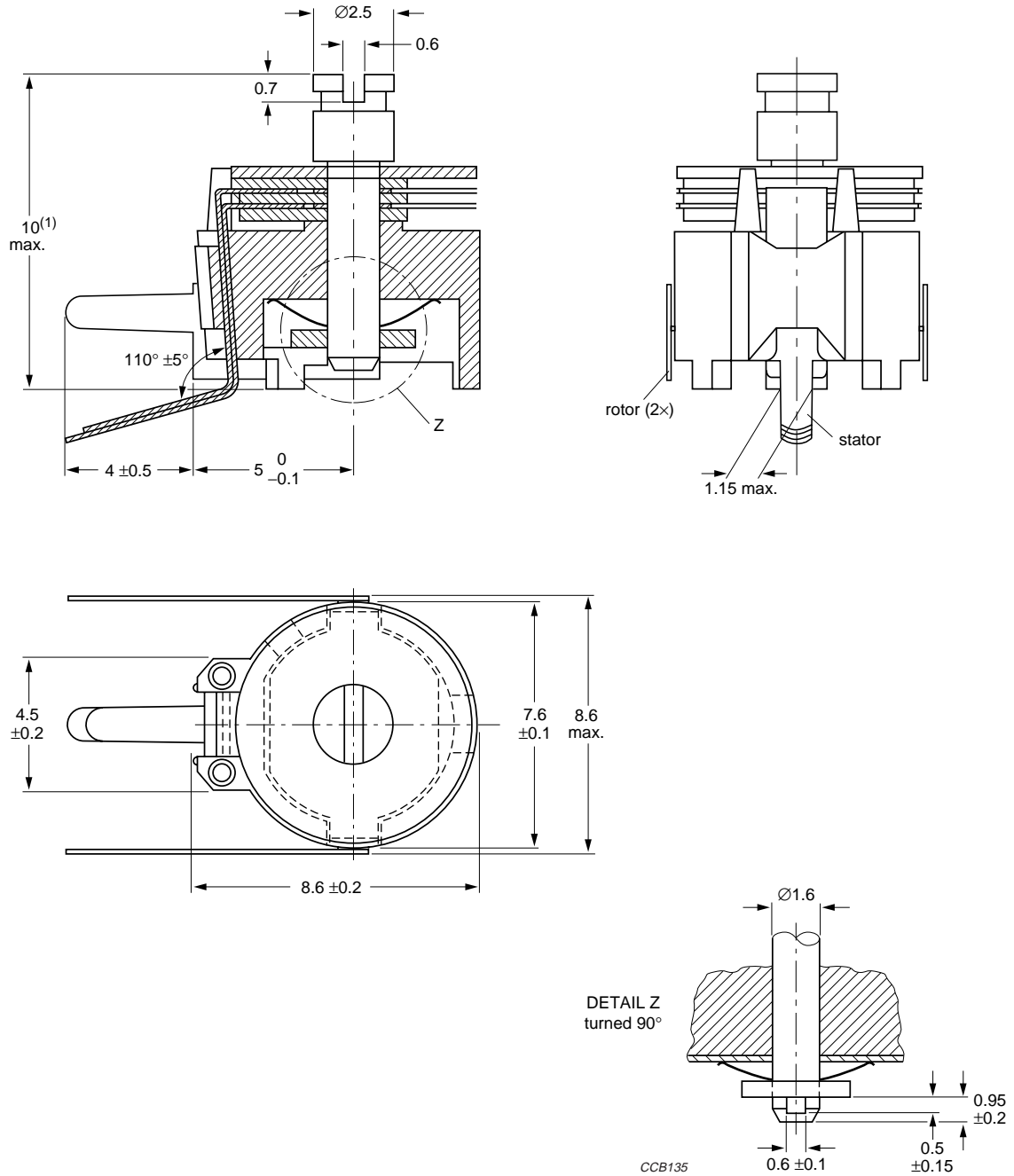

Dimensions in mm.

For hole pattern see Fig.4.

(1) 11 max. for C_{max} = 40 pF and 50 pF.

Fig.2 Trimmers 2222 808 series, horizontal version.

Film dielectric trimmers

2222 808
 Ø7.5 mm

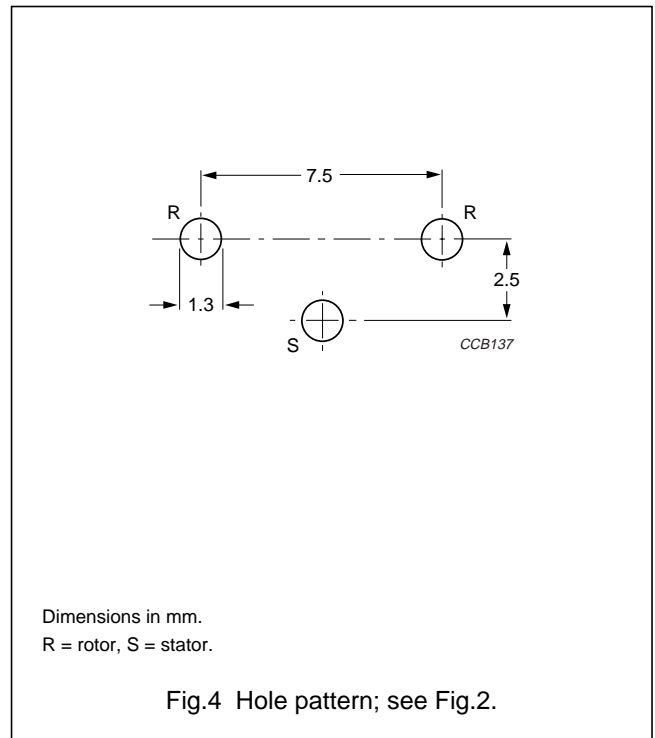
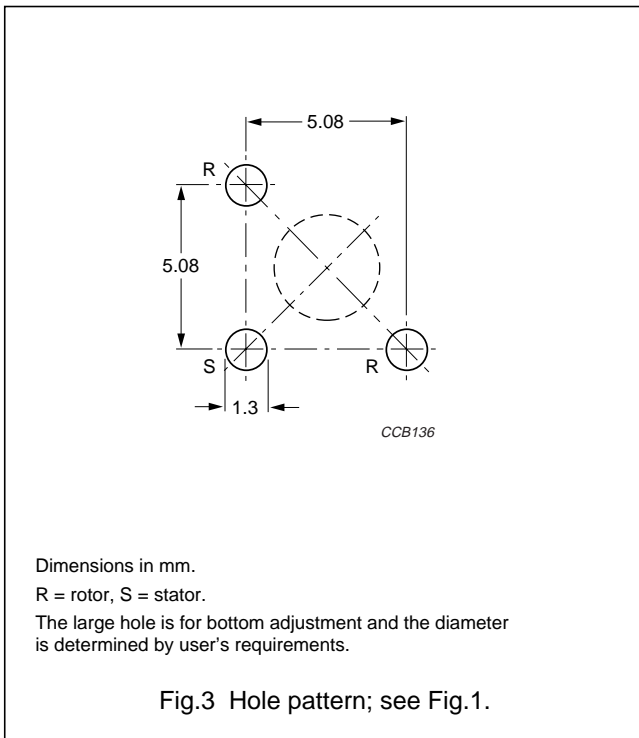

Adjustment

For top adjustment a screwdriver or trimming key can be used; for bottom adjustment a key is required as shown in Fig.5.

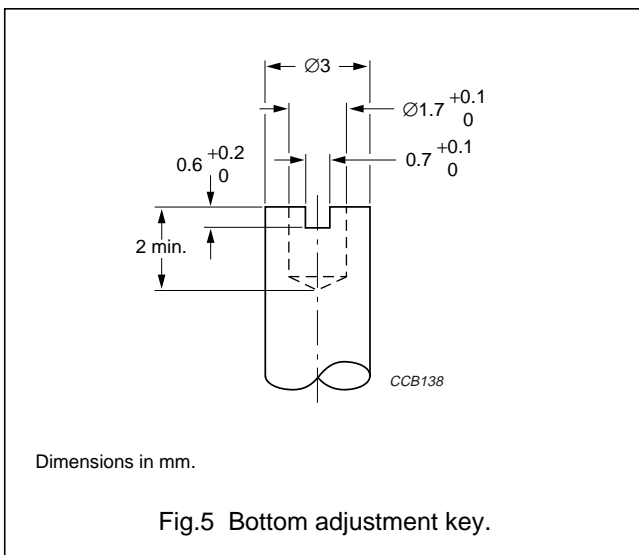

Film dielectric trimmers

2222 808
Ø7.5 mm

ORDERING INFORMATION

Table 1 Selection chart

C _{min} /C _{max} (pF)	CATALOGUE NUMBER 2222 808			
	VERTICAL VERSION			HORIZONTAL VERSION
	ROUND HEAD		HEXAGONAL HEAD	ROUND HEAD
	TOP AND BOTTOM ADJUSTMENT	TOP ADJUSTMENT ONLY	TOP AND BOTTOM ADJUSTMENT	TOP AND BOTTOM ADJUSTMENT
1.4/5.5	11558	00004	–	51558
2/9	00018	–	–	–
2/10	11109	00005	17109	51109
2/10	–	11004	–	–
2/15	11159	–	–	–
2/18	00016	–	–	–
2.5/20	–	11006	–	–
2.5/22	11229	00006	17229	51229
2.5/27	11279	–	–	51279
3/33	11339	–	–	–
3/40	11409	–	17409	51409
3/50	11509	–	17509	51509

MOUNTING

The trimmer can be mounted on printed-circuit boards with a grid of 2.50 mm or 2.54 mm and a minimum hole diameter of 1.25 mm. For hole patterns see Figs 3 and 4.

PACKAGING

Bulk packaged in cardboard boxes lined with expanded plastic. For smallest packaging quantity (SPQ) see Table 2.

Film dielectric trimmers

2222 808
Ø7.5 mm

ELECTRICAL DATA

Table 2 Electrical characteristics, smallest packaging quantities and catalogue numbers

GUARANTEED MAX. C _{min} / MIN. C _{max} at 200 kHz (pF)	SPINDLE	SHAPE OF HEAD	FIG.	ADJ. MODE	DIEL.	tan δ at C _{max} × 10 ⁻⁴		TEMP. COEFF. (10 ⁻⁶ /K)	MIN. f _{res} at C _{max} (MHz)	COL. OF BASE	SPQ	CATALOGUE NUMBER
						1 MHz	100 MHz					
1.4/5.5	vertical	round	1	top + bottom	PE	≤10	≤25	-250 ±350	850	grey	1400	2222 808 11558
			1	top							1400	2222 808 00004
	horizontal	round	2	top + bottom	1200	2222 808 51558						
2/9	vertical	round	1	top + bottom	PTFE	≤10	≤15	-150 ±800	400	yellow	1400	2222 808 00018
2/10	vertical	round	1	top + bottom	PP	≤10	≤25	-250 ±800	480	yellow	1400	2222 808 11109
			1	top							1400	2222 808 00005
	hexag.	1	top	1400							2222 808 17109	
	horizontal	round	2	top + bottom							1200	2222 808 51109
	vertical	round	1	top	PC	≤70	≤100	-150 ±800	250	yellow	1000	2222 808 11004
2/15	vertical	round	1	top + bottom	PP	≤10	≤25	-250 ±600	450	blue	1400	2222 808 11159
2/18	vertical	round	1	top + bottom	PTFE	≤10	≤15	-250 ±350	350	green	1400	2222 808 00016
2.5/20	vertical	round	1	top	PET	≤160	-	0 ±1100	250	green	1000	2222 808 11006
2.5/22	vertical	round	1	top + bottom	PP	≤10	≤25	-200 ±500	350	green	1400	2222 808 11229
			1	top							1400	2222 808 00006
	vertical	hexag.	1	top							1400	2222 808 17229
	horizontal	round	2	top + bottom							1200	2222 808 51229
2.5/27	vertical	round	1	top + bottom	PC	≤70	-	-50 ±500	350	red	1400	2222 808 11279
	horizontal	round	2	top + bottom							1200	2222 808 51279
3/33	vertical	round	1	top + bottom	PP	≤10	-	-250 ±350	300	brown	1400	2222 808 11339
3/40	vertical	round	1	top + bottom	PC	≤70	-	-50 ±400	300	violet	1400	2222 808 11409
	vertical	hexag.	1	top							1400	2222 808 17409
	horizontal	round	2	top + bottom							1200	2222 808 51409
3/50	vertical	round	1	top + bottom	PC	≤70	-	-50 ±500	250	black	1400	2222 808 11509
	vertical	hexag.	1	top							1400	2222 808 17509
	horizontal	round	2	top + bottom							1200	2222 808 51509

Film dielectric trimmers

2222 808
Ø7.5 mm

TESTS AND REQUIREMENTS

Table 3 Test procedures and requirements

IEC 60418-1 CLAUSE	IEC 60068 TEST METHOD	TEST	PROCEDURE	REQUIREMENTS
4.2		method of mounting	method A	
14		capacitance drift	after TC measurement	$\Delta C/C: \leq 1\%$ for $C_{\max} < 40$ pF; $\Delta C/C: \leq 2.5\%$ for $C_{\max} \geq 40$ pF
19		thrust	axial thrust of 2 N	$\Delta C/C: \leq 0.3\%$
21		robustness of terminations:		
21.1	Ua	tensile	1 N	no damage
21.2	Ub	bending	1 cycle	no damage
22	Na	rapid change of temperature	1 cycle; 0.5 hours at lower and 0.5 hours at upper category temperature	$\Delta C/C: \leq 2\%$
23	T	soldering:		
	Ta	solderability	solder bath immersion 3 mm; 235 °C; 2 s	good wetting no mechanical damage
	Tb	resistance to heat	solder bath: 260 °C; 10 s	no mechanical damage
24	Eb	impact bump	4000 ±10 bumps; 40 g; 6 ms	$\Delta C/C: \leq 0.6\%$; no mechanical damage
25	Fc	vibration	frequency 10 to 55 Hz; amplitude 0.35 mm; 1.5 hours	$\Delta C/C: \leq 0.6\%$; no mechanical damage
26		climatic sequence:		$\Delta C/C: \leq 4$
26.1	B	dry heat	16 hours at upper category temperature	$\tan \delta: \leq 10 \times 10^{-4}$ for $C_{\max} < 27$ pF; $\tan \delta: \leq 70 \times 10^{-4}$ for $C_{\max} \geq 27$ pF; $\tan \delta: \leq 80 \times 10^{-4}$ for $C_{\max} \geq 40$ pF $R_{\text{ins.}}: \geq 10000$ MΩ; rotor contact R: ≤ 10 mΩ
26.2	D	damp heat accelerated, first cycle	1 cycle; 24 hours; +40 °C; 95 to 100% RH	voltage proof: 500 V for 1 minute
26.3	Aa	cold	16 hours; -40 °C	visual examination: no mechanical damage
26.5		damp heat accelerated, remaining cycles	1 cycle; 24 hours; +40 °C; 95 to 100% RH	operating torque: 1 to 15 mNm for $C_{\max} < 33$ pF; 1 to 25 mNm for $C_{\max} \geq 33$ pF

Film dielectric trimmers

2222 808
Ø7.5 mm

IEC 60418-1 CLAUSE	IEC 60068 TEST METHOD	TEST	PROCEDURE	REQUIREMENTS
27	Ca	damp heat steady state	21 days; +40 °C; 90 to 95% RH	$\Delta C/C: \leq 5\%$ $\tan \delta: \leq 30 \times 10^{-4}$ for $C_{\max} < 27 \text{ pF}$; $\tan \delta: \leq 70 \times 10^{-4}$ for $C_{\max} \geq 27 \text{ pF}$; $\tan \delta: \leq 80 \times 10^{-4}$ for $C_{\max} \geq 40 \text{ pF}$ $R_{\text{ins}}: \geq 10000 \text{ M}\Omega$; rotor contact R: $\leq 10 \text{ m}\Omega$ voltage proof: 500 V for 1 minute visual examination: no mechanical damage operating torque: 1 to 15 mNm for $C_{\max} < 33 \text{ pF}$; 1 to 25 mNm for $C_{\max} \geq 33 \text{ pF}$
29		mechanical endurance	10 cycles	$\Delta C/C: \leq 1.5\%$ $\Delta C/C$ after axial thrust: $\leq 0.3\%$; rotor contact R: $\leq 10 \text{ m}\Omega$ voltage proof: 500 V for 1 minute visual examination: no mechanical damage operating torque: 1 to 15 mNm for $C_{\max} < 33 \text{ pF}$; 1 to 25 mNm for $C_{\max} \geq 33 \text{ pF}$