

## Film dielectric trimmers

2222 808 .....  
 Ø5 mm

### FEATURES

- Housing diameter 5 mm
- Top and bottom or top adjustment
- Round or hexagonal head
- Vertical version.

### APPLICATIONS

- For consumer and industrial equipment.

### DESCRIPTION

The vanes of the trimmer are stacked on a sturdy plastic base. The colour of the base indicates the maximum capacitance (see Tables 4, 5 and 6). The dielectric is a film of polypropylene (PP) or polytetrafluorethylene (PTFE) for the standard versions and polycarbonate (PC) for the economic and hexagonal head versions. The dielectric supports the vanes in such a way that good stability is ensured and no microphony can occur.

Flux absorption between the vanes is prevented.

Cleaning with solvents is not advised.

For outline drawings and dimensions see Figs 1 and 2.

### QUALITY LEVEL

Sampling and data evaluation for quality level in accordance with "MIL-STD-105D" and "IEC 60410":

<0.15% major defects

<0.65% minor defects.

Each capacitor is tested for minimum  $C_{max}$  and is also subjected to the full test voltage.

### QUICK REFERENCE DATA

DESCRIPTION	VALUE
$C_{min}/C_{max}$	0.35/1.5 to 4/27 pF
Rated voltage (DC)	150 V
Test voltage (DC) for 1 minute	300 V
Maximum contact resistance	10 mΩ
Minimum insulation resistance	10000 MΩ
Tan δ at $C_{max}$ , 1 MHz:	
PC	$\leq 70 \times 10^{-4}$
PP, PTFE	$\leq 10 \times 10^{-4}$
Category temperature range:	
PP	-40 to +70 °C
PC, PTFE	-40 to +85 °C
Climatic category (IEC 60068):	
PP	40/070/21
PC, PTFE	40/085/21
Minimum storage temperature	-55 °C
Related specification	IEC 60418-1 and 4

### MECHANICAL DATA

DESCRIPTION	VALUE
Effective angle of rotation	180°
Operating torque:	
$C_{max} < 20$ pF	1 to 15 mNm
$C_{max} \geq 20$ pF	1 to 25 mNm
Maximum axial thrust	2 N

Film dielectric trimmers

2222 808 .....  
 Ø5 mm

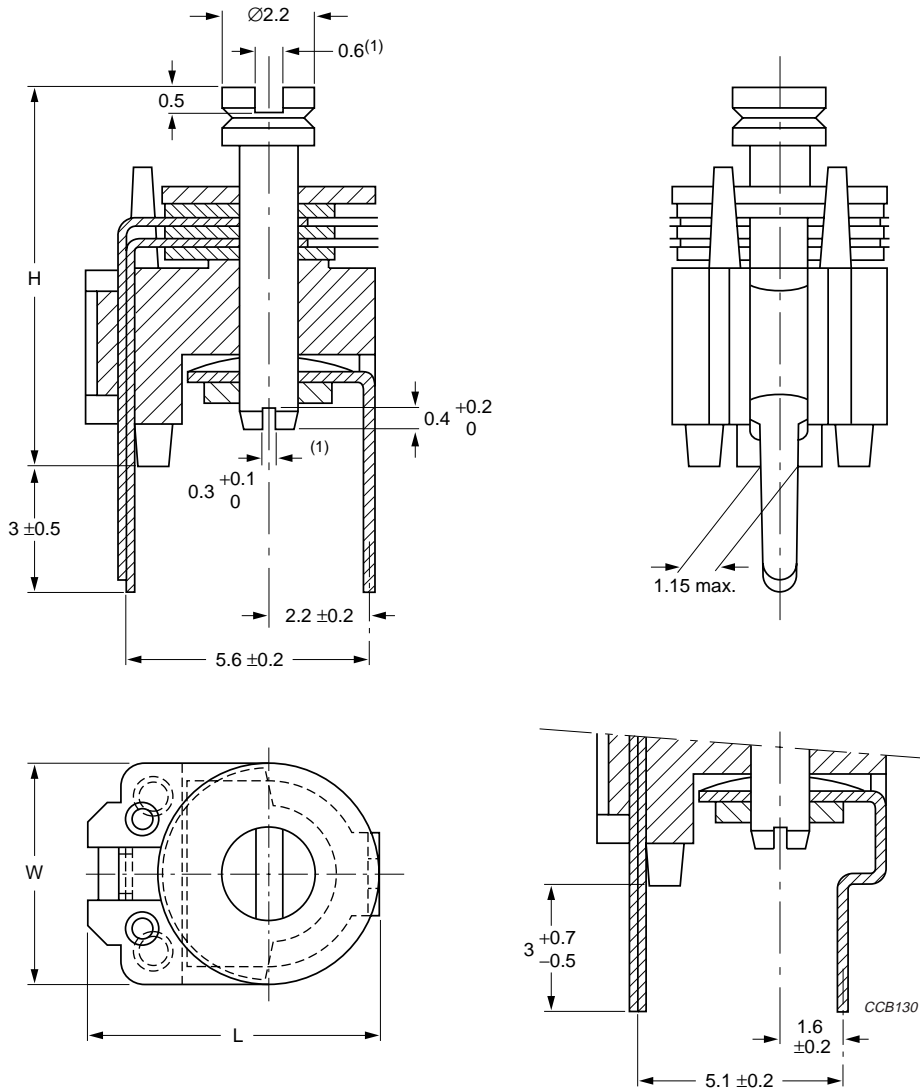

a. Dimensional outlines.

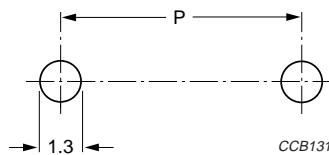

b. Hole pattern.

Dimensions in mm.

For dimensions H, W and L, see Tables 1 and 2.

For dimension P, see Table 3.

(1) The position of the shaft is not relative to the position of the vanes.

Fig.1 Trimmers 2222 808 ..... series, with round head.

Film dielectric trimmers

2222 808 .....

Ø5 mm

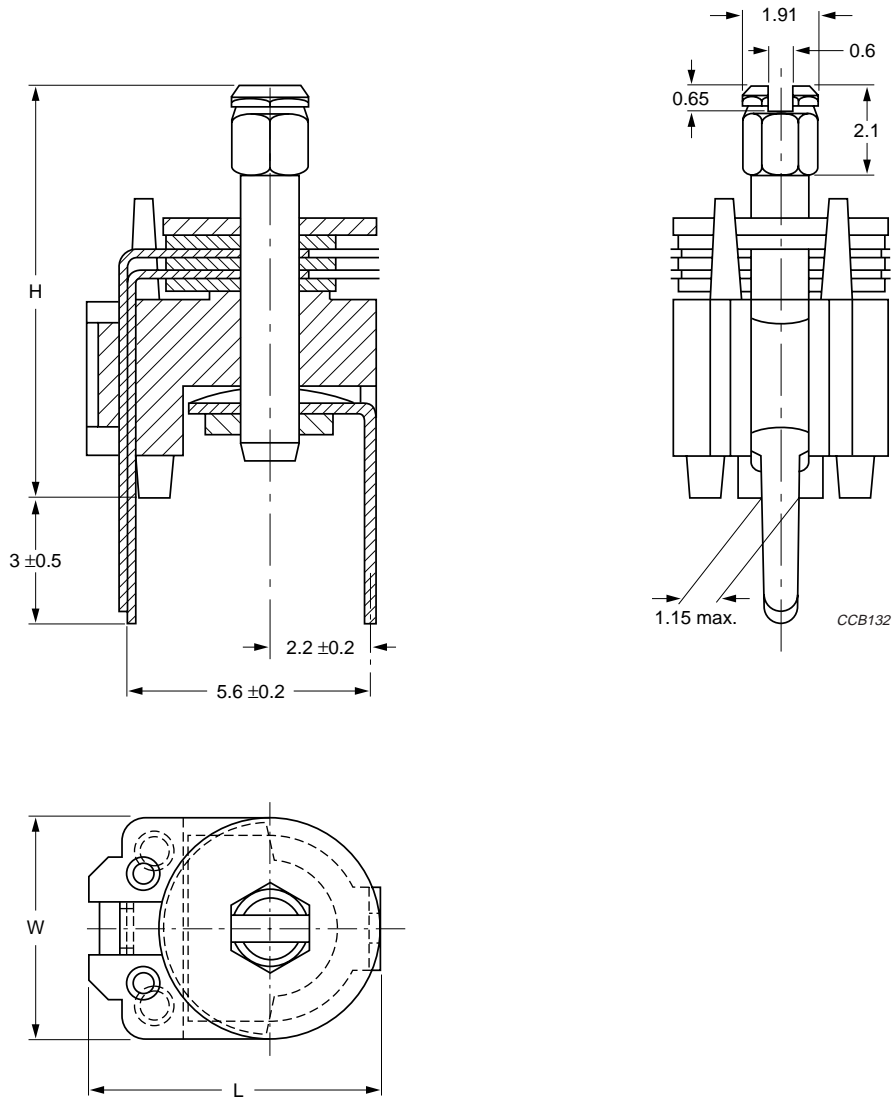

a. Dimensional outlines.

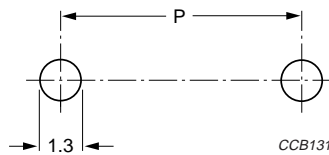

b. Hole pattern.

Dimensions in mm.

For dimensions H, W and L, see Table 2.

For dimension P, see Table 3.

Fig.2 Trimmers 2222 808 .....

## Film dielectric trimmers

2222 808 .....  
Ø5 mm**Table 1** Standard versions; capacitance and relevant physical dimensions; see Fig.1

$C_{\min}/C_{\max}$ (pF)	$H_{\max}$ (mm)	$W_{\max}$ (mm)	$L_{\max}$ (mm)
0.35/1.5	7.0	5.5	7.3
1.5/5	7.0	5.5	7.3
3/10	7.0	5.5	7.3
3/15	8.8	5.5	7.3
4/20	8.8	5.5	7.3
4/27	9.0	6.2	7.8

**Table 2** Hexagonal and economic versions; relevant physical dimensions; see Fig.2

TYPE OF HEAD	$H_{\max}$ (mm)	$W_{\max}$ (mm)	$L_{\max}$ (mm)
Hexagonal	9.7	5.5	7.3
Round	7.7	5.5	7.3

**MOUNTING**

The trimmer has a lead pitch of 5.08 mm or 5.6 mm and can be mounted on printed-circuit boards with a minimum hole diameter of 1.25 mm.

**PACKAGING**

Bulk packaged in cardboard boxes lined with expanded plastic, 1000 units per box.

## Film dielectric trimmers

2222 808 .....  
Ø5 mm

## ORDERING INFORMATION

Table 3 Selection chart; see Figs 1 and 2

$C_{\min}/C_{\max}$ (pF)	CATALOGUE NUMBER 2222 808 .....		
	TOP AND BOTTOM ADJUSTMENT (P = 5.6 mm)	TOP ADJUSTMENT ONLY (P = 5.6 mm)	TOP ADJUSTMENT ONLY (P = 5.08 mm)
<b>Standard versions: polytetrafluorethylene, round head</b>			
0.35/1.5	22158	–	–
<b>Standard versions: polypropylene, round head</b>			
1.5/5	23508	–	20508
3/10	23109	–	20109
3/15	23159	–	20159
4/20	23209	–	20209
4/27	23279	–	20279
<b>Economic versions: polycarbonate, round head</b>			
1.5/7	–	20126	–
1.6/15	–	20127	–
3/20	–	20123	–
3.5/27	–	20128	–
<b>Economic versions: polycarbonate, hexagonal head</b>			
1.5/7	–	21708	–
1.6/15	–	21159	–
3/20	–	21209	–
3.5/27	–	21279	–

## Film dielectric trimmers

2222 808 .....  
Ø5 mm

## ELECTRICAL DATA

Table 4 Standard versions with round head

GUARANTEED MAX. $C_{min}$ / MIN. $C_{max}$ at 200 kHz (pF)	$\tan \delta$ at $C_{max} \times 10^{-4}$		TEMP. COEFF. <sup>(1)</sup> ( $10^{-6}/K$ )	MIN. $f_{res}$ at $C_{max}$ (MHz)	COLOUR OF BASE	SMALLEST PACKAGING QUANTITY	CATALOGUE NUMBER
	1 MHz	100 MHz					
0.35/1.5	$\leq 10$	–	$-450 \pm 550$	–	–	1000	2222 808 22158
1.5/5	$\leq 10$	$\leq 25$	$-200 \pm 550$	700	grey	1000	2222 808 20508
							2222 808 23508
3/10	$\leq 10$	$\leq 25$	$-250 \pm 550$	500	yellow	1000	2222 808 20109
							2222 808 23109
3/15	$\leq 10$	$\leq 25$	$-250 \pm 550$	400	blue	1000	2222 808 20159
							2222 808 23159
4/20	$\leq 10$	$\leq 25$	$-250 \pm 400$	300	green	1000	2222 808 20209
							2222 808 23209
4/27	$\leq 10$	$\leq 25$	$-250 \pm 400$	300	red	1000	2222 808 20279
							2222 808 23279

## Note

1.  $C$ : 60% to 80% of  $C_{max}$ ;  $T_{amb}$ : from +20 °C to +70 °C.

Table 5 Economic versions with round head

REFERENCE $C_{min}/C_{max}$ (pF)	$\tan \delta$ at $C_{max} \times 10^{-4}$ (1 MHz)	TEMP. COEFF. ( $10^{-6}/K$ )	COLOUR OF BASE	SMALLEST PACKAGING QUANTITY	CATALOGUE NUMBER
1.5/7	$\leq 70$	$-50 \pm 550$	grey	1000	2222 808 20126
1.6/15	$\leq 70$	$-50 \pm 550$	blue	1000	2222 808 20127
3/20	$\leq 70$	$-50 \pm 550$	green	1000	2222 808 20123
3.5/27	$\leq 70$	$-100 \pm 400$	red	1000	2222 808 20128

Table 6 Versions with hexagonal head

REFERENCE $C_{min}/C_{max}$ (pF)	$\tan \delta$ at $C_{max} \times 10^{-4}$ (1 MHz)	TEMP. COEFF. ( $10^{-6}/K$ )	COLOUR OF BASE	SMALLEST PACKAGING QUANTITY	CATALOGUE NUMBER
1.5/7	$\leq 70$	$-50 \pm 550$	grey	1000	2222 808 21708
1.6/15	$\leq 70$	$-50 \pm 550$	blue	1000	2222 808 21159
3/20	$\leq 70$	$-50 \pm 550$	green	1000	2222 808 21209
3.5/27	$\leq 70$	$-100 \pm 400$	red	1000	2222 808 21279

## Film dielectric trimmers

2222 808 .....  
Ø5 mm

## TESTS AND REQUIREMENTS

Table 7 Test procedures and requirements

IEC 60418-1 CLAUSE	IEC 60068 TEST METHOD	TEST	PROCEDURE	REQUIREMENTS
4.2		method of mounting	method A	
14		capacitance drift	after TC measurement	$\Delta C/C: \leq 3\%$ for $C_{\max} \leq 10$ pF $\Delta C/C: \leq 2\%$ for $C_{\max} > 10$ pF
19		thrust	axial thrust of 2 N	$\Delta C/C: \leq 0.4\%$
21		robustness of terminations:		
21.1	Ua	tensile	1 N	no damage
21.2	Ub	bending	1 cycle	no damage
22	Na	rapid change of temperature	1 cycle; 0.5 hours at lower and 0.5 hours at upper category temperature	$\Delta C/C: \leq 2.5\%$
23	T	soldering:		
	Ta	solderability	solder bath immersion 3 mm; 235 °C; 2 s	good wetting no mechanical damage
	Tb	resistance to heat	solder bath: 260 °C; 10 s	no mechanical damage
24	Eb	impact bump	4000 ±10 bumps; 40 g; 6 ms	$\Delta C/C: \leq 1\%$ ; no mechanical damage
25	Fc	vibration	frequency 10 to 55 Hz; amplitude 0.75 mm; 1.5 hours	$\Delta C/C: \leq 1\%$ ; no mechanical damage
26		climatic sequence:		
26.1	B	dry heat	16 hours at upper category temperature	$\Delta C/C: \leq 4\%$ tan $\delta$ for PP and PTFE foil: $\leq 15 \times 10^{-4}$ tan $\delta$ for PC foil: $\leq 80 \times 10^{-4}$ $R_{\text{ins.}}: \geq 10000$ M $\Omega$ rotor contact R: $\leq 10$ m $\Omega$
26.2	D	damp heat accelerated, first cycle	1 cycle; 24 hours; +40 °C; 95 to 100% RH	voltage proof: 300 V for 1 minute
26.3	Aa	cold	16 hours; -40 °C	visual examination: no mechanical damage
26.5		damp heat accelerated, remaining cycles	1 cycle; 24 hours; +40 °C; 95 to 100% RH	operating torque: 1 to 20 mNm for $C_{\max} < 20$ pF; 1 to 30 mNm for $C_{\max} \geq 20$ pF

## Film dielectric trimmers

2222 808 .....

Ø5 mm

IEC 60418-1 CLAUSE	IEC 60068 TEST METHOD	TEST	PROCEDURE	REQUIREMENTS
27	Ca	damp heat steady state	21 days; +40 °C; 90 to 95% RH	$\Delta C/C: \leq 3\%$ tan $\delta$ for PP and PTFE foil: $\leq 15 \times 10^{-4}$ ; tan $\delta$ for PC foil: $\leq 80 \times 10^{-4}$ $R_{ins}: \geq 10000 \text{ M}\Omega$ ; rotor contact R: $\leq 10 \text{ m}\Omega$ voltage proof: 300 V for 1 minute visual examination: no mechanical damage operating torque: 1 to 20 mNm for $C_{max} < 20 \text{ pF}$ ; 1 to 30 mNm for $C_{max} \geq 20 \text{ pF}$
29		mechanical endurance	10 cycles	$\Delta C/C: \leq 3\%$ $\Delta C/C$ after axial thrust: $\leq 0.3\%$ ; rotor contact R: $\leq 10 \text{ m}\Omega$ voltage proof: 300 V for 1 minute visual examination: no mechanical damage operating torque: 0.5 to 22.5 mNm for $C_{max} < 20 \text{ pF}$ ; 0.5 to 30 mNm for $C_{max} \geq 20 \text{ pF}$