

Coaxial

Power Splitter/Combiner

2 Way-0° 50Ω 5 to 500 MHz

ZFSC-2-1+
ZFSC-2-1



BNC version shown
CASE STYLE: K18

Maximum Ratings

Operating Temperature	-55°C to 100°C
Storage Temperature	-55°C to 100°C
Power Input (as a splitter)	1W max.
Internal Dissipation	0.125W max.

Coaxial Connections

SUM PORT	3
PORT 1	1
PORT 2	2

Features

- wideband, 5 to 500 MHz
- low insertion loss, 0.3 dB typ.
- excellent isolation, 28 dB typ.
- excellent amplitude unbalance, 0.1 dB typ.
- good VSWR, 1.2:1 typ.
- rugged shielded case

Applications

- VHF/UHF
- instrumentation
- communication systems

Connectors	Model
BNC	ZFSC-2-1(+)
SMA	ZFSC-2-1-S+
N-TYPE	ZFSC-2-1-N(+)
BRACKET (OPTION "B")	

+ RoHS (OPTIONAL in accordance with EU Directive (2002/95/EC))

The +Suffix identifies RoHS Compliance. See our web site for RoHS Compliance methodologies and qualifications.

Outline Drawing

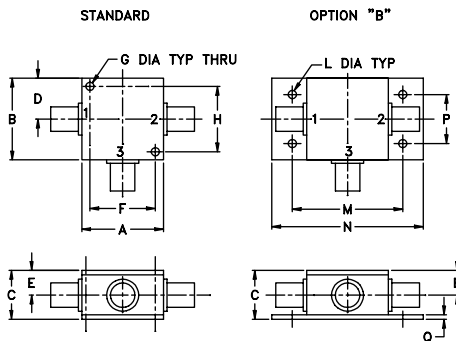

Outline Dimensions (inch/mm)

A	B	C	D	E	F	G	H
1.25	1.25	.75	.63	.38	1.00	.125	1.000
31.75	31.75	19.05	16.00	9.65	25.40	3.18	25.40

J	K	L	M	N	P	Q	wt
--	--	.125	1.688	2.18	.75	.07	grams
--	--	3.18	42.88	55.37	19.05	1.78	70.0

For option B with N-type connectors, dimension "C" increases to 0.94 inches.

Splitter Electrical Specifications

FREQ. RANGE (MHz)	ISOLATION (dB)						INSERTION LOSS (dB) ABOVE 3.0 dB						PHASE UNBALANCE (Degrees)			AMPLITUDE UNBALANCE (dB)		
	L		M		U		L		M		U		L	M	U	L	M	U
	Typ.	Min	Typ.	Min	Typ.	Min	Typ.	Max.	Typ.	Max.	Typ.	Max.	Max.	Max.	Max.	Max.	Max.	Max.
f _L -f _U	30	25	28	20	25	20	0.2	0.5	0.3	0.6	0.6	0.8	2	4	4	0.15	0.15	0.30

L = low range [f_L to 10 f_L] M = mid range [10 f_L to f_U/2] U = upper range [f_U/2 to f_U]

Typical Performance Data

Frequency (MHz)	Insertion Loss (dB)		Amplitude Unbalance (dB)	Isolation (dB)	Phase Unbalance (deg.)	VSWR S	VSWR 1	VSWR 2
	S-1	S-2						
20	3.17	3.17	0.00	38.54	0.08	1.02	1.05	1.05
35	3.18	3.19	0.00	37.55	0.05	1.03	1.04	1.05
80	3.23	3.23	0.00	35.20	0.01	1.05	1.05	1.05
140	3.27	3.28	0.01	32.86	0.01	1.07	1.06	1.06
170	3.29	3.30	0.01	31.68	0.03	1.09	1.06	1.06
200	3.31	3.32	0.01	30.89	0.05	1.10	1.07	1.07
225	3.33	3.34	0.02	30.37	0.09	1.11	1.07	1.07
250	3.33	3.35	0.02	29.60	0.08	1.12	1.08	1.08
290	3.35	3.38	0.03	28.75	0.13	1.14	1.09	1.09
330	3.38	3.41	0.03	28.01	0.17	1.15	1.09	1.10
370	3.39	3.43	0.04	27.35	0.21	1.17	1.10	1.11
410	3.41	3.46	0.05	26.80	0.25	1.19	1.11	1.12
450	3.43	3.48	0.05	26.31	0.30	1.21	1.12	1.13
475	3.44	3.50	0.06	26.09	0.32	1.22	1.13	1.14
500	3.46	3.52	0.06	25.83	0.34	1.23	1.13	1.14

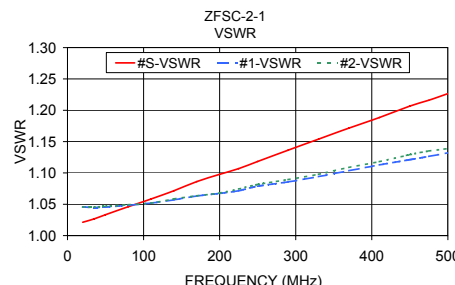
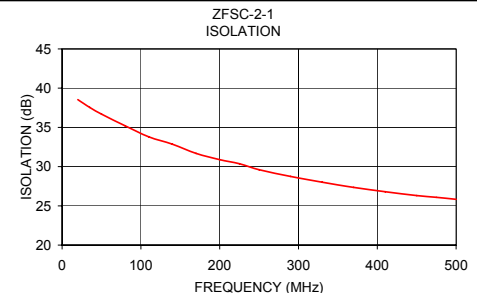
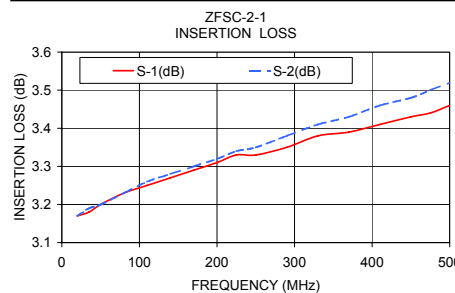

electrical schematic

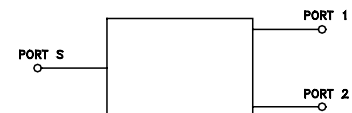

Mini-Circuits
ISO 9001 ISO 14001 CERTIFIED

ALL NEW
minicircuits.com

P.O. Box 350166, Brooklyn, New York 11235-0003 (718) 934-4500 Fax (718) 332-4661 For detailed performance specs & shopping online see Mini-Circuits web site



The Design Engineers Search Engine Provides ACTUAL Data Instantly From MINI-CIRCUITS At: www.minicircuits.com

RF/IF MICROWAVE COMPONENTS

REV. B
M108294
ZFSC-2-1
HY/TD/CP
070604