

**MC3367**

**LOW VOLTAGE  
 SINGLE CONVERSION  
 FM RECEIVER**

**SILICON MONOLITHIC  
 INTEGRATED CIRCUIT**

**LOW VOLTAGE FM NARROWBAND RECEIVER**

... with single conversion circuitry including oscillator, mixer, IF amplifiers, limiting IF circuitry, and quadrature discriminator. The MC3367 is perfect for narrowband audio and data applications up to 75 MHz which require extremely low power consumption. Battery powered applications down to  $V_{CC} = 1.1$  V are possible. The MC3367 also includes an on-board voltage regulator, low battery detection circuitry, a receiver enable allowing a power down "sleep mode," two undedicated buffer amplifiers to allow simultaneous audio and data reception, and a comparator for enhancing FSK (Frequency Shift Keyed) data reception to 1200 baud.

- Low Supply Voltage:  $V_{CC} = 1.1$  to 3.0 Vdc
- Low Power Consumption:  $P_D = 1.5$  to 5.0 mW
- Input Bandwidth 75 MHz
- Excellent Sensitivity: Input Limiting Voltage for 12 dB  $S_{inad} = 0.5 \mu V_{rms}$  from Conjugated Matched Source
- Voltage Regulator Available (Source Capability 3.0 mA)
- Receiver Enable to Allow Active/Standby Operation
- Low Battery Detection Circuitry
- Self Biasing Audio Buffer with Nominal Gain  $A_V = 4.0$
- Data Buffer with Nominal Gain  $A_V = 3.2$
- FSK Data Shaping Comparator Included
- Standard 28-Lead Surface Mount (SOIC) Package

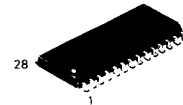

**DW SUFFIX**  
 PLASTIC PACKAGE  
 CASE 751F  
 (SO-28L)

**PIN CONNECTIONS**

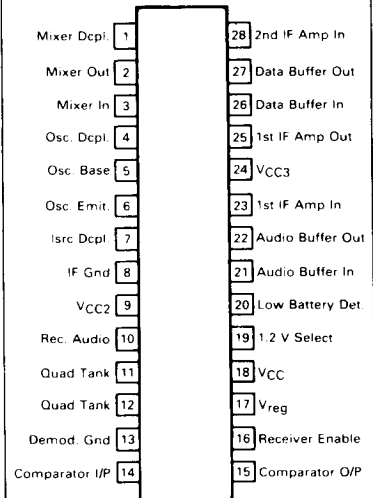

**FIGURE 1 — BLOCK DIAGRAM**

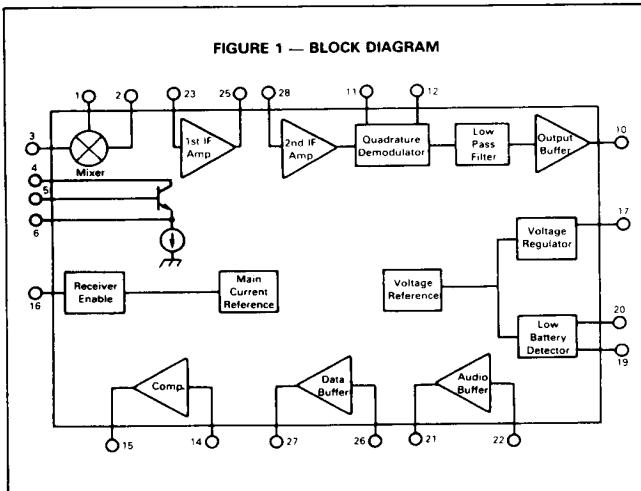

# MC3367

## MAXIMUM RATINGS (Voltages with respect to Pins 8 and 13; $T_A = 25^\circ\text{C}$ )

Rating	Pin	Value	Unit
Supply Voltage	18	5.0	Vdc
RF Input Signal	3	1.0	Vrms
Audio Buffer Input	21	1.0	Vrms
Data Buffer Input	26	1.0	Vrms
Comparator Input	14	1.0	Vrms
Junction Temperature	—	150	$^\circ\text{C}$
Storage Temperature	—	-65 to +150	$^\circ\text{C}$

Devices should not be operated at or outside these values. The "Recommended Operating Limits" provide for actual device operation.

## RECOMMENDED OPERATING CONDITIONS

Parameter	Pin	Value	Unit
Supply Voltage	18	1.1 to 3.0	Vdc
Receiver Enable Voltage	16	0 or $V_{CC}$	Vdc
1.2 V Select Voltage	19	Open or $V_{CC}$	Vdc
RF Input Signal Level	3	0.001 to 100	mVrms
RF Input Frequency	3	0 to 75	MHz
Intermediate Frequency (IF)	—	455	kHz
Audio Buffer Input	21	0 to 75	mVrms
Data Buffer Input	26	0 to 75	mVrms
Comparator Input	14	10 to 300	mVrms
Ambient Temperature	—	0 to 70	$^\circ\text{C}$

## ELECTRICAL CHARACTERISTICS ( $V_{CC} = 1.3\text{ V}$ , $f_o = 10.7\text{ MHz}$ , $f_{mod} = 1.0\text{ kHz}$ , Deviation = 3.0 kHz, $T_A = 25^\circ\text{C}$ , Test Circuit of Figure 2 unless otherwise noted)

Characteristic	Pin	Min	Typ	Max	Units
----------------	-----	-----	-----	-----	-------

### OVERALL MC3367 PERFORMANCE

Drain Current — Pin 15 = $V_{CC}$	—	—	1.4	3.0	mA
— Pin 15 = 0 Vdc	—	—	0.5	—	$\mu\text{A}$
Recovered Audio (RF Input = 10 mV)	10	—	13	—	mVrms
Noise Output (RF Input = 0 mV)	10	—	4.5	—	mVrms
Input for -3.0 dB Limiting	3	—	0.2	—	$\mu\text{Vrms}$

### MIXER

Mixer Input Resistance ( $R_p$ )	3	—	3.0	—	k $\Omega$
Mixer Input Capacitance ( $C_p$ )	3	—	9.0	—	pF

### FIRST IF AMPLIFIER

First IF Amp Voltage Gain	—	—	25	—	dB
---------------------------	---	---	----	---	----

### AUDIO BUFFER

Voltage Gain	—	—	4.0	—	V/V
Input Resistance	21	—	125	—	k $\Omega$
Maximum Input for Undistorted Output	21	—	70	—	mVrms
Maximum Output Swing	22	—	800	—	mVpp
Output Resistance	22	—	680	—	$\Omega$

### DATA BUFFER

Voltage Gain	—	—	3.2	—	V/V
Input Resistance	26	—	8.0	—	M $\Omega$
Maximum Input for Undistorted Output (< 3% THD)	26	—	70	—	mVrms
Maximum Output Swing	27	—	600	—	mVpp
Output Resistance	27	—	1.5	—	k $\Omega$

(continued)

# MC3367

**ELECTRICAL CHARACTERISTICS — continued** ( $V_{CC} = 1.3 \text{ V}$ ,  $f_o = 10.7 \text{ MHz}$ ,  $f_{mod} = 1.0 \text{ kHz}$ , Deviation =  $3.0 \text{ kHz}$ ,  
 $T_A = 25^\circ\text{C}$ , Test Circuit of Figure 2 unless otherwise noted)

Characteristic	Pin	Min	Typ	Max	Units
<b>COMPARATOR</b>					
Minimum Input for Triggering	14	—	7.0	—	mVrms
Maximum Input Frequency ( $R_L = 100 \text{ k}\Omega$ )	14	—	25	—	kHZ
Rise Time (10–90%; $R_L = 100 \text{ k}\Omega$ )	15	—	5.0	—	$\mu\text{s}$
Fall Time (90–10%; $R_L = 100 \text{ k}\Omega$ )	15	—	0.4	—	$\mu\text{s}$
<b>LOW BATTERY DETECTOR</b>					
Low Battery Trip Point	18	—	1.09	—	Vdc
Low Battery Output — $V_{CC} = 0.9 \text{ V}$	20	—	0.2	—	Vdc
— $V_{CC} = 1.3 \text{ V}$	20	—	$V_{CC}$	—	Vdc
<b>VOLTAGE REGULATOR</b>					
Regulated Output (see Figure 6)	17	—	0.95	—	Vdc
Source Capability	17	—	—	3.0	mA

FIGURE 2 — EVALUATION CIRCUIT

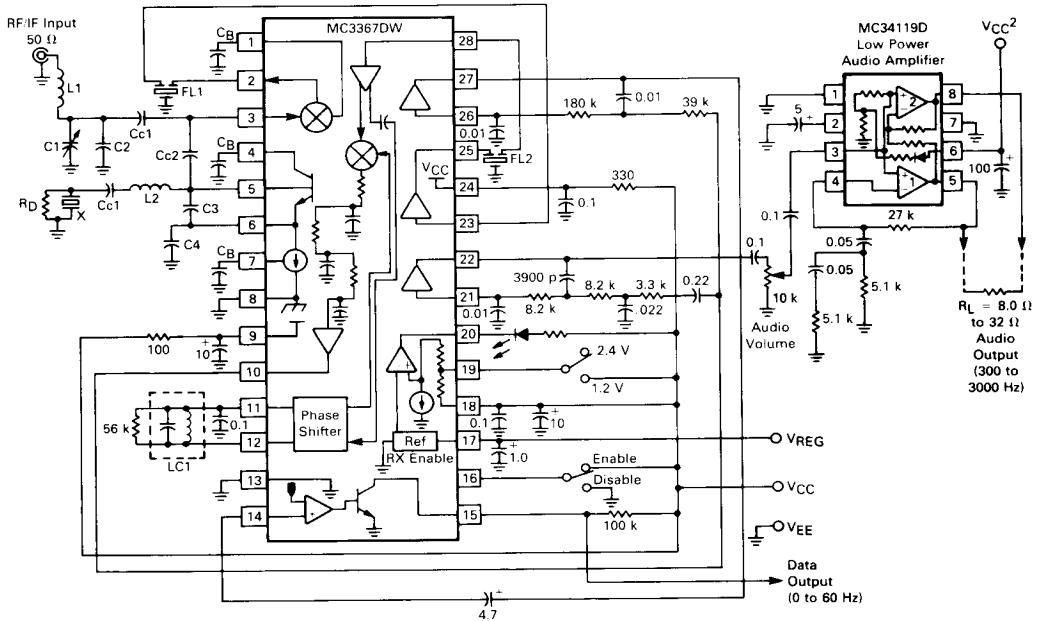

**NOTES:**

- FL1 and FL2 are 455 kHz ceramic bandpass filters, which should have input and output impedances of 1.5 k $\Omega$  to 2.0 k $\Omega$ . Suggested part numbers are muRata CFU455X or CFW455X — the "X" suffix denotes bandwidth.
- LC1 is a 455 kHz resonator. Recommended part number are Toko America 7M8128Z. The evaluation board layout shown provides for use of either resonator. **Ceramic discriminator elements cannot be used with the MC3367 due to their low input impedance.** The damping resistor value can be raised to increase the recovered audio or lowered to increase the quadrature detector's bandwidth and linearity — practical limits are approximately 27 k $\Omega$  to 75 k $\Omega$ . Typically the quadrature detector's bandwidth should match the low IF filter's bandwidth.
- The data buffer is set up as a low-pass filter with a corner frequency of approximately 200 Hz. The audio buffer is a bandpass filter with corner frequencies of 300 Hz and 3.0 kHz. The audio amplifier provides bass suppression.
- Cc1 and Cc3 are RF coupling capacitors and should have  $\leq 20 \Omega$  impedance at the desired input and oscillator frequencies.
- Cc2 provides "light coupling" of the oscillator signal into the mixer, and should have a  $\approx 3.0 \text{ k}\Omega$  to  $5.0 \text{ k}\Omega$  impedance at the desired local oscillator frequency.
- Capacitors labelled C<sub>B</sub> are bypass capacitors and should have  $\leq 20 \Omega$  impedance at the desired RF and local oscillator frequencies.
- The network of L1, C1 and C2 provides impedance matching of the mixer input (nominally 3.0 k $\Omega$  shunted by 9.0 pF) to 50  $\Omega$  at the desired RF/IF input frequency. This will allow for bench testing of the receiver from typical RF signal generators or radio service monitors, but additional or different matching will be required to maximize receiver sensitivity when used in conjunction with an antenna, RF preamplifier or mixer.

FIGURE 3 — RECOVERED AUDIO versus SUPPLY

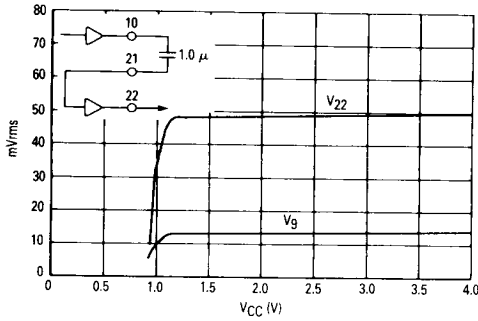

FIGURE 4 — DRAIN versus SUPPLY

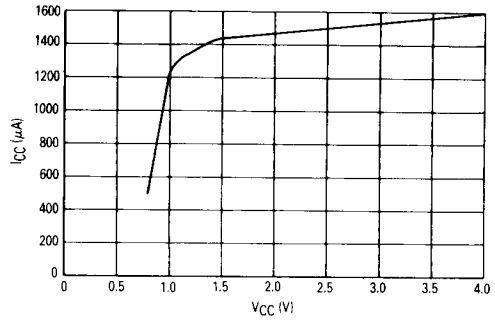

FIGURE 5 — S + N, N versus INPUT

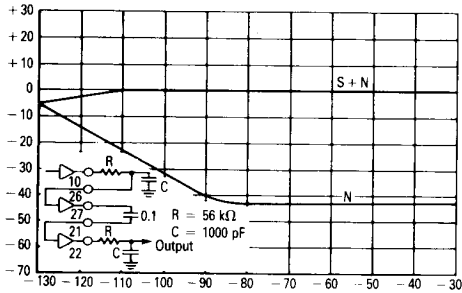

FIGURE 6 — VREG versus SUPPLY

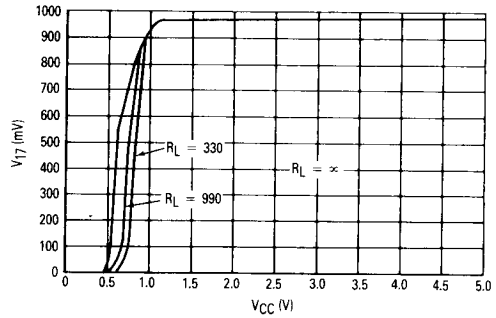

FIGURE 7 — REGULATED OUTPUT AND RECOVERED AUDIO versus TEMPERATURE

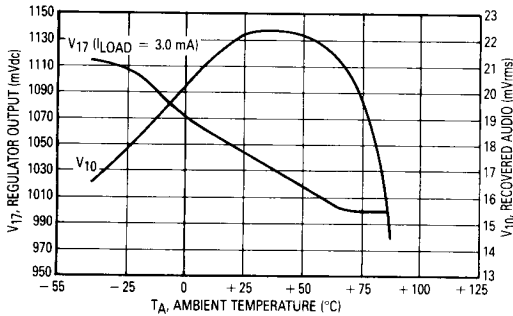
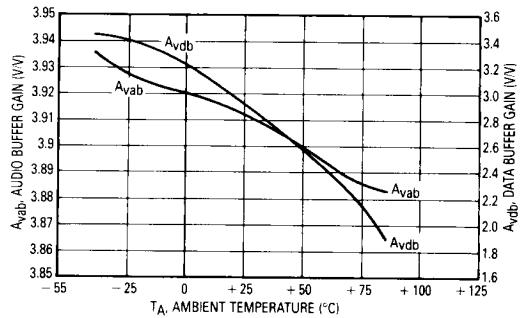

FIGURE 8 — BUFFER AMPLIFIER GAINS versus TEMPERATURE



# MC3367

FIGURE 9 — CURRENT DRAIN versus TEMPERATURE

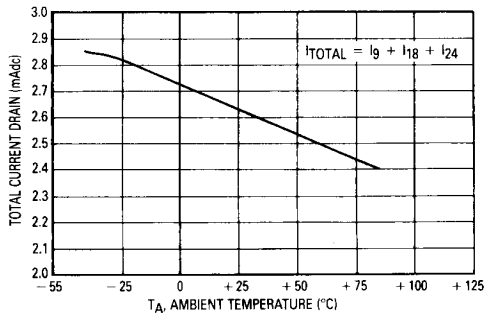
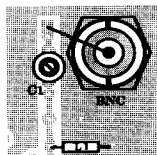
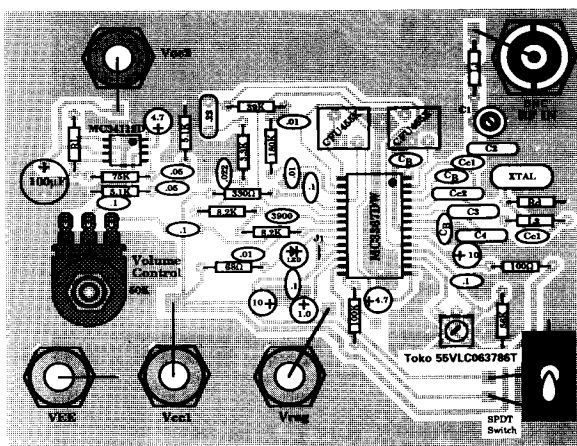

FIGURE 10 — MC3367DW DEMONSTRATION RECEIVER



Alternate input circuit for 72 MHz receiver.

In. Freq.	L1	L2	C1	C2	C3	C4	Ce1	Ce2	C <sub>B</sub>	R <sub>D</sub>
10.7 MHz	6.8 μH	Short	2-82 pF	10 pF	120 pF	50 pF	1.0 k pF	5.0 pF	0.1 μF	Open
45 MHz	0.68 μH	1.2 μH	5-25 pF	Open	30 pF	5.0 pF	1.0 k pF	1.0 pF	1.0 k pF	1.0 k
72 MHz	0.22 μH	0.22 μH	5-25 pF	Open	18 pF	3.0 pF	470 pF	1.0 pF	470 pF	1.0 k

Volume Control: CRL B12503SL

V<sub>CC1</sub>: 1.1 V to 3.0 V

V<sub>CC2</sub>: 2.0 V to 16 V

Speaker: 8.0 Ω to 32 Ω

J1: Jumper — install for 1.2 V operation. Leave open for 2.4 V operation.

ICs mount on circuit side (back) of PC board.

C3, C4 must be 5% silver mica

# MC3367

FIGURE 11 — BOTTOM (CIRCUIT) SIDE

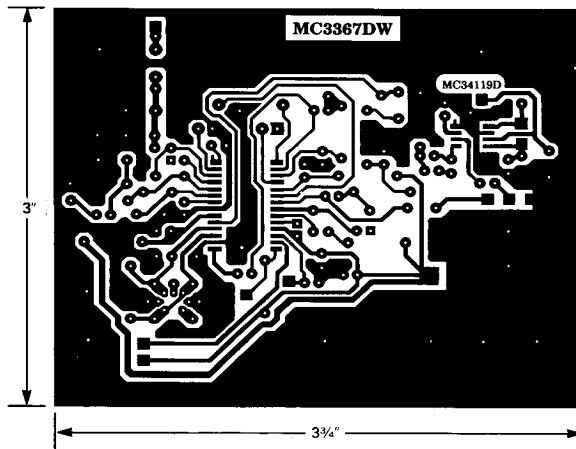

FIGURE 12 — TOP (COMPONENT/GROUND PLANE) SIDE

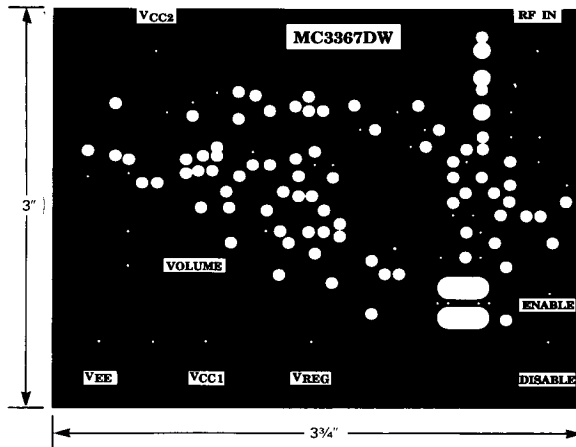
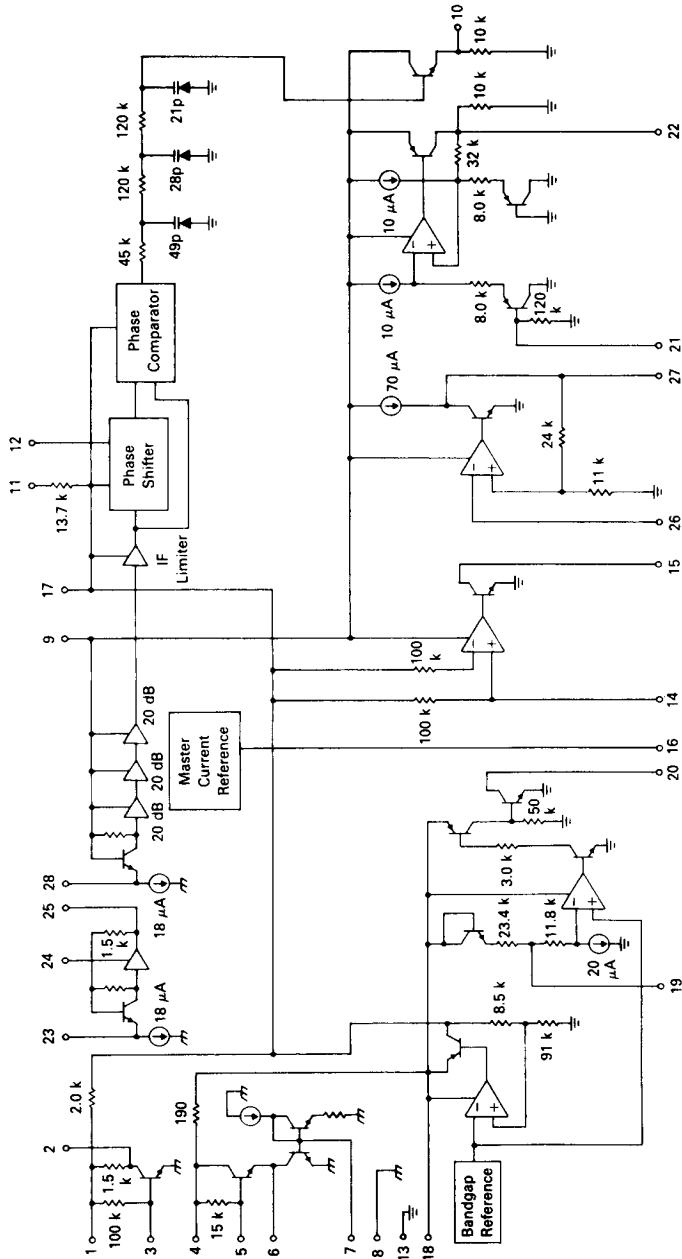

FIGURE 13 — CIRCUIT SCHEMATIC



**CIRCUIT DESCRIPTION**

The MC3367 is an FM narrowband receiver capable of operation to 75 MHz. The low voltage design yields low power drain and excellent sensitivity in narrowband voice and data link applications. In the typical application the mixer amplifies the incoming RF or IF signal and converts this frequency to 455 kHz. The signal is then filtered by a 455 kHz ceramic filter and applied to the first intermediate frequency (IF) amplifier input, before passing through a second ceramic filter. The modulated IF signal is then applied to the limiting IF amplifier and detector circuitry. Modulation is recovered by a conventional quadrature detector. The typical modulation bandwidth available is 3.0 to 5.0 kHz.

Features available include buffers for audio/data amplification and active filtering, on board voltage regulator, low battery detection circuitry with programmable level, and receiver disable circuitry. The MC3367 is an FM utility receiver to be used for voice and/or narrowband data reception. It is especially suitable where extremely low power consumption and high design flexibility are required.

**APPLICATION**

The MC3367 can be used as a high performance FM IF for use in low power dual conversion receivers. Because of the MC3367's extremely good sensitivity (0.6  $\mu$ V for 20 dB (S + N)/N, see Figure 5), it can also be used as a stand alone single conversion narrowband receiver to 75 MHz for applications not sensitive to image frequency interference. An RF preamplifier will likely be needed to overcome preselector losses.

The oscillator is a Colpits type which must be run under crystal control. For fundamental mode crystals choose resonators, parallel resonant, for a 32 pF load. For higher frequencies, use a 3rd overtone series mode type. The coil (L2) and R<sub>D</sub> resistor are needed to ensure proper operation.

The best adjacent channel and sensitivity response occur when two 455 kHz ceramic filters are used, as shown in Figure 2. Either can be replaced by a 0.1  $\mu$ F coupling capacitor to reduce cost, but some degradation in sensitivity and/or stability is suspected.

The detector is a quadrature type, with the connection from the limiter output to the detector input provided internally as with the MC3359 and the MC3361. A 455 kHz LC tank circuit must be provided externally. One of the tank pins (Pin 11) must be decoupled using a 0.1  $\mu$ F capacitor. The 56 k $\Omega$  damping resistor (see Figure 2), determines the peak separation of the detector (and thus its bandwidth). Smaller values will increase the separation and bandwidth but decrease recovered audio and sensitivity.

The data buffer is a noninverting amplifier with a nominal voltage gain of 3.2 V/V. This buffer needs its dc bias (approx. 250 mV) provided externally or else debiasing will occur. A single-pole RC filter, as shown in Figure 5, connecting the recovered audio output to the data buffer input provides the necessary dc bias and some post detection filtering. The buffer can also be used as an active filter.

The audio buffer is a noninverting amplifier with a nominal voltage gain of 4.0 V/V. This buffer is self-biasing so its input should be ac coupled. The two buffers, when applied as active filters, can be used together to allow simultaneous audio and very low speed data reception. Another possible configuration is to receive audio only and include a noise-triggered squelch.

The comparator is a noninverting type with an open collector output. Typically, the pull-up resistor used between Pin 15 and V<sub>CC</sub> is 100 k $\Omega$ . With R<sub>L</sub> = 100 k $\Omega$  the comparator is capable of operation up to 25 kHz. This circuit is self-biasing, so its input should be ac coupled.

The regulator is a 0.95 V reference capable of sourcing 3.0 mA. This pin (Pin 17) needs to be decoupled using a 1.0–10  $\mu$ F capacitor to maintain stability of the MC3367.

All three V<sub>CC</sub>s on the MC3367 (V<sub>CC</sub>, V<sub>CC2</sub>, V<sub>CC3</sub>) run on the same supply voltage. V<sub>CC</sub> is typically decoupled using capacitors only. V<sub>CC2</sub> and V<sub>CC3</sub> should be bypassed using the RC bypasses shown in Figure 2. Eliminating the resistors on the V<sub>CC2</sub> and V<sub>CC3</sub> bypasses may be possible in some applications, but a reduction in sensitivity and quieting will likely occur.

The low battery detection circuit gives an NPN open collector output at Pin 20 which drops low when the MC3367 supply voltage drops below 1.1 V. Typically it would be pulled up via a 100 k $\Omega$  resistor to supply.

The 1.2 V Select pin, when connected to the MC3367 supply, programs the low battery detector to trip at V<sub>CC</sub> < 1.1 V. Leaving this pin open raises the trip voltage on the low battery detector.

Pin 16 is a receiver enable which is connected to V<sub>CC</sub> for normal operation. Connecting this pin to ground shuts off receiver and reduces current drain to I<sub>CC</sub> < 0.5  $\mu$ A.

**APPENDIX**

Design of 2nd Order Sallen-Key Low Pass Filters

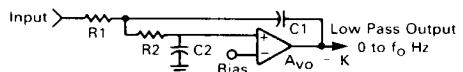

The audio and data buffers can easily be configured as active low pass filters using the circuit configuration shown above. The circuit has a center frequency (f<sub>0</sub>) and quality factor (Q) given by the following:

$$f_0 = \frac{1}{2\pi \sqrt{R1R2C1C2}}$$

$$Q = \frac{1}{\sqrt{\frac{R2C2}{R1C1} + \sqrt{\frac{R1C2}{R2C1}} + (1-K) \sqrt{\frac{R1C1}{R2C2}}}}$$

If possible, let R1 = R2 or C1 = C2 to simplify the above equations. Be sure to avoid a negative Q value to prevent instability. Setting Q = 1/ $\sqrt{2}$  = 0.707 yields a maximally flat filter response.



**Data Buffer Design**

The data buffer is designed as follows:

$$f_o = 200 \text{ Hz}$$

$$C1 = C2 = 0.01 \mu\text{F}$$

$$Q = 0.707 \text{ (target)}$$

K = 3.2 (data buffer open loop voltage gain)

Setting  $C1 = C2$  yields:

$$f_o = \frac{1}{2\pi C1 \sqrt{R1 R2}}$$

$$Q = \frac{1}{\sqrt{\frac{R2}{R1} + (2-K) \sqrt{\frac{R1}{R2}}}}$$

Iteration yields  $R2 = 4.2 (R1)$  to make  $Q = 0.707$ .Substitution into the equation for  $f_o$  yields:

$$R1 = 38 \text{ k}\Omega \text{ (use } 39 \text{ k}\Omega)$$

$$R2 = 4.2 (R1) = 180 \text{ k}\Omega$$

$$C1 = C2 = 0.01 \mu\text{F}$$

**Audio Buffer Design**

The audio buffer is designed as follows:

$$f_o = 3000 \text{ Hz}$$

$$R1 = R2 = 8.2 \text{ k}\Omega$$

$$Q = 0.707 \text{ (target)}$$

K = 4.0 (audio buffer open loop voltage gain)

Setting  $R1 = R2$  yields:

$$f_o = \frac{1}{2\pi R1 \sqrt{C1 C2}}$$

$$Q = \frac{1}{2 \sqrt{\frac{C2}{C1} + (1-K) \sqrt{\frac{C1}{C2}}}}$$

Iteration yields  $C2 = 2.65 (C1)$  to make  $Q = 0.707$ .Substitution into the equation for  $f_o$  yields:

$$C1 = 3900 \text{ pF}$$

$$C2 = 2.65 (C1) = 0.01 \mu\text{F}$$

$$R1 = R2 = 8.2 \text{ k}\Omega$$