

SP5055

2.5 GHz BI-DIRECTIONAL I²C BUS CONTROLLED SYNTHESISER

The SP5055 is a single chip frequency synthesiser designed for TV tuning systems. Control data is entered in the standard I²C BUS format. The device contains 4 addressable current limited outputs and 4 addressable Bi-Directional open collector ports one of which is a 3 Bit ADC. The information on these ports can be read via the I²C BUS. The device has one fixed I²C BUS address and 3 programmable addresses, programmed by applying a specific input voltage to one of the current limited outputs. This enables 2 or more synthesisers to be used in a system.

The device is available in two variants: the SP5055 in 18-lead plastic DIL (DP18) and the SP5055S in 16-lead miniature plastic DIL (MP16). See Features below for functional differences between the devices.

FEATURES

- Complete 2.5GHz Single Chip System
- Programmable via I²C BUS
- Low power consumption (5V 65mA)
- Low Radiation
- Phase Lock Detector
- Varactor Drive Amp Disable
- 8 Controllable Outputs, 4 Bi-Directional (SP5055)
- 6 Controllable Outputs, 4 Bi-Directional (SP5055S)
- 5 Level ADC
- Variable I²C BUS Address For Multi Tuner Applications
- Full ESD Protection *

* Normal ESD handling procedures should be observed.

APPLICATIONS

- Satellite TV
- High IF Cable Tuning Systems

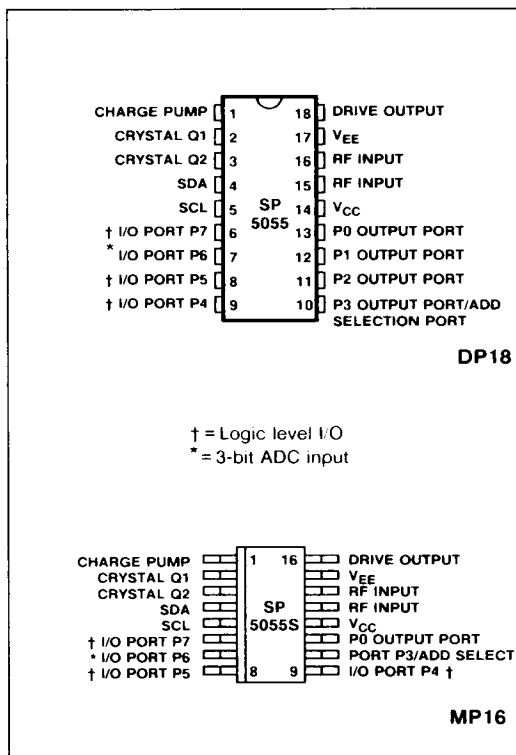

Fig.1 Pin connections - top view

ORDERING INFORMATION

- SP5055 DP - (18 lead Plastic package)
- SP5055S MP - (16 lead Miniature Plastic package)

ELECTRICAL CHARACTERISTICS**Test conditions (unless otherwise stated)** $T_{amb} = -10^{\circ}\text{C}$ to 80°C , $V_{CC} = +4.75\text{V}$ TO 5.25V

All pin connections refer to DP package.

These characteristics are guaranteed by either production test or design. They apply within the specified ambient temperature and supply voltage unless otherwise stated.

Characteristic	Pin	Value			Units	Conditions
		Min	Typ	Max		
Supply current	14		65	80	mA	$V_{CC} = 5\text{V}$
Prescaler Input Voltage	15,16	50		300	mV _{RMS}	500MHz to 1.8GHz
Prescaler Input Voltage	15,16	100		300	mV _{RMS}	2.5GHz, see Fig. 5
Prescaler Input Impedance	15,16		50		Ω	
Input Capacitance			2		pF	
SDA,SCL Input High Voltage	4,5	3		5.5	V	Input Voltage = V_{CC} Input Voltage = 0V When $V_{CC} = 0\text{V}$
Input Low Voltage	4,5	0		1.5	V	
Input High Current	4,5			10	μA	
Input Low Current	4,5			-10	μA	
Leakage Current	4,5			10	μA	
SDA Output Voltage	4			0.4	V	$I_{sink} = 3\text{mA}$
Charge Pump Current Low	1		± 50		μA	Byte 4 Bit 2 = 0, Pin 1 = 2V
Charge Pump Current High	1		± 170		μA	Byte 4 Bit 2 = 1, Pin 1 = 2V
Charge Pump Output Leakage Current	1			± 5	nA	Byte 4 Bit 4 = 1, Pin 1 = 2V
Charge Pump Drive Output Current	18	500			μA	$V_{pin\ 18} = 0.7\text{V}$
Charge Pump Amplifier Gain			6400			
Recommended Crystal Series Resistance		10		200	Ω	
Crystal Oscillator Drive Level			40		mV _{p-p}	
Crystal Oscillator Source Impedance	2		-400		Ω	Nominal Spread $\pm 15\%$
Output Ports						
P0-P3 Sink Current*	13-10	0.7	1	1.5	mA	$V_{OUT} = 12\text{V}$
P0-P3 Leakage Current*	13-10			10	μA	$V_{OUT} = 13.2\text{V}$
P4-P7 Sink Current	9-6	10			mA	$V_{OUT} = 0.7\text{V}$
P4-P7 Leakage Current	9-6			10	μA	$V_{OUT} = 13.2\text{V}$
Input Ports						
P3 Input Current High	10			+ 10	μA	$V_{pin\ 10} = 13.2\text{V}$
P3 Input Current Low	10			-10	μA	$V_{pin\ 10} = 0\text{V}$
P4,P5,P7 Input Voltage Low	9,8,6			0.8	V	
P4,P5,P7 Input Voltage High	9,8,6	2.7			V	
P6 Input Current High	7			+ 10	μA	See Table 3 for ADC Levels
P6 Input Current Low	7			-10	μA	

* Ports P1-P2 not present on the SP5055S.

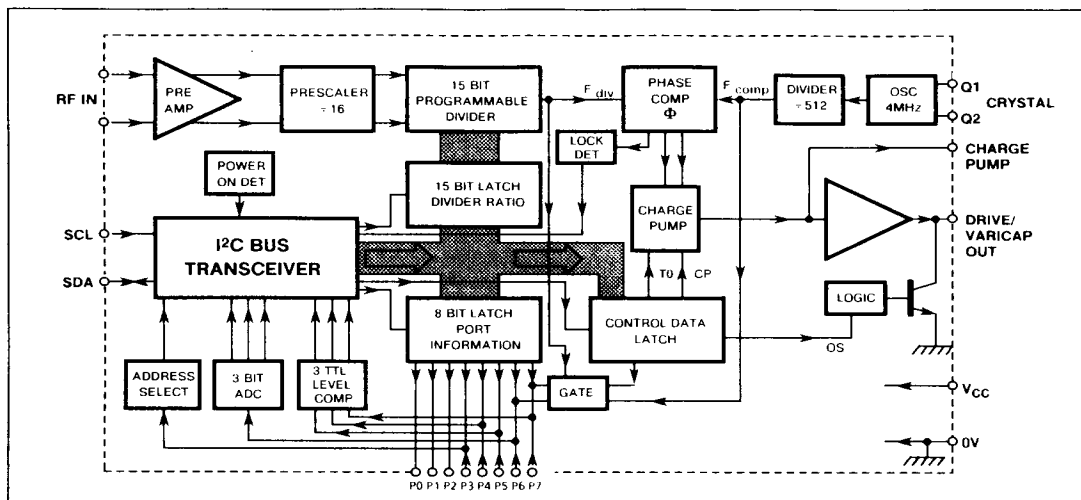

Fig.2 Block diagram of SP5055. (Ports P1-P2 not available on SP5055S)

FUNCTIONAL DESCRIPTION

The SP5055 is programmed from an I²C BUS. Data and Clock are fed in on the SDA and SCL lines respectively as defined by the I²C BUS format. The synthesiser can either accept new data (write mode) or send data (read mode). The Tables in Fig. 3 illustrate the format of the data. The device can be programmed to respond to several addresses, which enables the use of more than one synthesiser in an I²C BUS system. Table 4 shows how the address is selected by applying a voltage to P3. The last bit of the address byte (R/W) sets the device into read mode if it is high and write mode if it is low. When the SP5055 receives a correct address byte it pulls the SDA line low during the acknowledge period and during following acknowledge periods after further data bytes are programmed. When the SP5055 is programmed into the read mode the controlling device accepting the data must pull down the SDA line during the following acknowledge period to read another status byte.

WRITE MODE (FREQUENCY SYNTHESIS)

When the device is in the write mode bytes 2+3 select the synthesised frequency while bytes 4+5 select the output port states and charge pump information.

Once the correct address is received and acknowledged, the first bit of the next Byte determines whether that Byte is interpreted as byte 2 or 4, a logic 0 for frequency information and a logic 1 for charge pump and output port information. Additional data bytes can be entered without the need to re-address the device until an I²C stop condition is recognised. This allows a smooth frequency sweep for fine tuning or AFC purposes.

If the transmission of data is stopped mid-byte (e.g. by another device on the bus) then the previously programmed byte is maintained.

Frequency data from bytes 2 and 3 is stored in a 15-bit shift register and is used to control the division ratio of the 15-bit programmable divider which is preceded by a divide-by-16 prescaler and amplifier to give excellent sensitivity at the local oscillator input, see Fig. 5. The input impedance is shown in Fig 7.

The programmed frequency can be calculated by multiplying the programmed division ratio by 16 times the comparison frequency F_{comp} .

When frequency data is entered, the phase comparator, via the charge pump and varicap drive amplifier, adjusts the local oscillator control voltage until the output of the programmable divider is frequency and phase locked to the comparison frequency.

The reference frequency may be generated by an external source capacitively coupled into pin 2 or provided by an on-board 4MHz crystal controlled oscillator.

Note - the comparison frequency is 7.8125KHz when a 4MHz reference is used.

Bit 2 of byte 4 of the programming data (CP) controls the current in the charge pump circuit, a logic 1 for $\pm 170\mu A$ and a logic 0 for $\pm 50\mu A$ allowing compensation for the variable tuning slope of the tuner and also to enable fast channel changes over the full band. Bit 4 of byte 4 (T0) disables the charge pump if set to a logic 1. Bit 8 of byte 4 (OS) switches the charge pump drive amplifier's output off when it is set to a logic 1. Bit 3 of byte 4 (T1) selects a test mode where the phase comparator inputs are available on P6 and P7, a logic 1 connects F_{comp} to P6 and F_{div} to P7.

Byte 5 programs the output ports P0 to P7; a logic 0 for a high impedance output and a logic 1 for low impedance (on).

READ MODE

When the device is in the read mode the status data read from the device on the SDA line takes the form shown in Table 2.

Bit 1 (POR) is the power-on reset indicator and is set to a logic 1 if the power supply to the device has dropped below 3V and the programmed information lost (e.g., when the device is initially turned on). The POR is set to 0 when the read sequence is terminated by a stop command. The outputs are all set to high impedance when the device is initially powered up. Bit 2 (FL) indicates whether the device is phase locked, a logic 1 is present if the device is locked and a logic 0 if the device is unlocked.

Bits 3, 4 and 5 (I2,I1,I0) show the status of the I/O Ports P7, P5 and P4 respectively. A logic 0 indicates a low level and a logic 1 a high level. If the ports are to be used as inputs they should be programmed to a high impedance state (logic 1). These inputs will then respond to data complying with TTL type voltage levels. Bits 6, 7 and 8 (A2,A1,A0) combine to give the output of the 5 level ADC.

The 5 level ADC can be used to feed AFC information to the microprocessor from the IF section of the receiver, as illustrated in the typical application circuit.

APPLICATION

A typical Application is shown in Fig. 4. All input/ output interface circuits are shown in Fig. 6.

	MSB					LSB				
ADDRESS	1	1	0	0	0	MA1	MA0	0	A	BYTE 1
PROGRAMMABLE DIVIDER	0	2 ¹⁴	2 ¹³	2 ¹²	2 ¹¹	2 ¹⁰	2 ⁹	2 ⁸	A	BYTE 2
PROGRAMMABLE DIVIDER	2 ⁷	2 ⁶	2 ⁵	2 ⁴	2 ³	2 ²	2 ¹	2 ⁰	A	BYTE 3
CHARGE PUMP AND TEST BITS	1	CP	T1	T0	1	1	1	OS	A	BYTE 4
IO PORT CONTROL BITS	P7	P6	P5	P4	P3	P2*	P1*	P0	A	BYTE 5

Table 1 Write data format (MSB is transmitted first)

ADDRESS	1	1	0	0	0	MA1	MA0	1	A	BYTE 1
STATUS BYTE	POR	FL	I2	I1	I0	A2	A1	A0	A	BYTE 2

Table 2 Read data format

- A : Acknowledge Bit
- MA1, MA0 : Variable address bits (see Table 4)
- CP : Charge Pump current select
- T1 : Test mode selection
- T0 : Charge pump disable
- OS : Varactor drive Output disable Switch
- P7, P6, P5, P4, P3, P2*, P1*, P0 : control output states
- POR : Power On Reset indicator
- FL : Phase Lock detect Flag
- I2, I1, I0 : Digital information from Ports P7, P5 and P4, respectively
- A2, A1, A0 : 5 Level ADC data from P6 (see Table 3)

A2	A1	A0	Voltage input to P6
1	0	0	0.6V _{CC} to 13.2V
0	1	1	0.45V _{CC} to 0.6V _{CC}
0	1	0	0.3V _{CC} to 0.45V _{CC}
0	0	1	0.15V _{CC} to 0.3V _{CC}
0	0	0	0 to 0.15V _{CC}

Table 3 ADC levels

MA1	MA0	Voltage input to P3
0	0	0 - 0.2V _{CC}
0	1	ALWAYS VALID
1	0	0.3 - 0.7V _{CC}
1	1	0.8V _{CC} - 13.2V

Table 4 Address selection

NOTE: * Don't care condition on SP5055S

Fig. 3 Data Formats

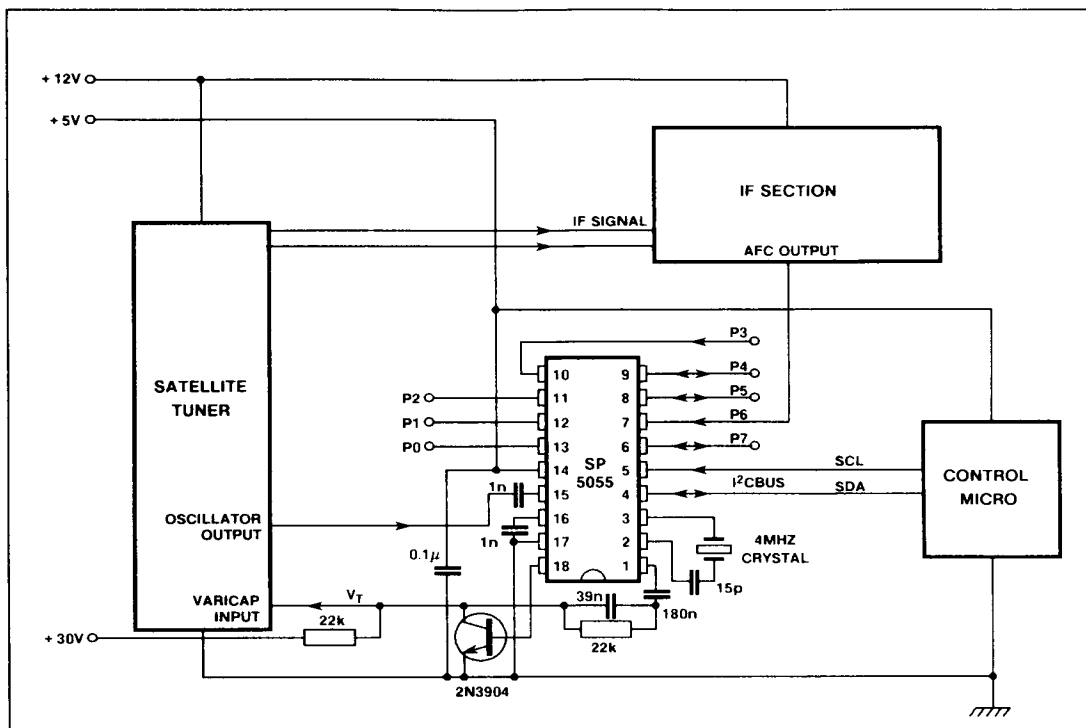

Fig.4 Typical SP5055 application

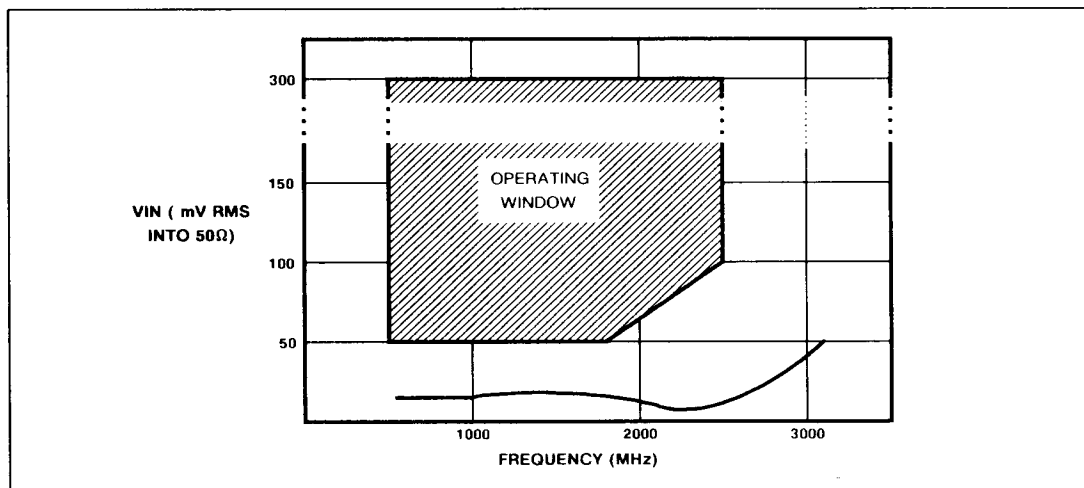

Fig.5 Typical input sensitivity

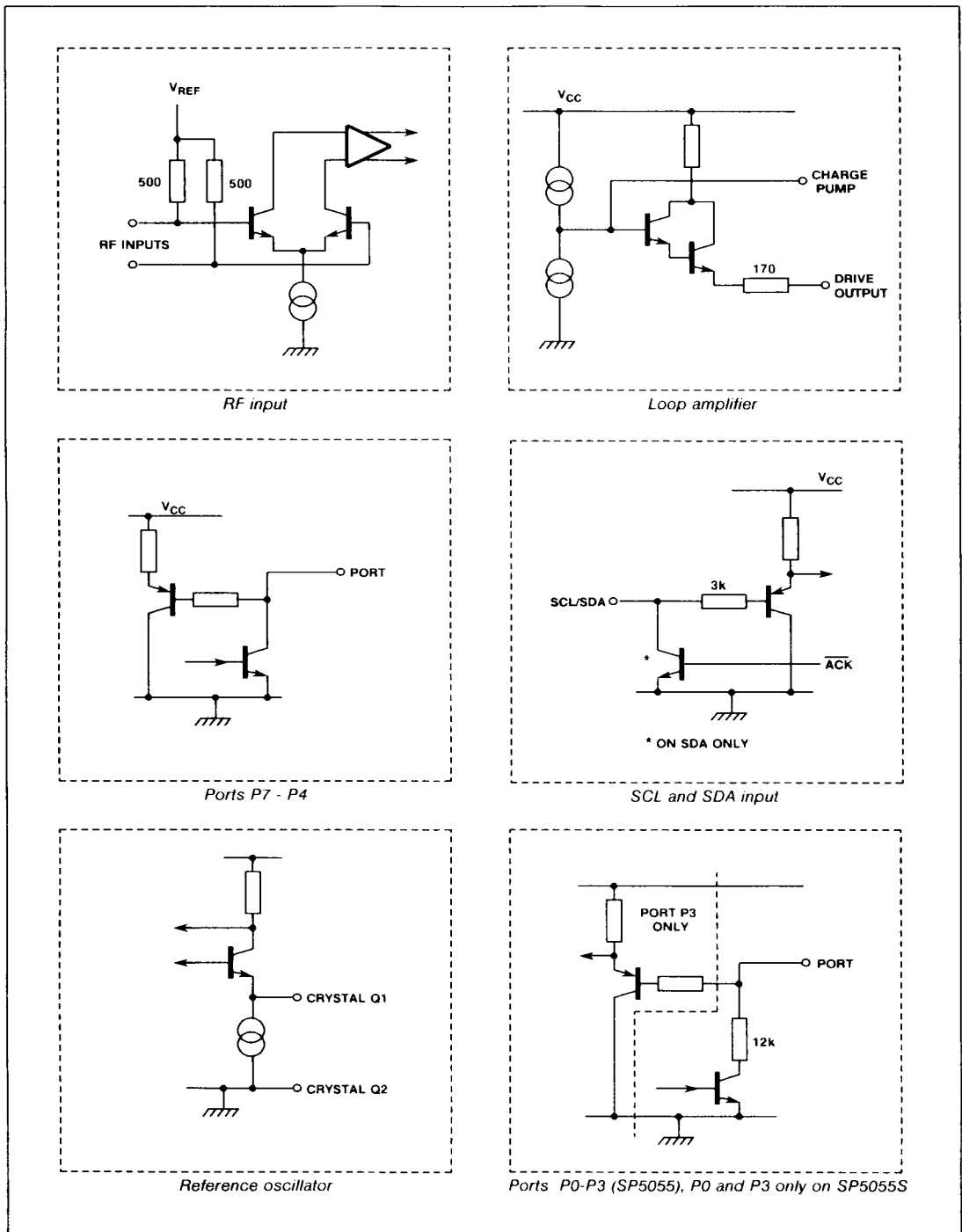

Fig.6 SP5055 input/output interface circuits

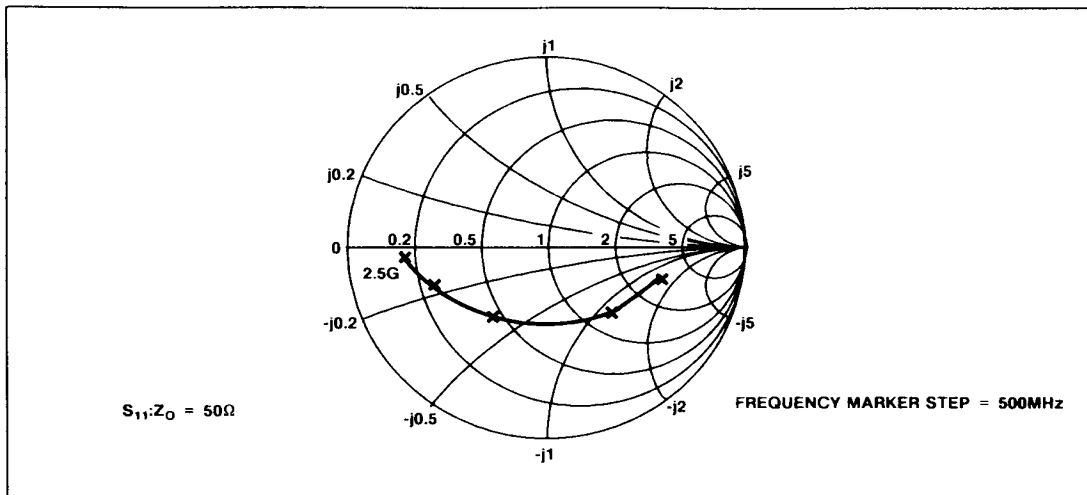

Fig.7 Typical input impedance

ABSOLUTE MAXIMUM RATINGSAll voltages are referred to V_{EE} and pin 3 at 0V.

Parameter	Pin SP5055	Pin SP5055S	Value		Units	Conditions
			Min	Max		
Supply voltage	14	12	-0.3	7	V	
RF input voltage	15, 16	13, 14		2.5	Vp-p	
Port voltage	6 - 13	6 - 11	-0.3	14	V	Port in off state
			-0.3	6	V	Port in on state
			-0.3	14	V	Port in on state
Total port output current	6-13	6-11		50	mA	
RF input DC offset	15, 16	13, 14	-0.3	$V_{CC} + 0.3$	V	
Charge pump DC offset	1	1	-0.3	$V_{CC} + 0.3$	V	
Drive DC offset	18	16	-0.3	$V_{CC} + 0.3$	V	
Crystal oscillator DC offset	2	2	-0.3	$V_{CC} + 0.3$	V	
SDA, SCL input voltage	4, 5	4, 5	-0.3	$V_{CC} + 0.3$	V	With V_{CC} applied V_{CC} not applied
			-0.3	5.5	V	
Storage temperature			-55	+ 125	°C	
Junction temperature				+ 150	°C	
DP18 thermal resistance, chip-to-ambient				78	°C/W	
DP18 thermal resistance, chip-to-case				24	°C/W	
MP16 thermal resistance, chip-to-ambient				111	°C/W	
MP16 thermal resistance, chip-to-case				41	°C/W	
Power consumption at 5.5V				440	mW	All ports off