

MB1501/MB1501H/MB1501L

SERIAL INPUT PLL FREQUENCY SYNTHESIZER

SERIAL INPUT PLL FREQUENCY SYNTHESIZER WITH 1.1GHz PRESCALER

The Fujitsu MB1501/MB1501H/MB1501L, utilizing BI-CMOS technology, is a single chip serial input PLL frequency synthesizer with pulse-swallow function.

The MB1501 series contain a 1.1GHz two modulus prescaler that can select either 64/65 or 128/129 divide ratio; control signal generator; 16-bit shift register; 15-bit latch; programmable reference divider (binary 14-bit programmable reference counter); 1-bit switch counter; phase comparator with phase inverse function; charge pump; crystal oscillator; 19-bit shift register; 18-bit latch; programmable divider (binary 7-bit swallow counter and binary 11-bit programmable counter).

The MB1501 operates on a low supply voltage (3V typ) and consumes low power (45mW at 1.1GHz).

MB1501 Product Line

	V _P Voltage	V _{OP} Voltage	Lock up time	D _O Output Width	High-level Output Current	Low-level Output Current
MB1501	8V max	8.5V max	Middle speed	Middle	Middle	Middle
MB1501H	10V max	10.0V max	High speed	Low	High	Low
MB1501L	8V max	8.5V max	Low speed	High	Low	High

- High operating frequency: $f_{IN\ MAX}=1.1GHz$ ($P_{IN\ MIN}=0.20V_{P-P}$)
- On-chip prescaler
- Low power supply voltage: 2.7V to 5.5V (3.0V typ)
- Low power supply consumption: 45mW (3.0V, 1.1GHz operation)
- Serial input 18-bit programmable divider consisting of:
 - Binary 7-bit swallow counter (Divide ratio: 0 to 127)
 - Binary 11-bit programmable counter (Divide ratio: 16 to 2047)
- Serial input 15-bit programmable reference divider consisting of:
 - Binary 14-bit programmable reference counter (Divide ratio: 8 to 16383)
 - 1-bit switch counter (SW) Sets divide ratio of prescaler
- 2types of phase detector output
 - On-chip charge pump (Bipolar type)
 - Output for external charge pump
- Wide operating temperature: $T_A=-40^{\circ}C$ to $+85^{\circ}C$

ABSOLUTE MAXIMUM RATINGS (see NOTE)

Rating	Symbol	Condition	Value	Unit
Power Supply Voltage	V _{CC}		-0.5 to +7.0	V
	V _{PH}	MB1501H	V _{CC} to 12.0	V
	V _P ,V _{PL}	MB1501/1501L	V _{CC} to 10.0	
Output Voltage	V _{OUT}		-0.5 to V _{CC} +0.5	V
Open-drain Output	V _{OOPH}	MB1501H	-0.5 to 11.0	V
	V _{OOP} ,V _{OOPL}	MB1501/1501L	-0.5 to 9.0	
Output Current	I _{OUT}		±10	mA
Storage Temperature	T _{STG}		-55 to +125	°C

NOTE: Permanent device damage may occur if the above **Absolute Maximum Ratings** are exceeded. Functional operation should be restricted to the conditions as detailed in the operational sections of this data sheet. Exposure to absolute maximum rating conditions for extended periods may affect device reliability.

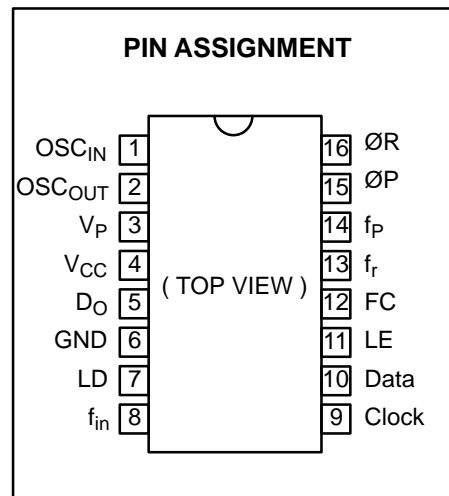
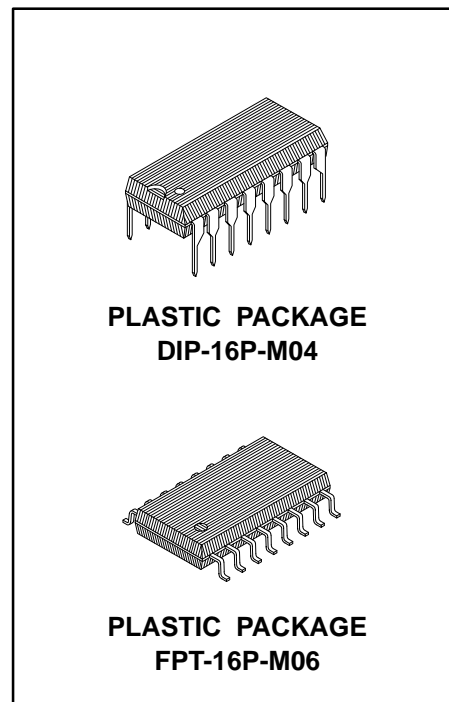

This device contains circuitry to protect the inputs against damage due to high static voltages or electric fields. However, it is advised that normal precautions be taken to avoid application of any voltage higher than maximum rated voltages to this high impedance circuit.

MB1501
MB1501H
MB1501L

MB1501/MB1501H/MB1501L BLOCK DIAGRAM

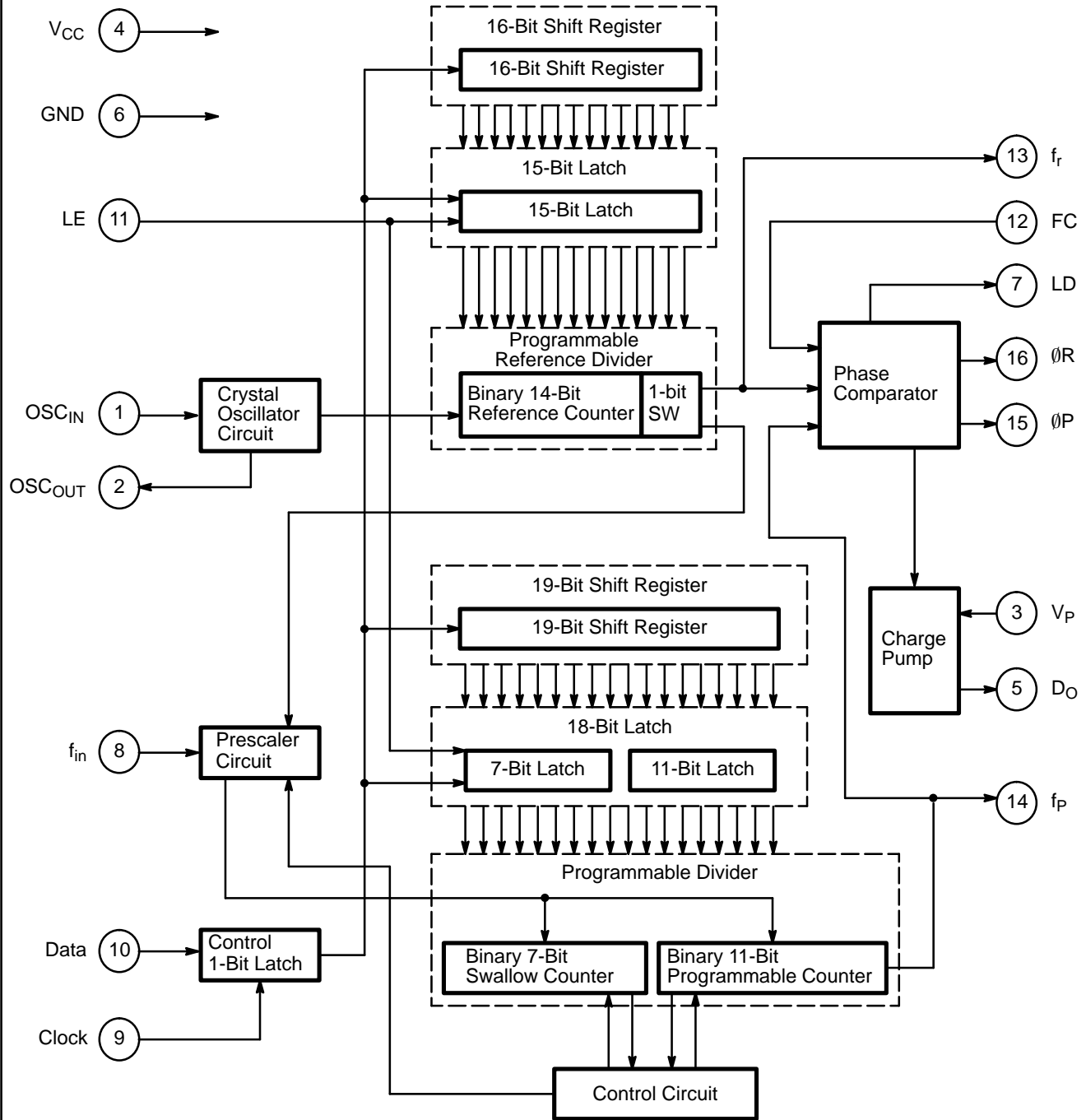

PIN DESCRIPTIONS

Pin No.	Pin Name	I/O	Descriptions
1 2	OSC _{IN} OSC _{OUT}	I O	Oscillator input. Oscillator output. A crystal is placed between OSC _{IN} and OSC _{OUT} .
3	V _P	—	Power supply input for charge pump.
4	V _{CC}	—	Power supply voltage input.
5	D _O	O	Charge pump output. Phase characteristic can be inversed depending upon FC input.
6	GND	—	Ground.
7	LD	O	Phase comparator output. This pin outputs high when the phase is locked. While the phase difference of f _r and f _p exists, the output level goes low.
8	f _{in}	I	Prescaler input. The connection with an external VCO should be an AC connection.
9	Clock	I	Clock input for 19-bit shift register and 16-bit shift register. Each rising edge of the clock shifts one bit of data into the shift registers.
10	Data	I	Serial data of binary code input. The last bit of the data is a control bit. The last data bit specifies which latch is activated. When the last bit is high level and LE is high-level, data is transferred to 15-bit latch. When the last bit is low level and LE is high level, data is transferred to 18-bit latch.
11	LE	I	Load enable input (with internal pull up resistor). When LE is high level (or open), data stored in the shift register is transferred to latch depending on the control data.
12	FC	O	Phase selecting input of phase comparator (with internal pull up resistor). When FC is low level, charge pump and phase detector characteristics can be inversed.
13	f _r	O	Monitor pin of phase comparator input. It is the same as programmable reference divider output.
14	f _p	O	Monitor pin of phase comparator input. It is the same as programmable divider output.
15 16	ØP ØR	O O	Outputs for external charge pump. Phase characteristics can be inversed depending on FC input. ØP pin is an N-channel open-drain output.

FUNCTIONAL DESCRIPTIONS

SERIAL DATA INPUT

Serial data input is input using Data pin, Clock pin and LE pin, The 15-bit programmable reference divider and 18-bit programmable divider are controlled respectively.

On rising edge of the clock shifts one bit of the data into the internal shift registers.

When load enable (LE) is high level (or open), data stored in shift registers is transferred to 15-bit latch or 18-bit latch depending upon the control bit level.

Control data "H" ; Data is transferred into 15-bit latch.

Control data "L" ; Data is transferred into 18-bit latch.

PROGRAMMABLE REFERENCE DIVIDER

Programmable reference divider consists of 16-bit shift register, 15-bit latch and 14-bit reference counter. Serial 16-bit data format is shown below.

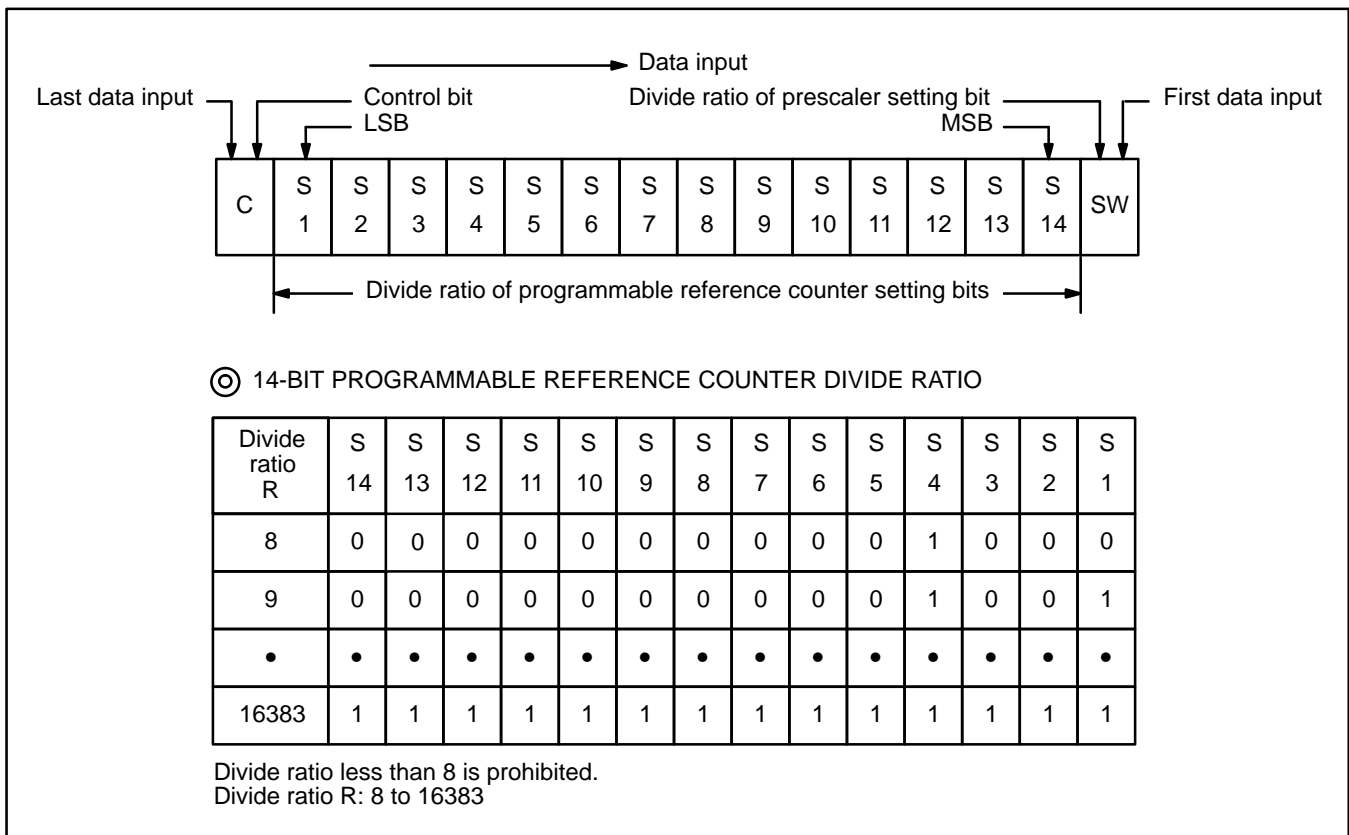

SW: Divide ratio of prescaler setting bit.

SW="H" : 64

SW="L" : 128

S₁ to S₁₄: Divide ratio of programmable reference counter setting bits (8 to 16383)

C: Control bit (Control bit is set to high.)

FUNCTIONAL DESCRIPTIONS

PROGRAMMABLE DIVIDER

Programmable divider consists of 19-bit shift register, 18-bit latch, 7-bit swallow counter and 11-bit programmable counter. Serial 19-bit data format is shown below.

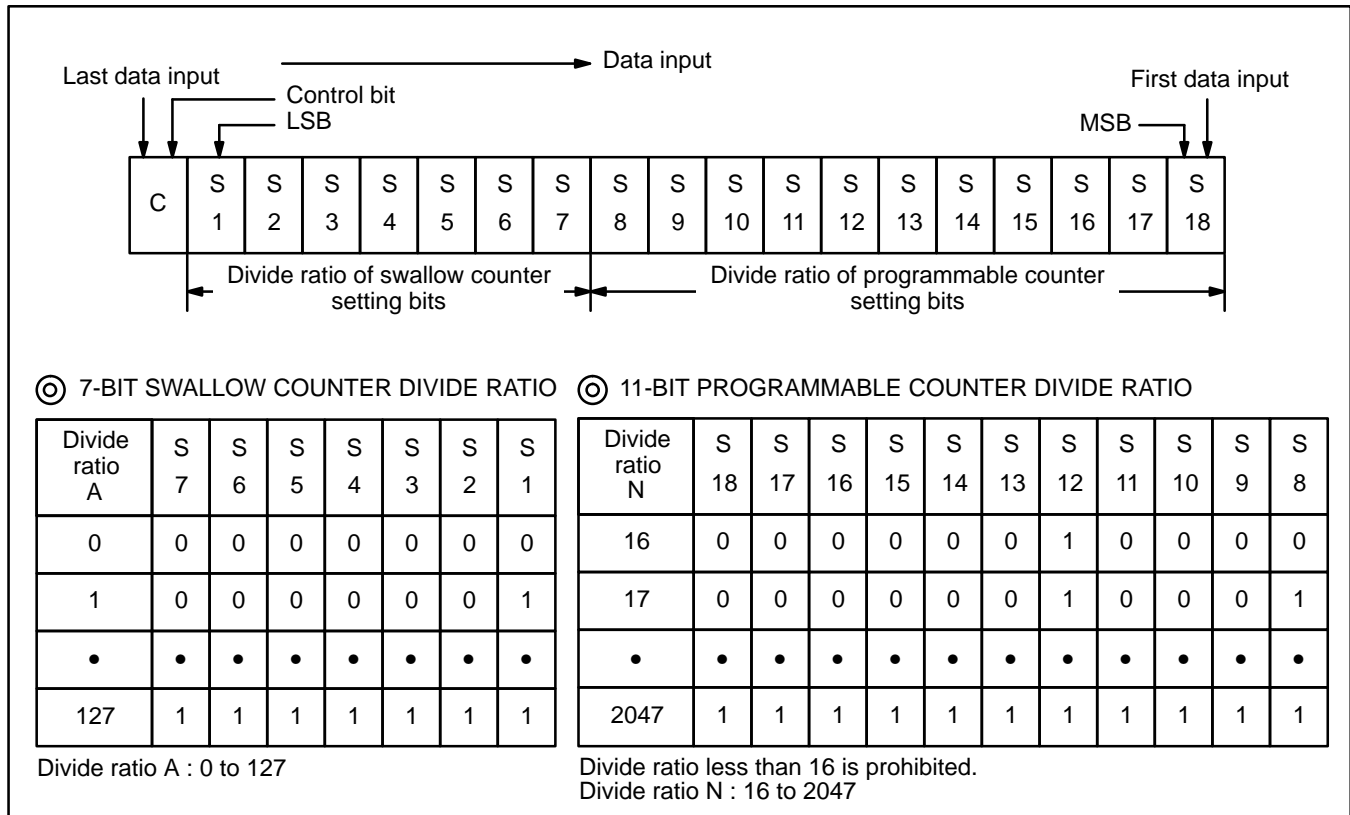

S₈ to S₁₈ : Divide ratio of programmable counter setting bits (16 to 2047)
S₁ to S₇ : Divide ratio of swallow counter setting bits (0 to 127)
C: Control bit (Control bit is set to low.)
Data is input from MSB data.

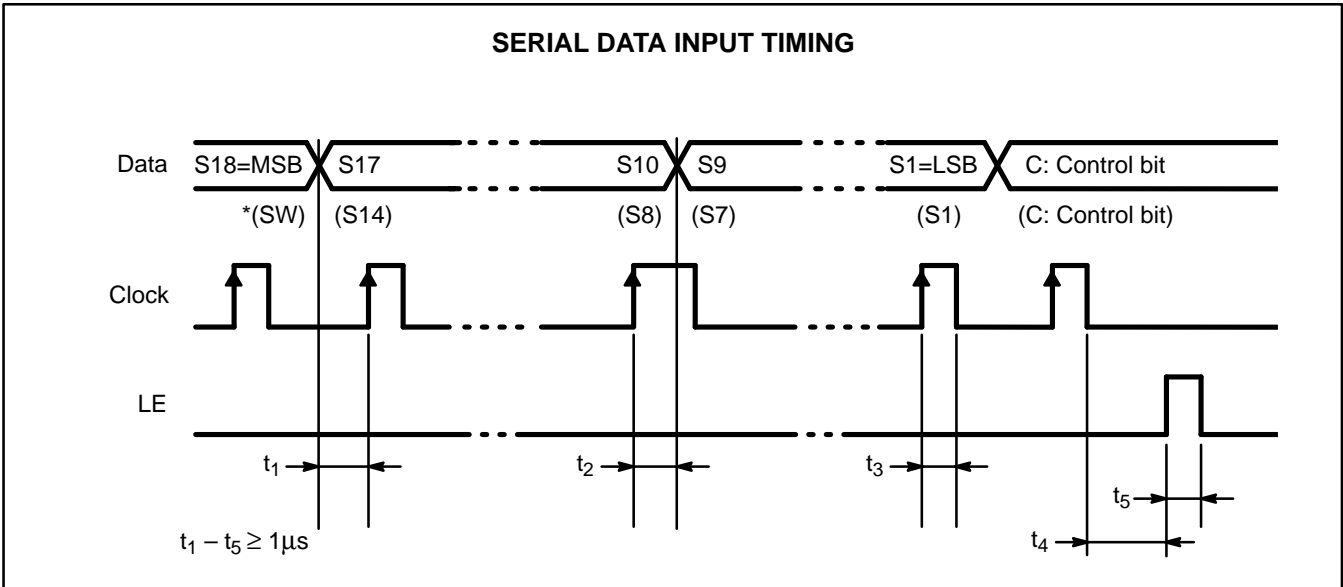

On the rising edge of the clock shifts one bit of the data into the shift registers. Parenthesis data is used for setting the divide ratio of the programmable reference divider.

PHASE CHARACTERISTICS

FC pin (pin 12) is provided to inverse the phase comparator characteristics. The characteristics of internal charge pump output (D_O), phase detector outputs ($\emptyset R$, $\emptyset P$) can be inverted depending upon FC input data. Outputs are shown below.

	FC=H (or open)			FC=L		
	D_O	$\emptyset R$	$\emptyset P$	D_O	$\emptyset R$	$\emptyset P$
$f_r > f_p$	H	L	L	L	H	Z
$f_r < f_p$	L	H	Z	H	L	L
$f_r = f_p$	Z	L	Z	Z	L	Z

Note: Z=(High impedance)

Depending upon VCO characteristics, FC pin should be set accordingly:

When VCO characteristics are like ①, FC should be set high or open circuit;

When VCO characteristics are like ②, FC should be set Low.

VCO CHARACTERISTICS

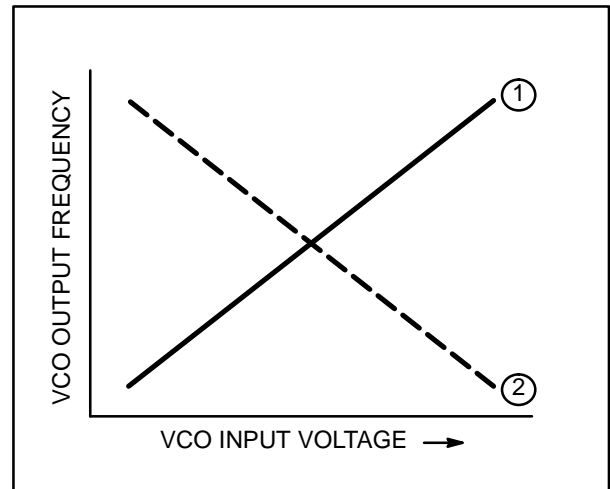

RECOMMENDED OPERATING CONDITIONS

Parameter	Symbol		Value			Unit
			Min	Typ	Max	
Power Supply Voltage	V_{CC}		2.7	3.0	5.5	V
	V_{PH}	MB1501H	V_{CC}		10.0	V
	V_P, V_{PL}	MB1501 MB1501L	V_{CC}		8.5	
Open-drain Output	V_{OOPH}	MB1501H	V_{CC}		10.0	V
	V_{OOP}, V_{OOPL}	MB1501 MB1501L	V_{CC}		8.5	
Input Voltage	V_{IN}		GND		V_{CC}	V
Operating temperature	T_A		-40		+85	°C

ELECTRICAL CHARACTERISTICS

($V_{CC}=2.7$ to $5.5V$, $T_A=-40$ to $+85^{\circ}C$)

Parameter	Pin Name	Symbol	Condition	Value			Unit	
				Min	Typ	Max		
Power Supply Current	V_{CC}	I_{CC}	*1	—	15	—	mA	
Operating Frequency	f_{in}	f_{IN}	*2	10	—	1100	MHz	
	OSC_{IN}	f_{OSC}		—	12	20	MHz	
Input Sensitivity	f_{in}	P_{fin1}	$V_{CC}=2.7$ to $4.0V$	-10	—	6	dBm	
		P_{fin2}	$V_{CC}=4.0$ to $5.5V$	-4	—	6	dBm	
	OSC_{IN}	V_{IN}		0.5	—	—	V_{P-P}	
High-level Input Voltage	Except f_{in} and OSC_{IN}	V_{IH}		$0.7 \times V_{CC}$	—	—	V	
Low-level Input Voltage		V_{IL}		—	—	$0.3 \times V_{CC}$	V	
High-level Input Current	Data, Clock	I_{IH}		—	1.0	—	μA	
Low-level Input Current		I_{IL}		—	-1.0	—	μA	
Input Current	OSC_{IN}	I_{IN}		—	± 50	—	μA	
	LE, FC	I_{LE}		—	-60	—	μA	
High-level Output Voltage	Except D_O and OSC_{OUT}	V_{OH}	$V_{CC}=3.0V$	2.4	—	—	V	
Low-level Output Voltage		V_{OL}		—	—	0.4	V	
N-channel Open-drain Cutoff Current	$\emptyset P$	I_{OFF}	$V_{CC} \leq V_P \leq 8V$	—	—	1.1	μA	
High-level Output Current	Except D_O and OSC_{OUT}	I_{OH}		-1.0	—	—	mA	
Low-level Output Current		I_{OL}		1.0	—	—	mA	
High-level Output Current	D_O	I_{DOHH}	MB1501H	$V_{CC}=3V$ $V_P=12V$, $T_A=25^{\circ}C$	-2.2	-4.5	—	mA
		I_{DOH}	MB1501	$V_{CC}=3V$ $V_P=6V$, $T_A=25^{\circ}C$	-0.5	-2.0	—	mA
		I_{DOHL}	MB1501L		-0.5	-1.1	-2.2	mA
Low-level Output Current		I_{DOLH}	MB1501H	$V_{CC}=3V$ $V_P=12V$, $T_A=25^{\circ}C$	2.2	6.0	—	mA
		I_{DOL}	MB1501	$V_{CC}=3V$ $V_P=6V$, $T_A=25^{\circ}C$	1.5	6.0	—	mA
		I_{DOLL}	MB1501L		4.5	12.0	—	mA
Leakage Current	D_O , $\emptyset P$	I_{OZ}	MB1501H	$V_{CC}=3V$, $V_P=12V$ $T_A=25^{\circ}C$	—	1.0	μA	
			MB1501	$V_{CC}=3V$, $V_P=9V$ $T_A=25^{\circ}C$				
			MB1501L					

Note: *1 $V_{CC}=3.0V$, $f_{IN}=1.1GHz$, $f_{OSC}=12MHz$ crystal.
 Inputs are grounded except f_{IN} , and outputs are open.
 *2 Input coupling capacitor 1000pF is connected.

TYPICAL CHARACTERISTICS CURVES

CHARGE PUMP CHARACTERISTICS

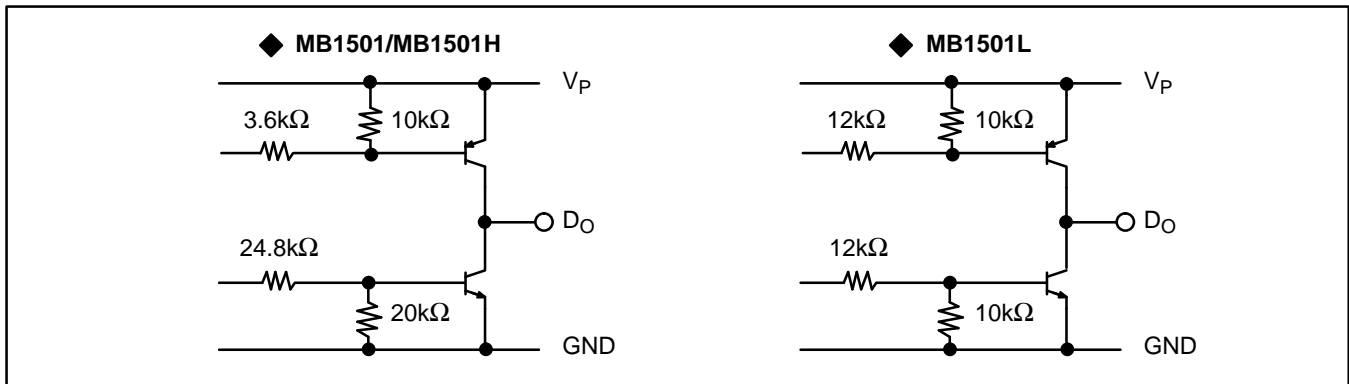

LOCK UP TIME MEASUREMENT

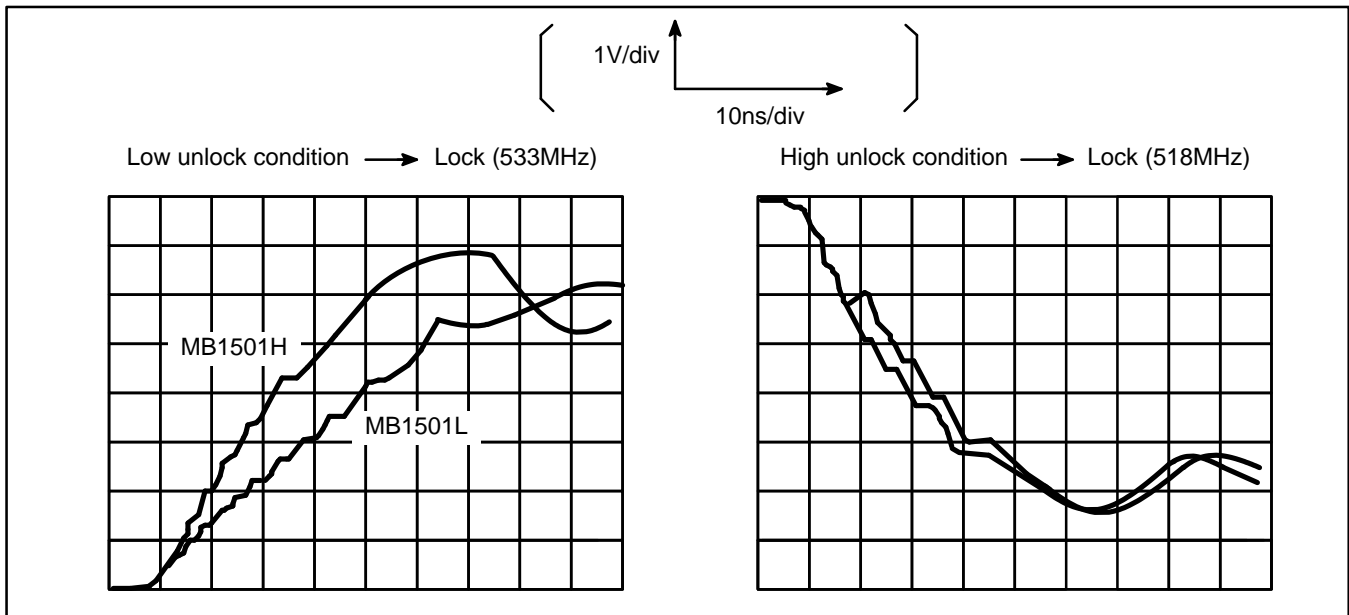

DO PIN OUTPUT CURRENT CURVES (TYPICAL)

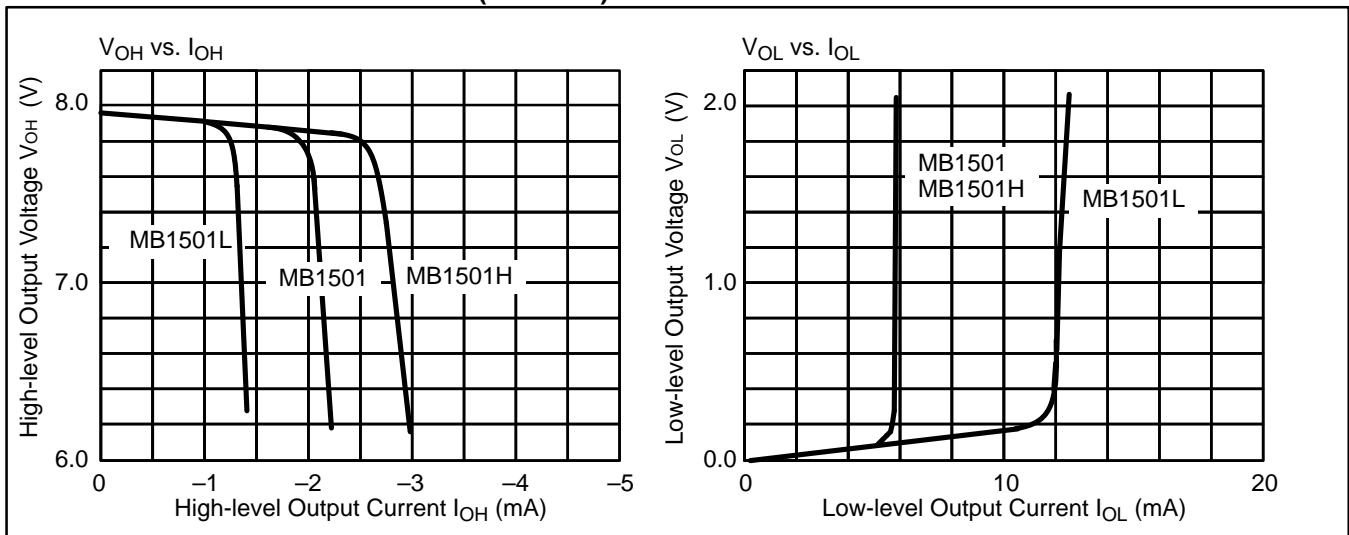

D_O PIN OUTPUT WAVEFORM AT LOCK CONDITION

Output Waveform

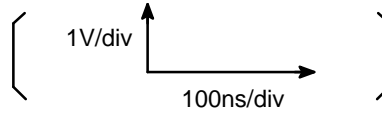

MB1501

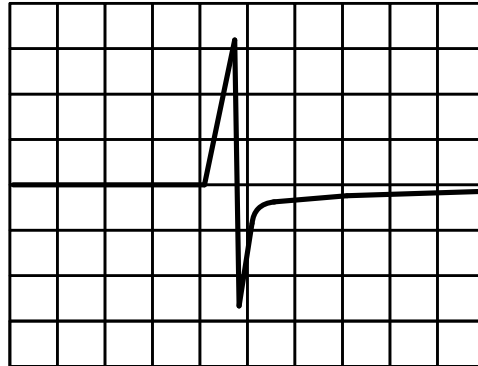

MB1501H

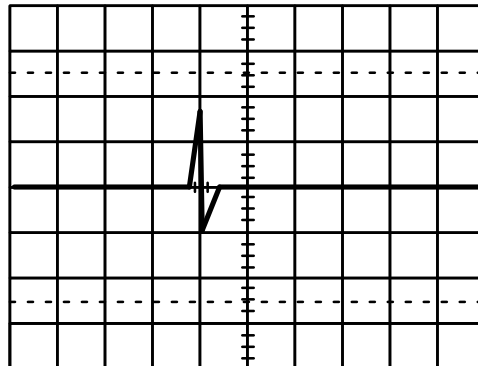

MB1501L

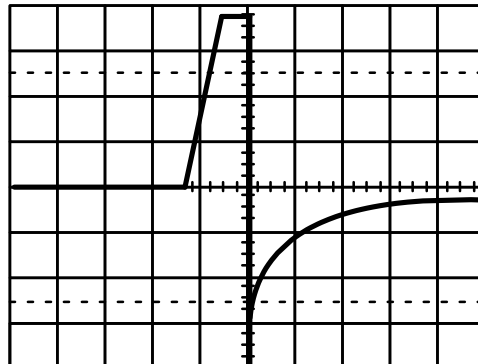

PHASE CHARACTERISTICS (Δf vs. D_O OUTPUT ENERGY)

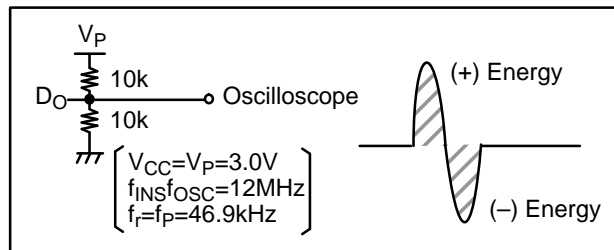
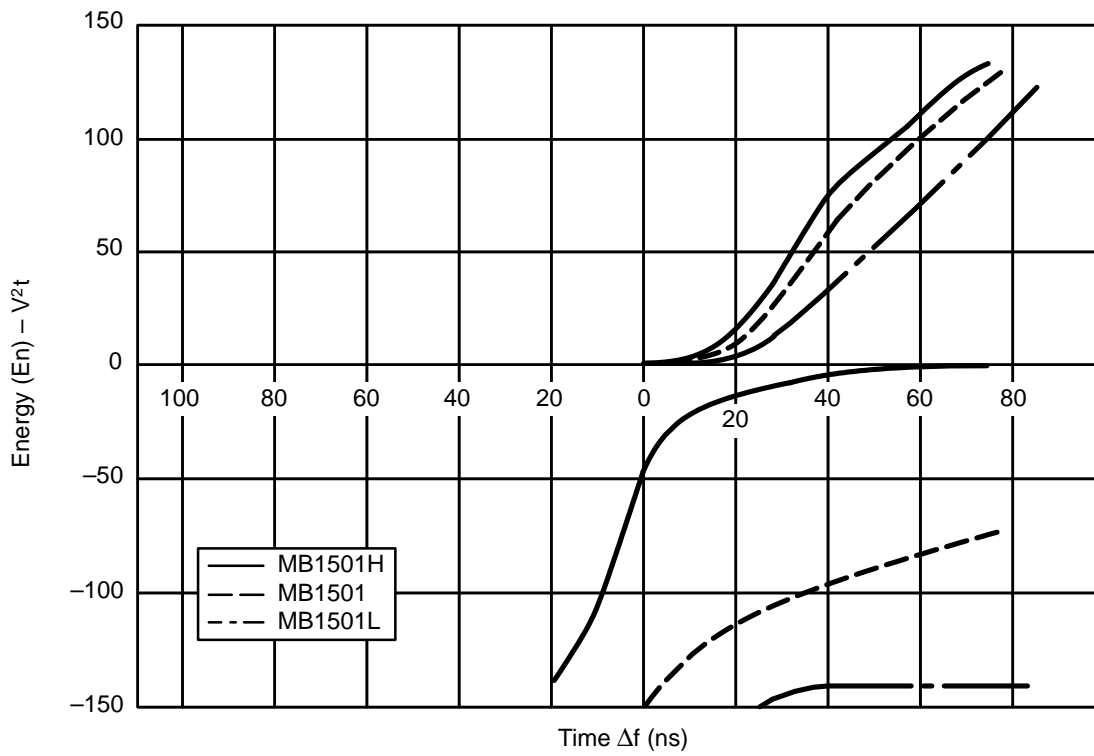

INPUT SENSITIVITY

Input Sensitivity vs. Input Frequency (Supply Voltage Dependence)

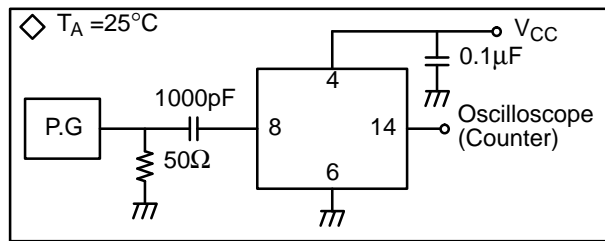
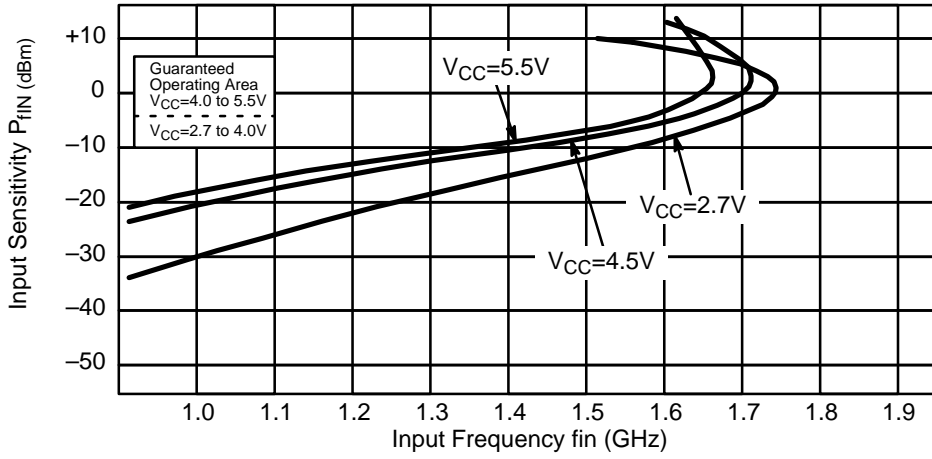

Input Sensitivity vs. Input Frequency (Temperature Dependence)

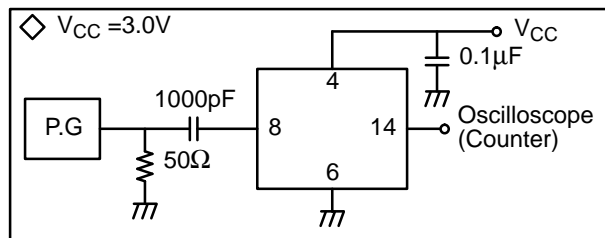
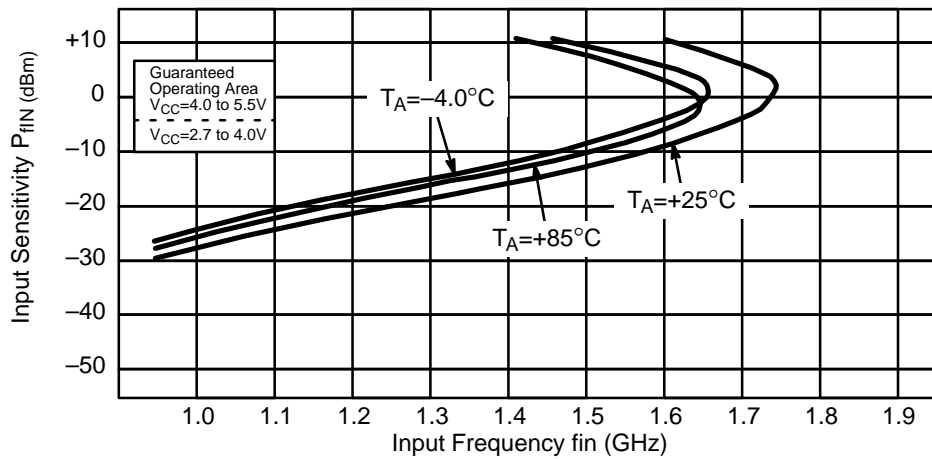

INPUT IMPEDANCE

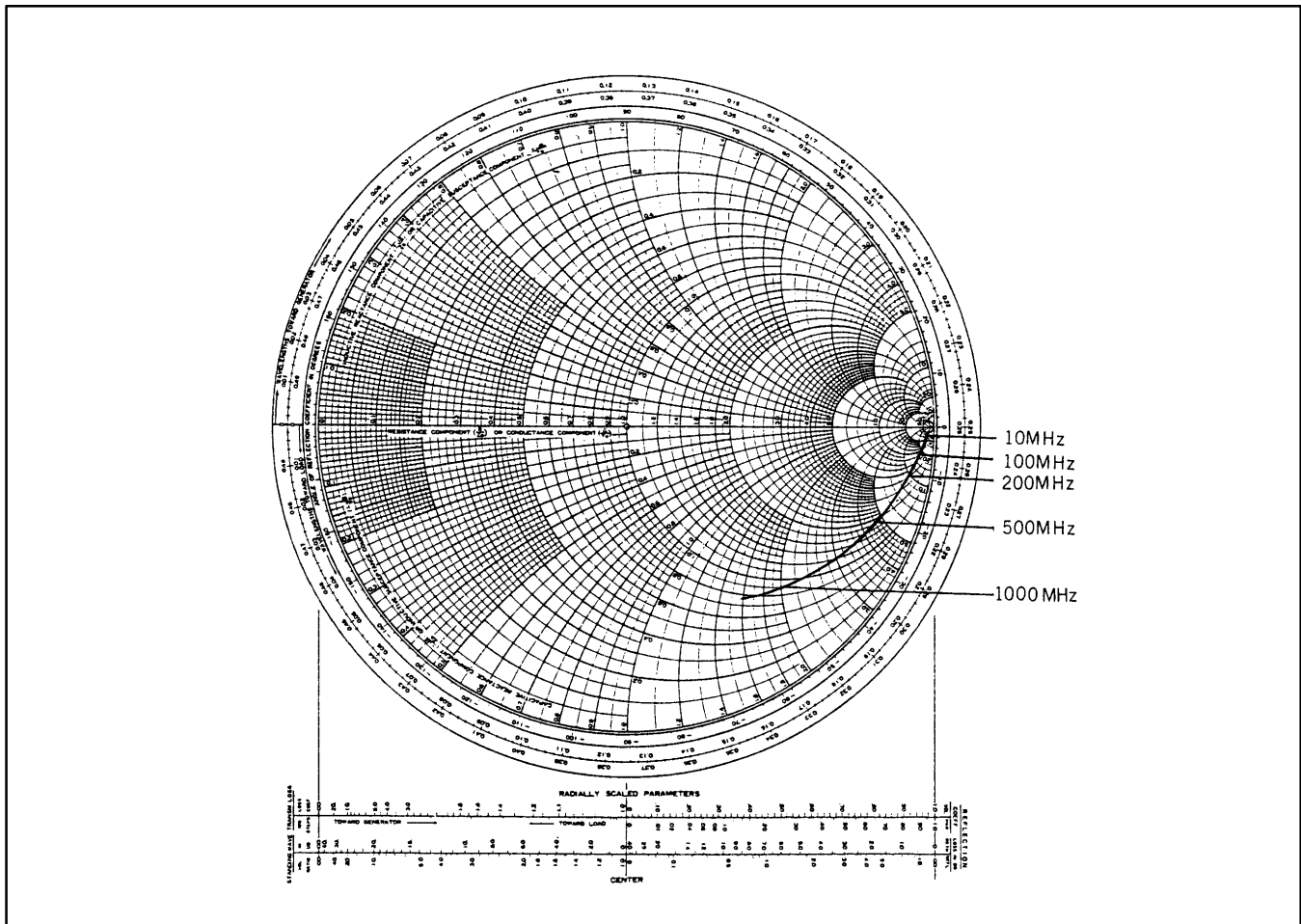

TEST CIRCUIT

D_O Pin Output Current (I_{OH}, I_{OL}) Measurement

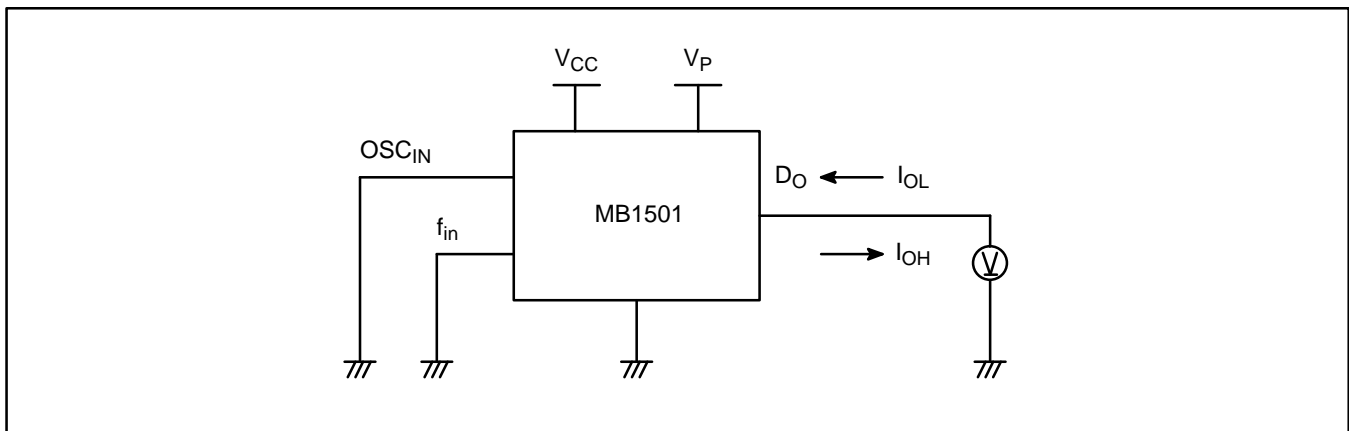

MB1501
MB1501H
MB1501L

Lock up Time Measurement

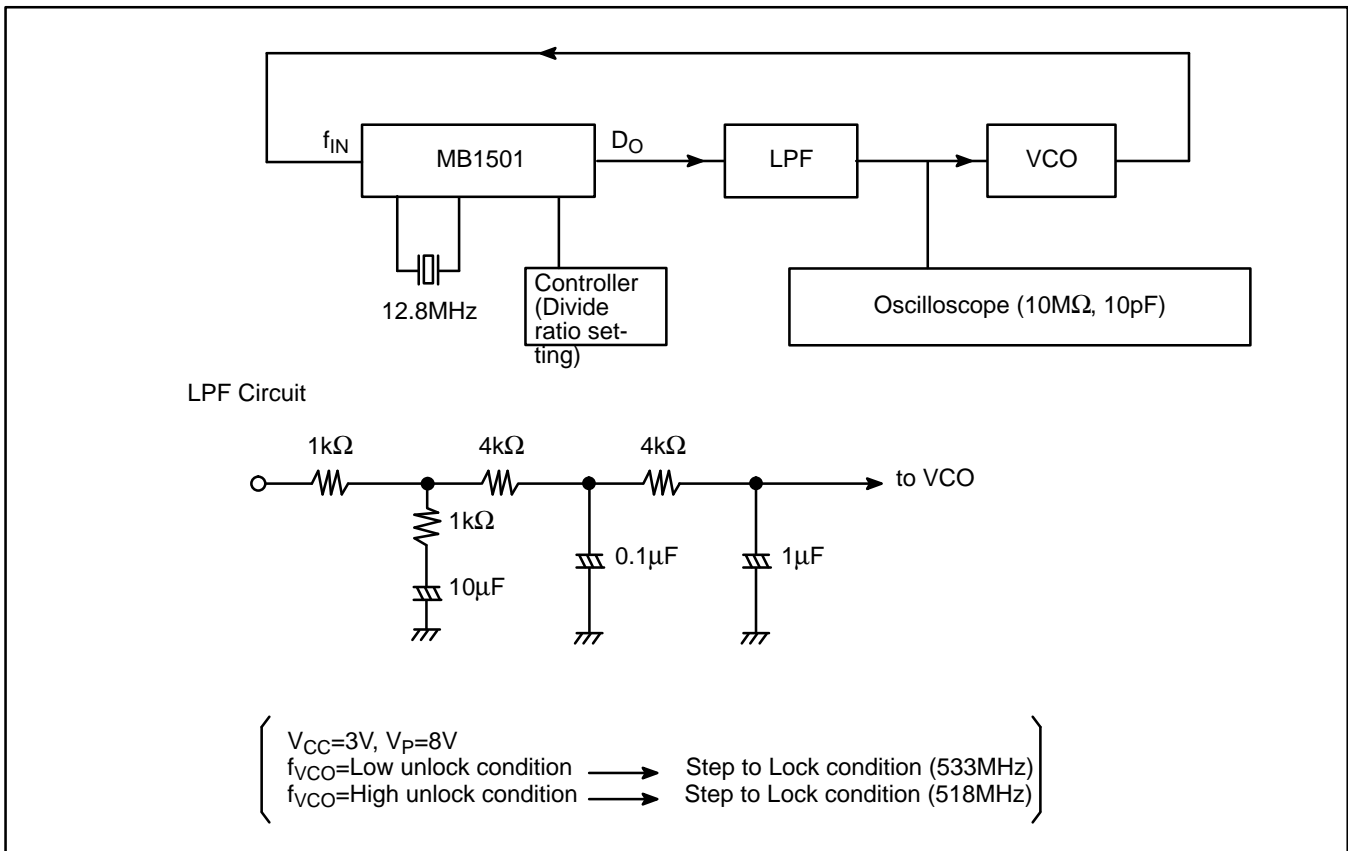

Phase Characteristics Measurement

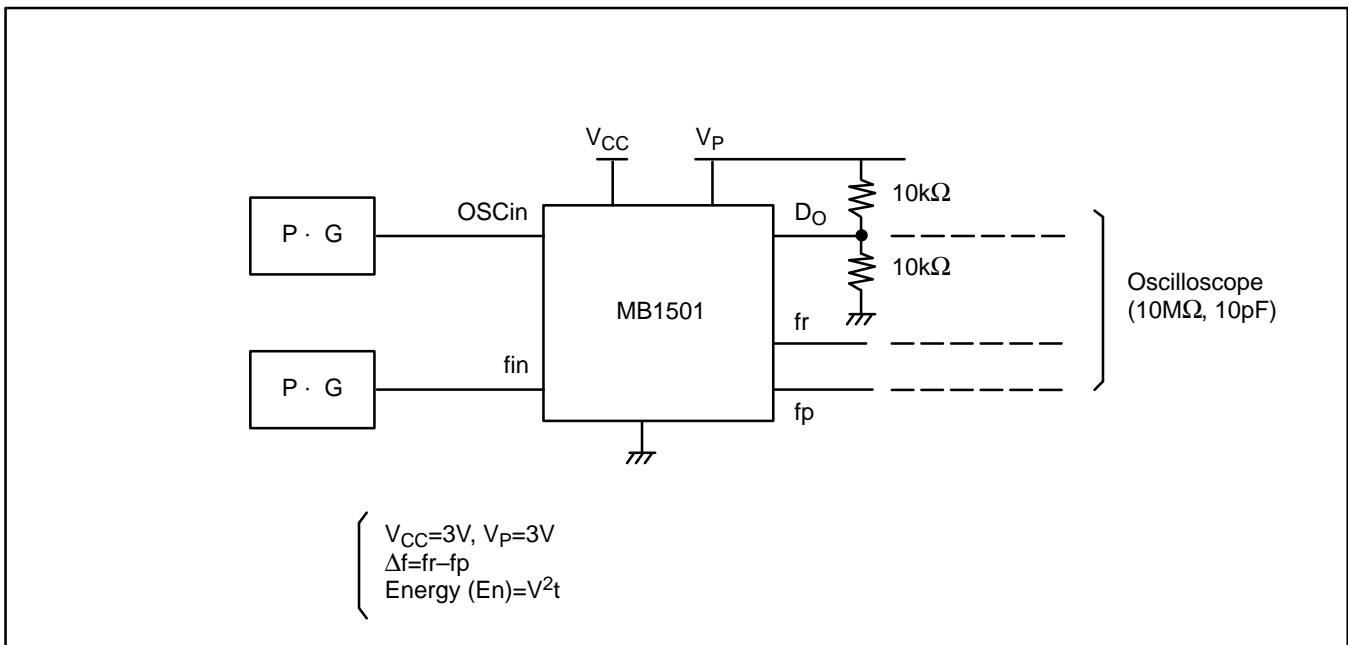

TYPICAL APPLICATION EXAMPLE

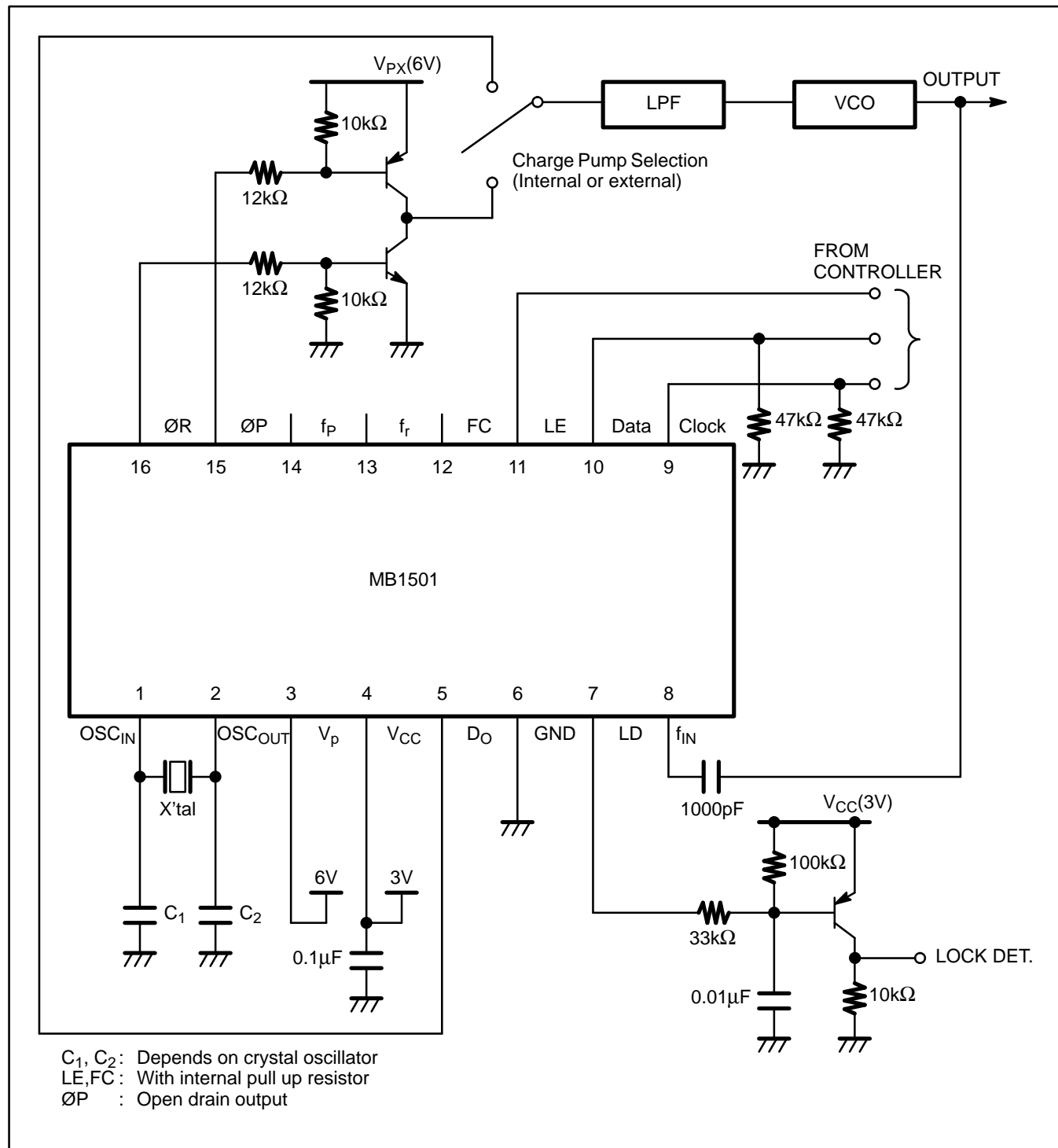

MB1501
MB1501H
MB1501L

PACKAGE DIMENSIONS

16-LEAD PLASTIC DUAL IN-LINE PACKAGE
(Case No.: DIP-16P-M04)

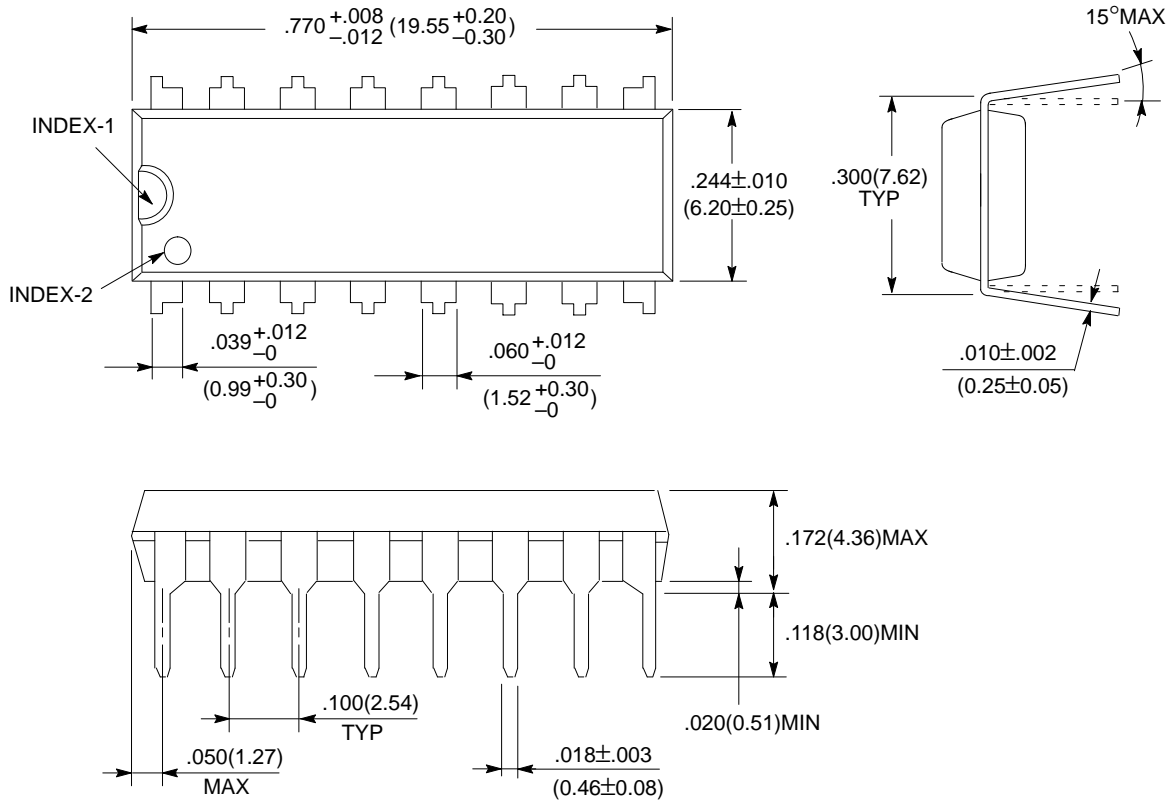

©1991 FUJITSU LIMITED D16033S-2C

Dimensions in
inches (millimeters)

PACKAGE DIMENSIONS

16-LEAD PLASTIC FLAT PACKAGE (Case No.: FPT-16P-M06)

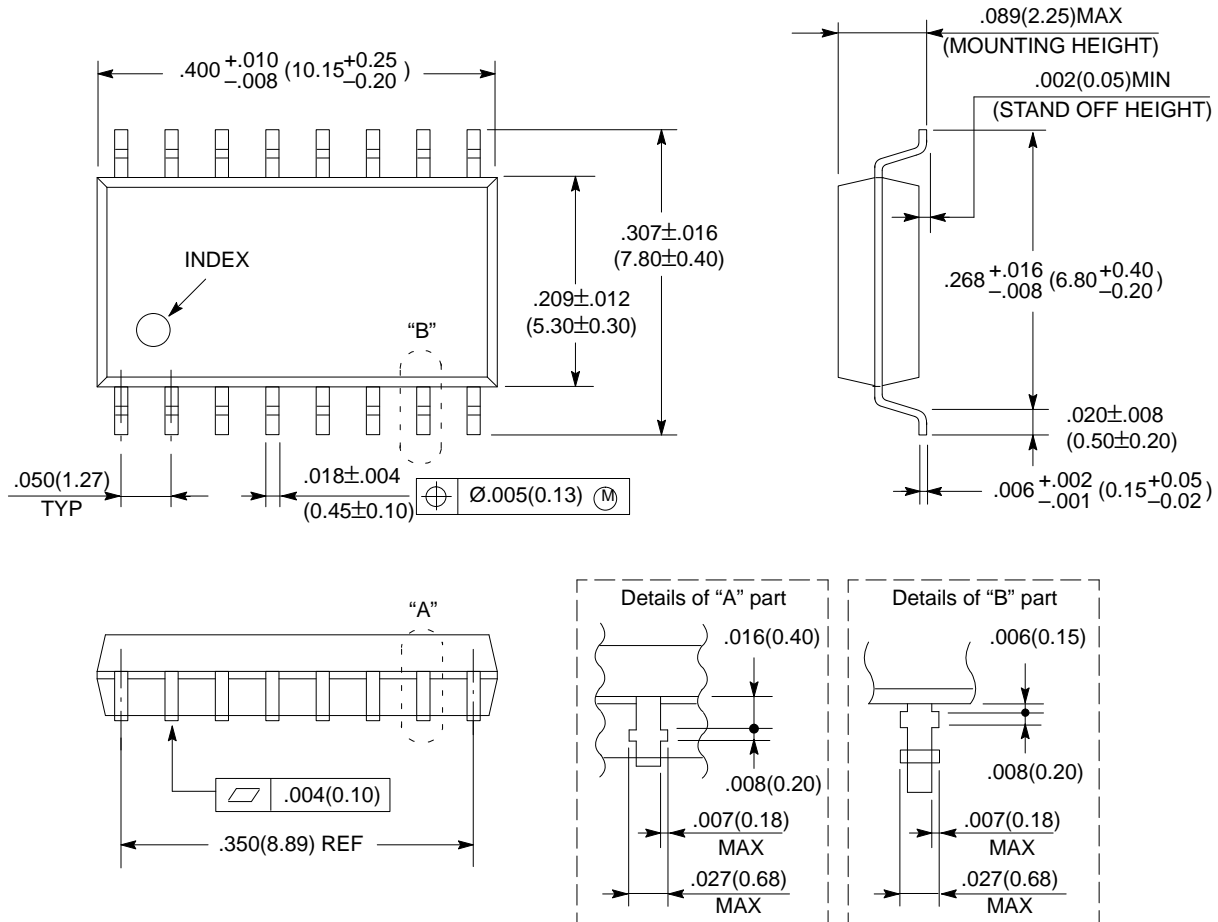

©1991 FUJITSU LIMITED F16015S-2C

Dimensions in inches (millimeters)