

Plug-In

Frequency Mixer

RAY-3

Level 23 (LO Power +23 dBm) 0.07 to 200 MHz



CASE STYLE: A01

Maximum Ratings

Operating Temperature	-55°C to 100°C
Storage Temperature	-55°C to 100°C
RF Power	350mW
IF Current	40mA

Pin Connections

LO	8
RF	1
IF	3,4 [^]
GROUND	2,5,6,7
CASE GROUND	2

[^]pins must be connected together externally

Features

- excellent conversion loss, 5.53 dB typ.
- high isolation 40 dB typ. L-R & L-I
- rugged welded construction
- hermetically sealed

Applications

- VHF
- defense & federal communications
- aviation & maritime communications

Electrical Specifications

FREQUENCY (MHz)		CONVERSION LOSS (dB)				LO-RF ISOLATION (dB)						LO-IF ISOLATION (dB)					
LO/RF f_L - f_U	IF	Mid-Band m		Total Range Max.	8.0	L		M		U		L		M		U	
		\bar{X}	σ			Max.	Typ.	Min.	Typ.	Min.	Typ.	Min.	Typ.	Min.	Typ.	Min.	Typ.
0.07-200	DC-200	5.53	0.08	7.5	8.0	55	45	40	30	30	25	55	45	40	30	30	20

1 dB COMP.: +15 dBm typ.

L = low range [f_L to $10 f_L$]

M = mid range [$10 f_L$ to $f_U/2$]

U = upper range [$f_U/2$ to f_U]

m = mid band [$2f_L$ to $f_U/2$]

Outline Drawing

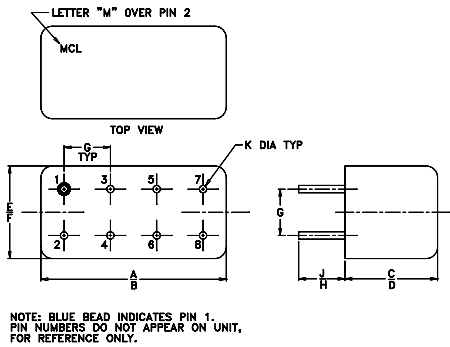

Outline Dimensions (inch/mm)

A	B	C	D	E	F	
.770	.800	.385	.400	.370	.400	
19.56	20.32	9.78	10.16	9.40	10.16	
G	H	J	K		wt	
.200	.20	.14	.031		grams	
5.08	5.08	3.56	0.79		5.2	

Typical Performance Data

Frequency (MHz)		Conversion Loss (dB)	Isolation L-R (dB)	Isolation L-I (dB)	VSWR RF Port (:1)	VSWR LO Port (:1)
RF	LO	LO +23dBm	LO +23dBm	LO +23dBm	LO +23dBm	LO +23dBm
0.07	30.07	5.77	55.55	56.68	1.17	2.42
0.20	30.20	5.58	53.15	57.09	1.18	2.40
1.00	31.00	5.29	52.74	57.07	1.18	2.23
5.00	35.00	5.23	52.57	56.88	1.17	2.21
20.00	50.00	5.27	52.28	56.59	1.17	2.19
34.54	64.54	5.24	51.27	54.69	1.16	2.20
48.33	78.33	5.26	48.91	51.06	1.15	2.20
62.12	92.12	5.28	46.28	47.85	1.15	2.27
69.01	99.01	5.29	44.38	45.65	1.14	2.27
82.80	52.80	5.28	42.67	43.88	1.13	2.28
96.59	66.59	5.28	41.29	41.90	1.13	2.25
103.48	73.48	5.25	39.95	40.89	1.13	2.14
117.27	87.27	5.28	39.22	39.90	1.12	2.10
131.06	101.06	5.29	39.37	39.78	1.12	2.17
144.85	114.85	5.34	38.04	37.10	1.12	2.25
158.63	128.63	5.43	36.70	33.79	1.12	2.29
165.53	135.53	5.47	36.49	31.41	1.13	2.22
179.32	149.32	5.47	36.22	30.50	1.14	2.16
193.10	163.10	5.54	36.47	29.43	1.16	2.18
200.00	170.00	5.51	36.43	29.00	1.16	2.21

Electrical Schematic

