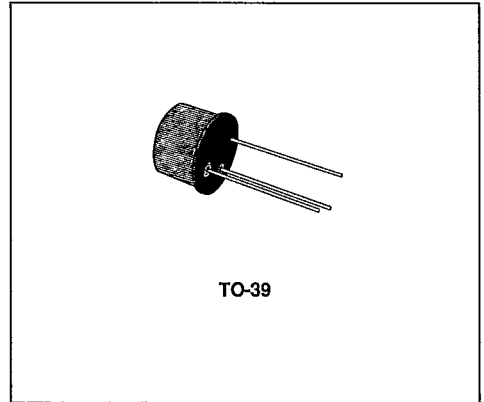
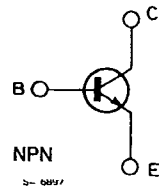

SWITCHES AND UNIVERSAL AMPLIFIERS
DESCRIPTION

The 2N1613 and 2N1711 are silicon planar epitaxial NPN transistors in Jedec TO-39 metal case. They are designed for use in high-performance amplifier, oscillator and switching circuits.

The 2N1711 is also used to advantage in amplifiers where low noise is an important factor.

 Products approved to CECC 50002-104 available on request.

INTERNAL SCHEMATIC DIAGRAM

ABSOLUTE MAXIMUM RATINGS

Symbol	Parameter	Value	Unit
V_{CBO}	Collector-base Voltage ($I_E = 0$)	75	V
V_{CER}	Collector-emitter Voltage ($R_{BE} \leq 10 \Omega$)	50	V
V_{EBO}	Emitter-base Voltage ($I_C = 0$)	7	V
I_C	Collector Current	500	mA
P_{tot}	Total Power Dissipation at $T_{amb} \leq 25^\circ C$	0.8	W
	at $T_{case} \leq 25^\circ C$	3	W
	at $T_{case} \leq 100^\circ C$	1.7	W
T_{stg}, T_J	Storage and Junction Temperature	- 65 to 200	$^\circ C$

THERMAL DATA

$R_{th\ j-case}$	Thermal Resistance Junction-case	Max	58	°C/W
$R_{th\ j-amb}$	Thermal Resistance Junction-ambient	Max	219	°C/W

ELECTRICAL CHARACTERISTICS ($T_{amb} = 25\text{ °C}$ unless otherwise specified)

Symbol	Parameter	Test Conditions		Min.	Typ.	Max.	Unit
I_{CBO}	Collector Cutoff Current ($I_E = 0$)	$V_{CB} = 60\text{ V}$				10	nA
		$V_{CB} = 60\text{ V}$	$T_{amb} = 150\text{ °C}$			10	μA
I_{EBO}	Emitter Cutoff Current ($I_C = 0$)	$V_{EB} = 5\text{ V}$	for 2N1613 for 2N1711			10 5	nA nA
$V_{(BR)\ CBO}$	Collector-base Breakdown Voltage	$I_C = 0.1\text{ mA}$		75			V
$V_{(BR)\ CER}^*$	Collector-emitter Breakdown Voltage ($R_{BE} \leq 10\ \Omega$)	$I_C = 10\text{ mA}$		50			V
$V_{(BR)\ EBO}$	Emitter-base Breakdown Voltage ($I_C = 0$)	$I_E = 0.1\text{ mA}$		7			V
$V_{CE(sat)}^*$	Collector-emitter Saturation Voltage	$I_C = 150\text{ mA}$	$I_B = 15\text{ mA}$		0.5	1.5	V
$V_{BE(sat)}^*$	Base-emitter Saturation Voltage	$I_C = 150\text{ mA}$	$I_B = 15\text{ mA}$		0.95	1.3	V
h_{FE}^*	DC Current Gain	for 2N1613					
		$I_C = 0.01\text{ mA}$	$V_{CE} = 10\text{ V}$		35		
		$I_C = 0.1\text{ mA}$	$V_{CE} = 10\text{ V}$	20	50		
		$I_C = 10\text{ mA}$	$V_{CE} = 10\text{ V}$	35	80		
		$I_C = 150\text{ mA}$	$V_{CE} = 10\text{ V}$	40	80	120	
		$I_C = 500\text{ mA}$	$V_{CE} = 10\text{ V}$	20	55		
		$I_C = 10\text{ mA}$	$V_{CE} = 10\text{ V}$	20	35		
		$T_{amb} = -55\text{ °C}$					
h_{FE}^*	DC Current Gain	for 2N1711					
		$I_C = 0.01\text{ mA}$	$V_{CE} = 10\text{ V}$	20	60		
		$I_C = 0.1\text{ mA}$	$V_{CE} = 10\text{ V}$	35	80		
		$I_C = 10\text{ mA}$	$V_{CE} = 10\text{ V}$		130		
		$I_C = 150\text{ mA}$	$V_{CE} = 10\text{ V}$		130	300	
		$I_C = 500\text{ mA}$	$V_{CE} = 10\text{ V}$		75		
		$I_C = 10\text{ mA}$	$V_{CE} = 10\text{ V}$		65		
		$T_{amb} = 55\text{ °C}$					
h_{fe}	Small Signal Current Gain	for 2N1613					
		$I_C = 1\text{ mA}$ $f = 1\text{ kHz}$	$V_{CE} = 10\text{ V}$	30	70	150	
		for 2N1711					
		$I_C = 1\text{ mA}$ $f = 1\text{ kHz}$	$V_{CE} = 10\text{ V}$	70	135	300	
f_t	Transition Frequency	$I_C = 50\text{ mA}$	$V_{CE} = 10\text{ V}$	60	80		MHz
		$f = 20\text{ MHz}$	for 2N1613 for 2N1711	70	100		
C_{EBO}	Emitter-base Capacitance	$I_C = 0$ $f = 1\text{ MHz}$	$V_{EB} = 0.5\text{ V}$		50	80	pF
C_{CBO}	Collector-base Capacitance	$I_E = 0$ $f = 1\text{ MHz}$	$V_{CB} = 10\text{ V}$		18	25	pF

* Pulsed : pulse duration = 300 μs , duty cycle = 1 %.

ELECTRICAL CHARACTERISTICS (continued)

T-35-19

Symbol	Parameter	Test Conditions		Min.	Typ.	Max.	Unit
NF	Noise Figure	$I_C = 0.3 \text{ mA}$ $R_g = 510 \Omega$	$V_{CE} = 10 \text{ V}$ $f = 1 \text{ kHz}$ for 2N1613 for 2N1711		6 3.5	12 8	dB dB
h_{ie}	Input Impedance	$I_C = 1 \text{ mA}$ $f = 1 \text{ kHz}$	$V_{CE} = 5 \text{ V}$ for 2N1613 for 2N1711		2.2 4.4		k Ω k Ω
h_{re}	Reverse Voltage Ratio	$I_C = 1 \text{ mA}$ $f = 1 \text{ kHz}$	$V_{CE} = 5 \text{ V}$ for 2N1613 for 2N1711		3.6×10^{-4} 7.3×10^{-4}		
h_{oe}	Output Admittance	$I_C = 1 \text{ mA}$ $f = 1 \text{ kHz}$	$V_{CE} = 5 \text{ V}$ for 2N1613 for 2N1711		12.5 23.8		μS μS

* Pulsed : pulse duration = 300 μs , duty cycle = 1 %.