



Up to 6 GHz Low Noise Silicon Bipolar Transistor

Technical Data

AT-41410

Features

- **Low Noise Figure:**
1.6 dB Typical at 2.0 GHz
3.0 dB Typical at 4.0 GHz
- **High Associated Gain:**
14.0 dB Typical at 2.0 GHz
10.0 dB Typical at 4.0 GHz
- **High Gain-Bandwidth**
Product: 8.0 GHz Typical f_T
- **Hermetic, Gold-ceramic
Microstrip Package**

Description

Agilent's AT-41410 is a general purpose NPN bipolar transistor that offers excellent high frequency performance. The AT-41410 is housed in a hermetic, high reliability 100 mil ceramic package. The 4 micron emitter-to-emitter pitch enables this transistor to be used in many different functions. The 14 emitter finger

interdigitated geometry yields an intermediate sized transistor with impedances that are easy to match for low noise and moderate power applications. This device is designed for use in low noise, wideband amplifier, mixer and oscillator applications in the VHF, UHF, and microwave frequencies. An optimum noise match near 50Ω at 1 GHz, makes this device easy to use as a low noise amplifier.

The AT-41410 bipolar transistor is fabricated using Agilent's 10 GHz f_T Self-Aligned-Transistor (SAT) process. The die is nitride passivated for surface protection. Excellent device uniformity, performance and reliability are produced by the use of ion-implantation, self-alignment techniques, and gold metalization in the fabrication of this device.

100 mil Package

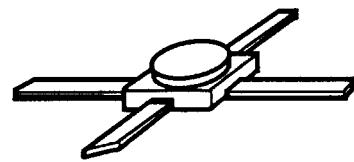

AT-41410 Absolute Maximum Ratings

Symbol	Parameter	Units	Absolute Maximum ^[1]
V _{EBO}	Emitter-Base Voltage	V	1.5
V _{CBO}	Collector-Base Voltage	V	20
V _{CEO}	Collector-Emitter Voltage	V	12
I _C	Collector Current	mA	60
P _T	Power Dissipation ^[2,3]	mW	500
T _j	Junction Temperature	°C	200
T _{STG}	Storage Temperature	°C	-65 to 200

Thermal Resistance^[2,4]:

$$\theta_{jc} = 170^{\circ}\text{C/W}$$

Notes:

1. Permanent damage may occur if any of these limits are exceeded.
2. T_{CASE} = 25°C.
3. Derate at 5.9 mW/°C for T_C > 115°C.
4. The small spot size of this technique results in a higher, though more accurate determination of θ_{jc} than do alternate methods. See MEASUREMENTS section "Thermal Resistance" for more information.

Electrical Specifications, T_A = 25°C

Symbol	Parameters and Test Conditions	Units	Min.	Typ.	Max.
S _{21E} ²	Insertion Power Gain; V _{CE} = 8 V, I _C = 25 mA	f = 2.0 GHz f = 4.0 GHz	dB	12.0 6.5	
P _{1dB}	Power Output @ 1 dB Gain Compression V _{CE} = 8 V, I _C = 25 mA	f = 2.0 GHz f = 4.0 GHz	dBm	19.0 18.5	
G _{1dB}	1 dB Compressed Gain; V _{CE} = 8 V, I _C = 25 mA	f = 2.0 GHz f = 4.0 GHz	dB	14.0 9.5	
NF _O	Optimum Noise Figure; V _{CE} = 8 V, I _C = 10 mA	f = 1.0 GHz f = 2.0 GHz f = 4.0 GHz	dB	1.3 1.6 3.0	1.9
G _A	Gain @ NF _O ; V _{CE} = 8 V, I _C = 10 mA	f = 1.0 GHz f = 2.0 GHz f = 4.0 GHz	dB	13.0 18.5 14.0 10.0	
f _T	Gain Bandwidth Product; V _{CE} = 8 V, I _C = 25 mA		GHz	8.0	
h _{FE}	Forward Current Transfer Ratio; V _{CE} = 8 V, I _C = 10 mA		—	30	270
I _{CBO}	Collector Cutoff Current; V _{CB} = 8 V		μA		0.2
I _{EBO}	Emitter Cutoff Current; V _{EB} = 1 V		μA		1.0
C _{CB}	Collector Base Capacitance ^[1] ; V _{CB} = 8 V, f = 1 MHz		pF	0.2	

Notes:

1. For this test, the emitter is grounded.

AT-41410 Typical Performance, $T_A = 25^\circ\text{C}$

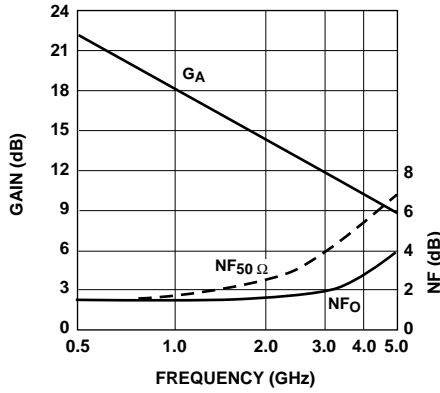

Figure 1. Noise Figure and Associated Gain vs. Frequency.
 $V_{CE} = 8\text{ V}$, $I_C = 10\text{ mA}$.

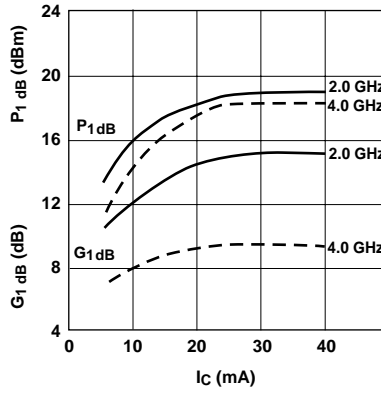

Figure 2. Output Power and 1 dB Compressed Gain vs. Collector Current and Frequency. $V_{CE} = 8\text{ V}$.

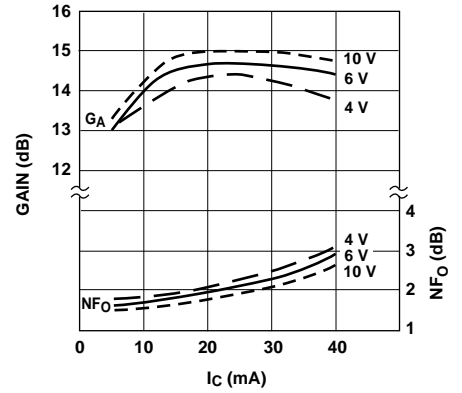

Figure 3. Optimum Noise Figure and Associated Gain vs. Collector Current and Collector Voltage. $f = 2.0\text{ GHz}$.

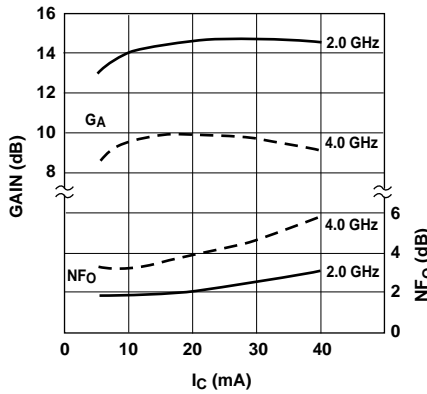

Figure 4. Optimum Noise Figure and Associated Gain vs. Collector Current and Frequency. $V_{CE} = 8\text{ V}$.

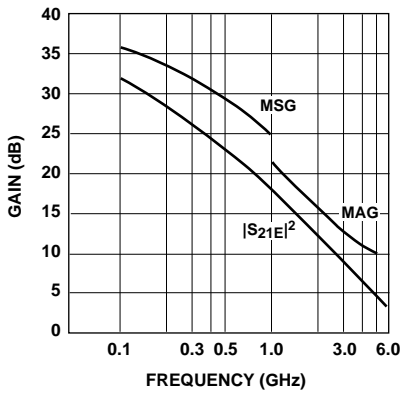

Figure 5. Insertion Power Gain, Maximum Available Gain and Maximum Stable Gain vs. Frequency.
 $V_{CE} = 8\text{ V}$, $I_C = 25\text{ mA}$.

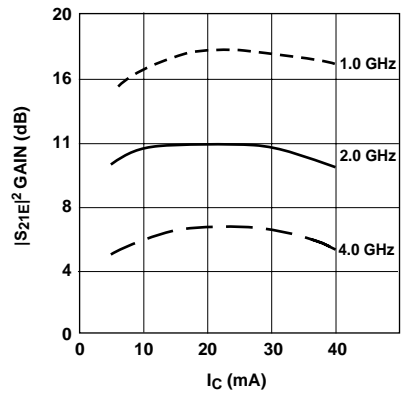

Figure 6. Insertion Power Gain vs. Collector Current and Frequency. $V_{CE} = 8\text{ V}$.

AT-41410 Typical Scattering Parameters,Common Emitter, $Z_O = 50 \Omega$, $T_A = 25^\circ\text{C}$, $V_{CE} = 8 \text{ V}$, $I_C = 10 \text{ mA}$

Freq. GHz	S_{11}		S_{21}			S_{12}			S_{22}	
	Mag.	Ang.	dB	Mag.	Ang.	dB	Mag.	Ang.	Mag.	Ang.
0.1	.61	-40	27.7	24.38	159	-40.0	.010	75	.94	-13
0.5	.60	-127	22.2	12.83	110	-30.4	.030	40	.62	-33
1.0	.60	-163	17.1	7.12	86	-28.2	.039	35	.50	-38
1.5	.60	179	13.8	4.89	71	-27.5	.042	45	.46	-42
2.0	.61	165	11.4	3.72	59	-26.0	.050	42	.45	-48
2.5	.61	157	9.7	3.04	52	-24.7	.058	46	.44	-52
3.0	.62	149	8.2	2.56	42	-23.9	.064	50	.44	-58
3.5	.63	140	7.0	2.23	31	-22.3	.077	48	.46	-68
4.0	.62	130	5.9	1.96	20	-21.3	.086	44	.48	-78
4.5	.61	120	4.9	1.76	10	-20.4	.095	41	.50	-85
5.0	.61	106	4.0	1.59	-1	-18.9	.113	38	.52	-91
5.5	.62	94	3.2	1.45	-11	-18.3	.121	33	.52	-97
6.0	.66	82	2.4	1.31	-22	-17.5	.133	30	.51	-105

AT-41410 Typical Scattering Parameters,Common Emitter, $Z_O = 50 \Omega$, $T_A = 25^\circ\text{C}$, $V_{CE} = 8 \text{ V}$, $I_C = 25 \text{ mA}$

Freq. GHz	S_{11}		S_{21}			S_{12}			S_{22}	
	Mag.	Ang.	dB	Mag.	Ang.	dB	Mag.	Ang.	Mag.	Ang.
0.1	.45	-69	31.4	37.17	150	-39.2	.011	64	.87	-18
0.5	.58	-153	23.3	14.63	101	-33.6	.021	43	.49	-33
1.0	.59	-178	17.7	7.68	81	-30.4	.030	53	.43	-35
1.5	.60	169	14.3	5.21	68	-28.2	.039	58	.41	-40
2.0	.60	157	11.9	3.94	56	-25.8	.051	55	.41	-45
2.5	.61	151	10.1	3.20	50	-24.4	.060	55	.40	-49
3.0	.62	144	8.6	2.70	40	-23.1	.070	58	.40	-56
3.5	.63	135	7.4	2.35	30	-21.9	.080	54	.42	-66
4.0	.62	126	6.3	2.07	19	-20.5	.094	53	.44	-76
4.5	.61	116	5.3	1.85	9	-19.3	.108	45	.46	-84
5.0	.61	103	4.5	1.67	-2	-18.5	.119	41	.49	-90
5.5	.63	91	3.6	1.52	-12	-17.6	.131	34	.49	-96
6.0	.67	80	2.8	1.37	-22	-16.8	.144	29	.47	-104

A model for this device is available in the DEVICE MODELS section.

AT-41410 Noise Parameters: $V_{CE} = 8 \text{ V}$, $I_C = 10 \text{ mA}$

Freq. GHz	N_{F0} dB	Γ_{opt}		$R_N/50$
		Mag	Ang	
0.1	1.2	.12	4	0.17
0.5	1.2	.10	23	0.17
1.0	1.3	.06	49	0.16
2.0	1.6	.26	172	0.16
4.0	3.0	.46	-133	0.26

100 mil Package Dimensions

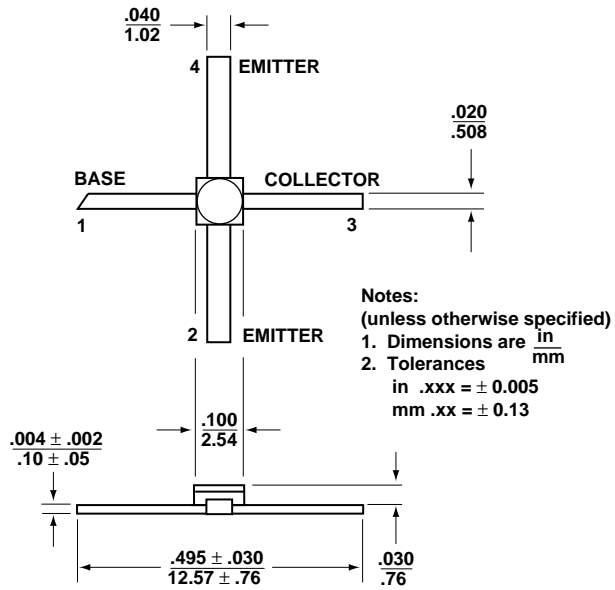



Agilent Technologies

Innovating the HP Way

www.semiconductor.agilent.com

Data subject to change.

Copyright © 1999 Agilent Technologies

5965-8923E (11/99)