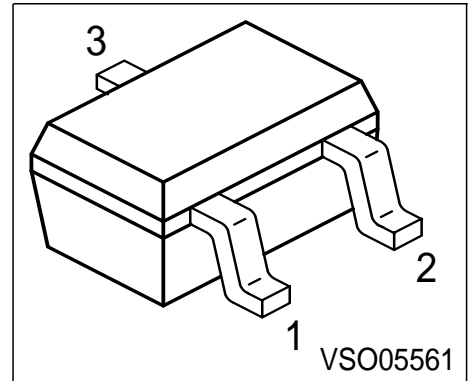
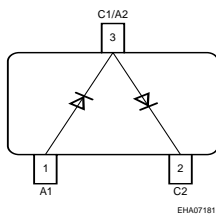
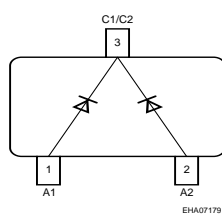
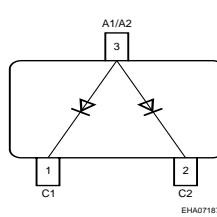

Silicon PIN Diode

- PIN diode for high speed switching of RF signal
- Low forward resistance
- Very low capacitance
- For frequencies up to 3 GHz

BAR63-04W

BAR63-05W

BAR63-06W

Type	Marking	Pin Configuration			Package
BAR63-04W	G4s	1 = A1	2 = C2	3=C1/A2	SOT323
BAR63-05W	G5s	1 = A1	2 = A2	3 = C1/2	SOT323
BAR63-06W	G6s	1 = C1	2 = C2	3 = A1/2	SOT323

Maximum Ratings

Parameter	Symbol	Value	Unit
Diode reverse voltage	V_R	50	V
Forward current	I_F	100	mA
Total power dissipation, $T_S \leq 105\text{ °C}$	P_{tot}	250	mW
Junction temperature	T_j	150	°C
Operating temperature range	T_{op}	-55 ... 150	
Storage temperature	T_{stg}	-55 ... 150	

Thermal Resistance

Junction - soldering point ¹⁾	R_{thJS}	≤ 180	K/W
--	------------	------------	-----

¹⁾For calculation of R_{thJA} please refer to Application Note Thermal Resistance

Electrical Characteristics at $T_A = 25^\circ\text{C}$, unless otherwise specified.

Parameter	Symbol	Values			Unit
		min.	typ.	max.	
DC characteristics					
Breakdown voltage $I_{(BR)} = 5 \mu\text{A}$	$V_{(BR)}$	50	-	-	V
Reverse current $V_R = 20 \text{ V}$	I_R	-	-	50	nA
Forward voltage $I_F = 100 \text{ mA}$	V_F	-	0.95	1.2	V
AC characteristics					
Diode capacitance $V_R = 0 \text{ V}, f = 100 \text{ MHz}$ $V_R = 5 \text{ V}, f = 1 \text{ MHz}$	C_T	- -	0.3 0.21	- 0.3	pF
Forward resistance $I_F = 5 \text{ mA}, f = 100 \text{ MHz}$ $I_F = 10 \text{ mA}, f = 100 \text{ MHz}$	r_f	- -	1.2 1	2 -	Ω
Charge carrier life time $I_F = 10 \text{ mA}, I_R = 6 \text{ mA}, I_R = 3 \text{ mA}$	τ_{rr}	-	75	-	ns
Series inductance	L_S	-	1.4	-	nH

Forward current $I_F = f(T_S)$

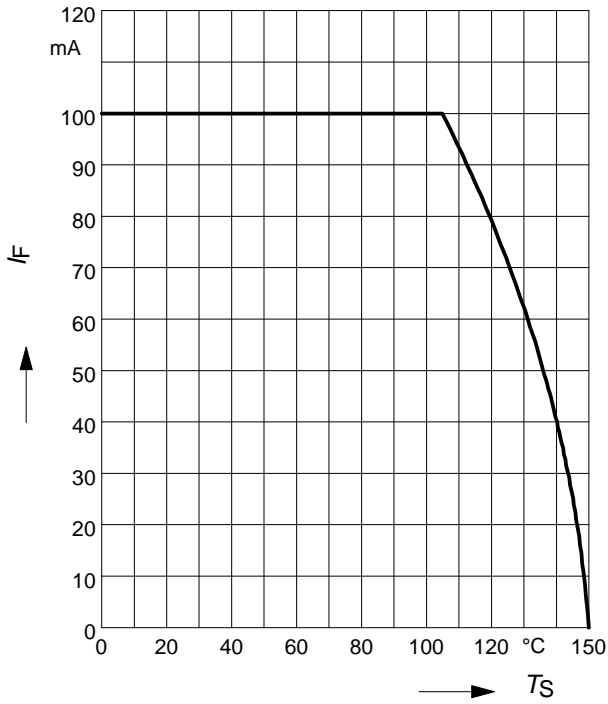

Permissible Pulse Load $R_{thJS} = f(t_p)$

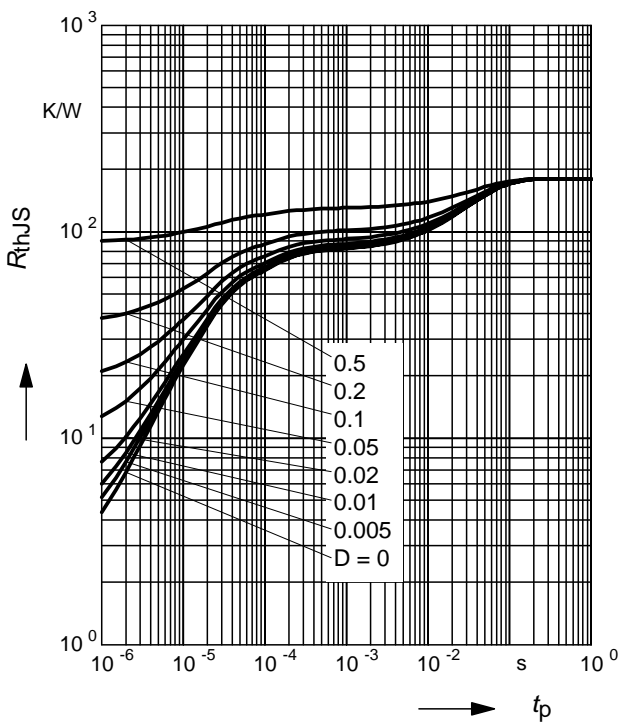

Permissible Pulse Load

$I_{Fmax} / I_{FDC} = f(t_p)$

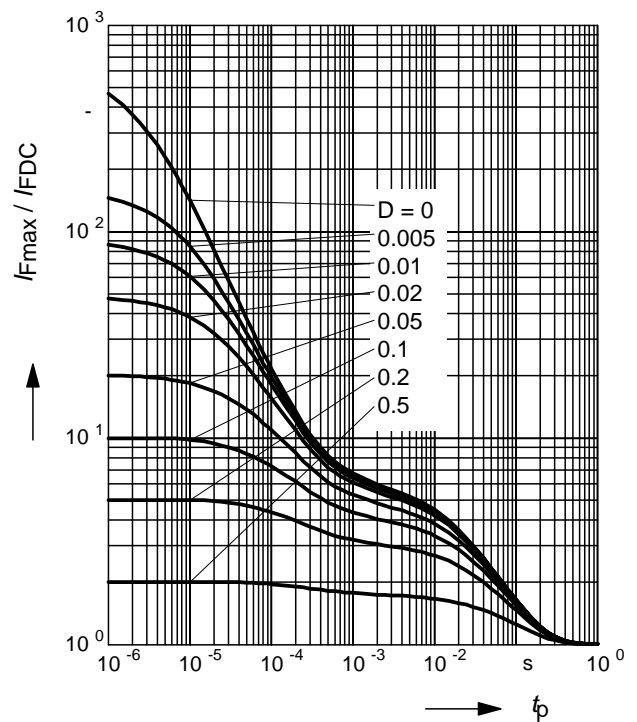

Diode capacitance $C_T = f(V_R)$

$f = 1\text{MHz}$

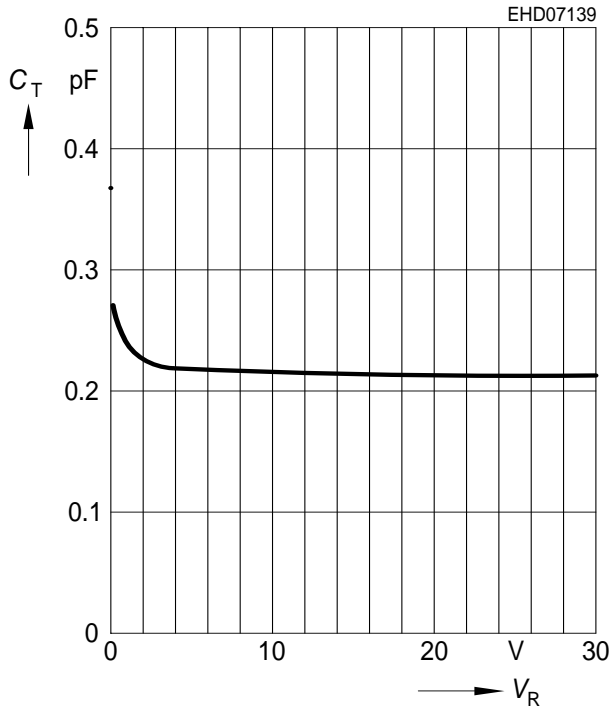

Forward resistance $r_f = f(I_F)$

$f = 100\text{MHz}$

