

# Package / Tape and Reel Drawings

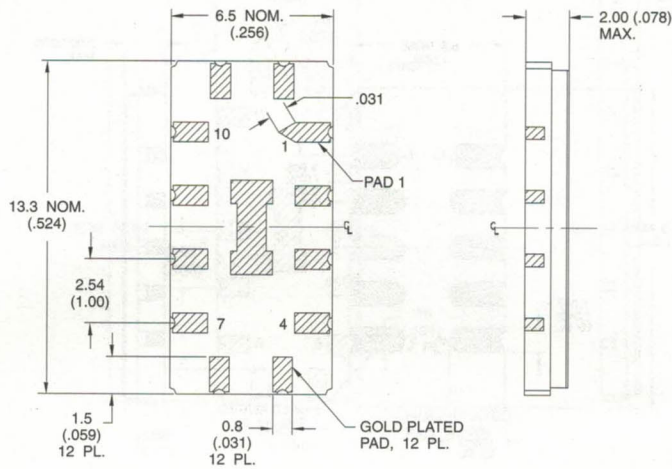

PAD 11 IS THE RECOMMENDED INPUT.  
PAD 12 IS THE RECOMMENDED INPUT RETURN.

PAD 5 IS THE RECOMMENDED OUTPUT.  
PAD 6 IS THE RECOMMENDED OUTPUT RETURN.

PADS 2, 3, 8 AND 9 ARE CASE GROUND.

DIMENSIONS ARE NOMINAL IN MILLIMETERS (INCHES)  
(SUBJECT TO CHANGE AT SAWTEK DISCRETION)

## SMP-53

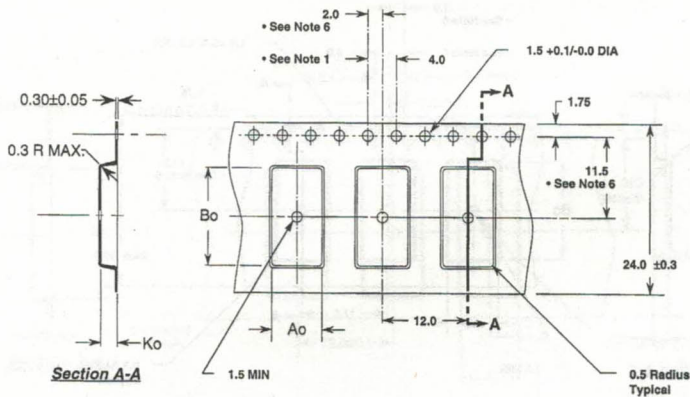

Ao = 7.1 mm  
Bo = 13.9 mm  
Ko = 2.3 mm

## Tape and Reel Drawing for SMP-53

### Notes

1. 10 sprocket hole pitch cumulative tolerance  $\pm 0.2$
2. Camber not to exceed 1mm in 100mm
3. Material: Black conductive polystyrene
4. Ao and Bo measured on a plane 0.3mm above the bottom of the sprocket
5. Ko measured from a plane on the inside bottom of the pocket to the top surface of the carrier
6. Pocket position relative to sprocket hole measured as true position of pocket, not pocket hole

Note: The recommended pinout may be different on some filters that are used for specific applications.