

DATA SHEET

BGY43

VHF power amplifier module

Product specification

Supersedes data of May 1991

File under Discrete Semiconductors, SC09

1996 Jun 06

VHF power amplifier module

BGY43

FEATURES

- Broadband VHF amplifier
- 13 W output power
- Direct operation from 12 V vehicle electrical systems

APPLICATIONS

- Mobile communication equipment operating in the 148 to 174 MHz frequency range.

PINNING - SOT132B

PIN	DESCRIPTION
1	RF input
2	ground
3	V _{S1}
4	ground
5	V _{S2}
6	ground
7	RF output
Flange	ground

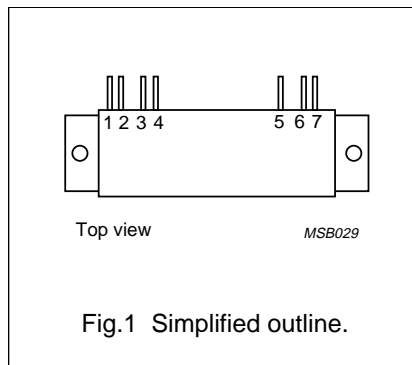

DESCRIPTION

The BGY43 is a two-stage amplifier module in a SOT132B package. The module consists of a two stage RF amplifier using NPN silicon planar transistor dies with lumped-element matching components, in a plastic stripline encapsulation. The negative supply is internally connected to the flange.

QUICK REFERENCE DATA

RF performance at T_h = 25 °C.

MODE OF OPERATION	f (MHz)	V _{S1} ; V _{S2} (V)	P _D (mW)	P _L (W)	Z _S , Z _L (Ω)
CW	148 to 174	12.5	≤150; typ 80	>13	50

WARNING
Product and environmental safety - toxic materials
This product contains beryllium oxide. The product is entirely safe provided that the BeO disc is not damaged. All persons who handle, use or dispose of this product should be aware of its nature and of the necessary safety precautions. After use, dispose of as chemical or special waste according to the regulations applying at the location of the user. It must never be thrown out with the general or domestic waste.

VHF power amplifier module

BGY43

LIMITING VALUES

In accordance with the Absolute Maximum Rating System (IEC 134).

SYMBOL	PARAMETER	MIN.	MAX.	UNIT
V_{S1}	DC supply voltage	–	16.5	V
V_{S2}	DC supply voltage	–	16.5	V
V_i	RF input terminal voltage	–	± 25	V
V_o	RF output terminal voltage	–	± 25	V
P_D	input drive power	–	300	mW
P_L	load power	–	18	W
T_{stg}	storage temperature	–40	+100	°C
T_h	operating heatsink temperature	–	90	°C

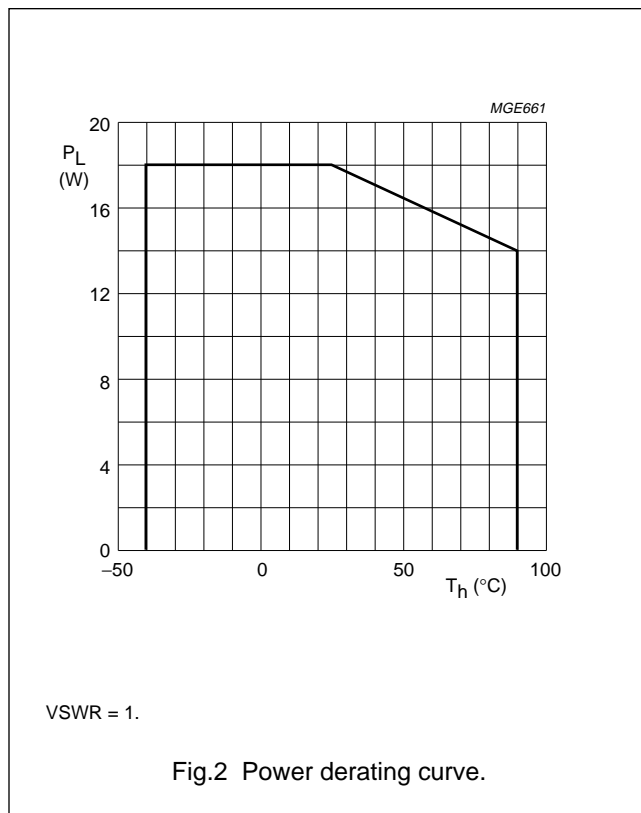

VHF power amplifier module

BGY43

CHARACTERISTICS

$Z_S = Z_L = 50 \Omega$; $V_{S1} = V_{S2} = 12.5 \text{ V}$; $f = 148 \text{ to } 174 \text{ MHz}$; $T_h = 25 \text{ }^\circ\text{C}$; unless otherwise specified.

SYMBOL	PARAMETER	CONDITIONS	MIN.	TYP.	MAX.	UNIT
I_{Q1}	leakage current	$P_D = 0$	–	5	–	mA
I_{Q2}	leakage current	$P_D = 0$	–	15	–	mA
P_D	input drive power	$P_L = 13 \text{ W}$	–	80	150	mW
η	efficiency	$P_L = 13 \text{ W}$	40	48	–	%
H_2	second harmonic		–25	–34	–	dBc
H_3	third harmonic		–25	–34	–	dBc
$V_{SWR_{in}}$	input VSWR	with respect to 50Ω	–	1 : 1.5	–	

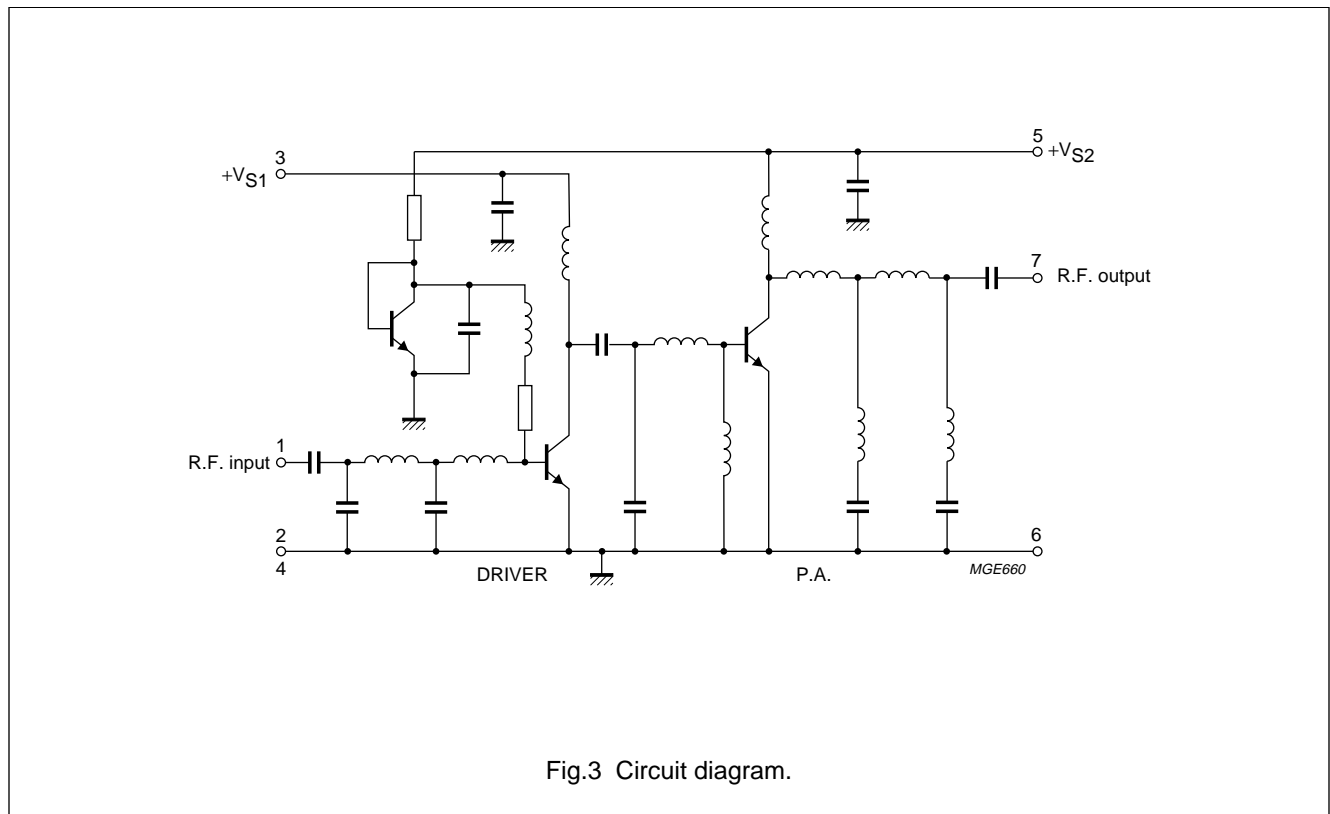

VHF power amplifier module

BGY43

Stability

The module is stable with a load VSWR up to 3:1 (all phases) when operated within the following conditions:
 $V_{S1} = V_{S2} = 10 \text{ V to } 16.5 \text{ V}$; $P_D = 30 \text{ to } 300 \text{ mW}$;
 $f = 148 \text{ to } 174 \text{ MHz}$; $P_L \leq 18 \text{ W}$ (matched).

Ruggedness

The module will withstand a load mismatch VSWR of 50:1 (all phases) for short period overload conditions, with drive power and DC supply voltages at maximum values, providing the combination does not result in the matched RF output power rating being exceeded.

MOUNTING

To ensure good thermal transfer the module should be mounted on a heatsink with a flat surface with heat-conducting compound applied between module and heatsink. If an isolation washer is used, heatsink compound should be applied to both sides of the washer. Burrs and thickening of the holes in the heatsink should be removed and 3 mm bolts tightened to a torque of 0.5 Nm. The leads of the devices may be soldered directly into a circuit using a soldering iron with a maximum temperature of 245 °C for not more than 10 seconds at a distance of at least 1 mm from the plastic.

APPLICATION INFORMATION

Power rating

In general, it is recommended that the output power from the module under nominal conditions should not exceed 16 W in order to provide an adequate safety margin under fault conditions.

Output power control

The module is not designed to be operated over a wide range of output power levels. The purpose of the output power control is to set the nominal output power level. The preferred method of output power control is by varying the drive power between 30 and 200 mW. The next option is by varying V_{S1} between 6 and 12.5 V.

VHF power amplifier module

BGY43

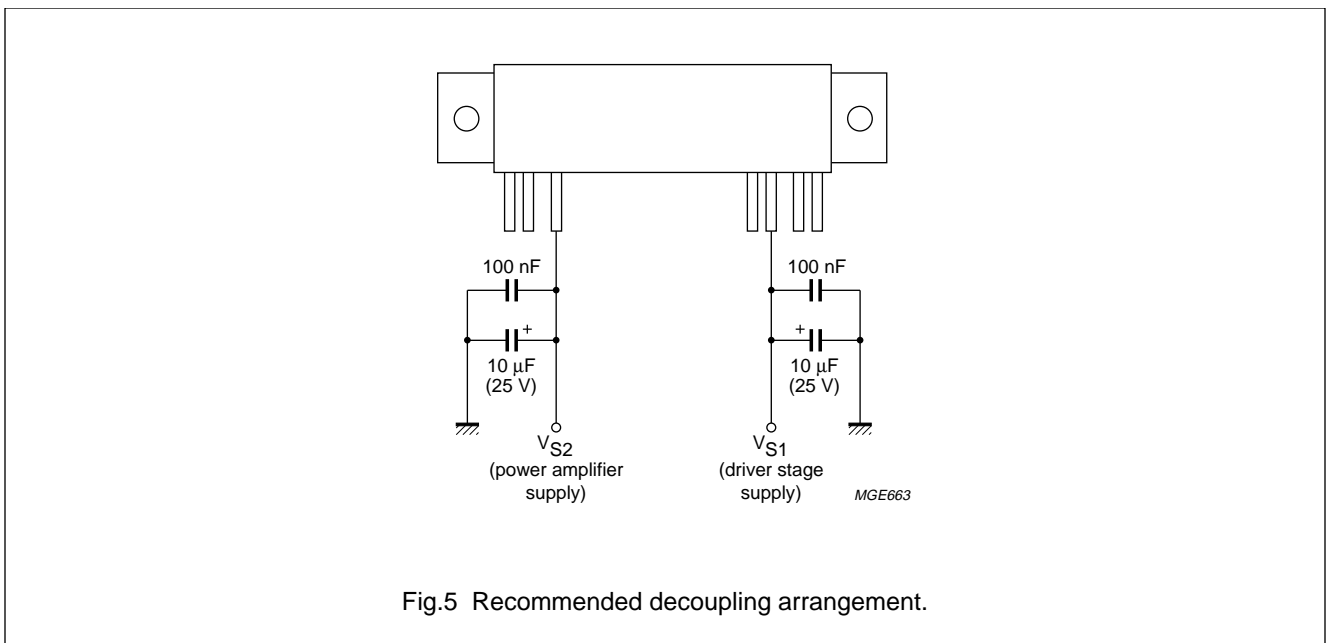
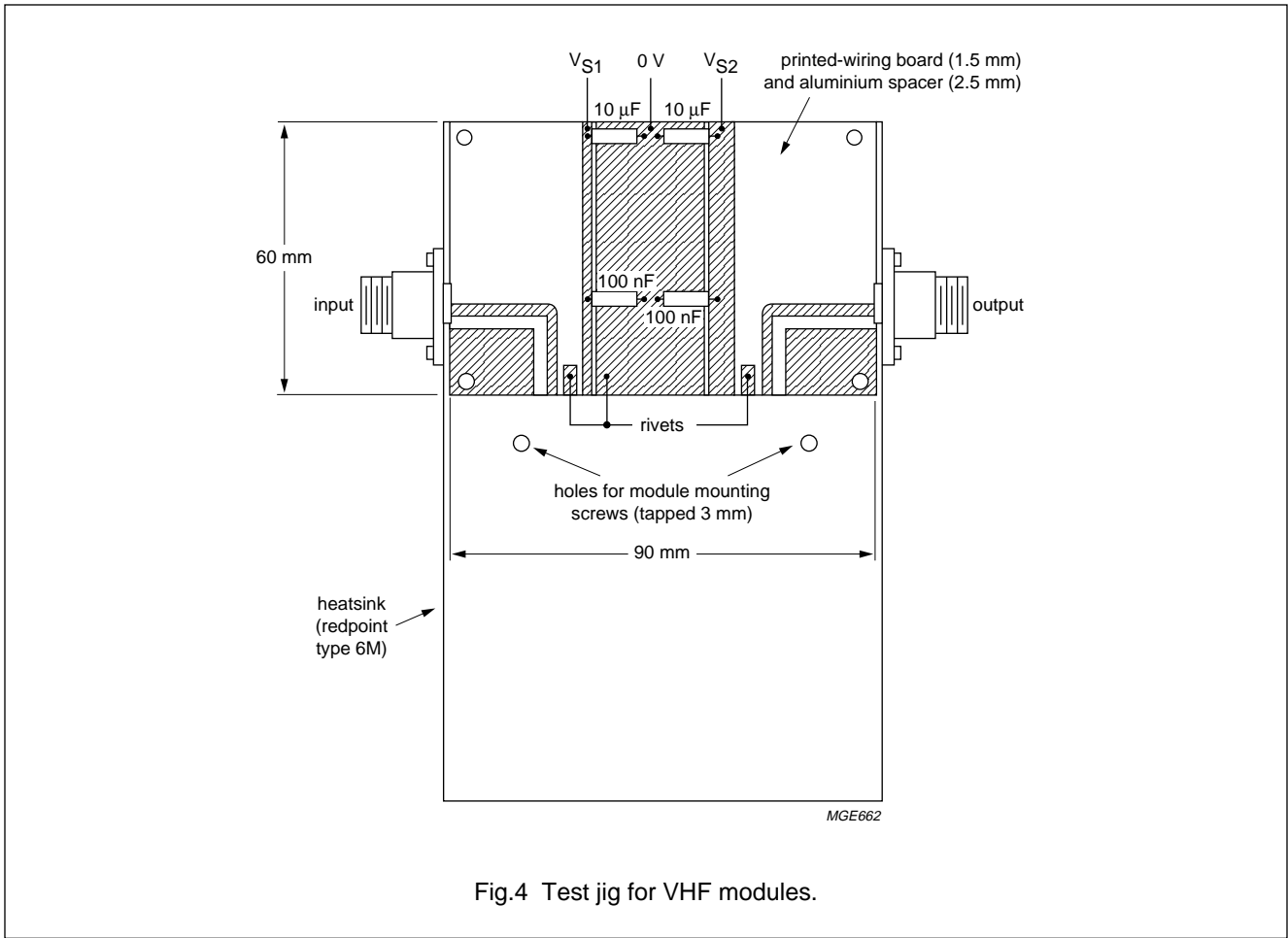

VHF power amplifier module

BGY43

PACKAGE OUTLINE

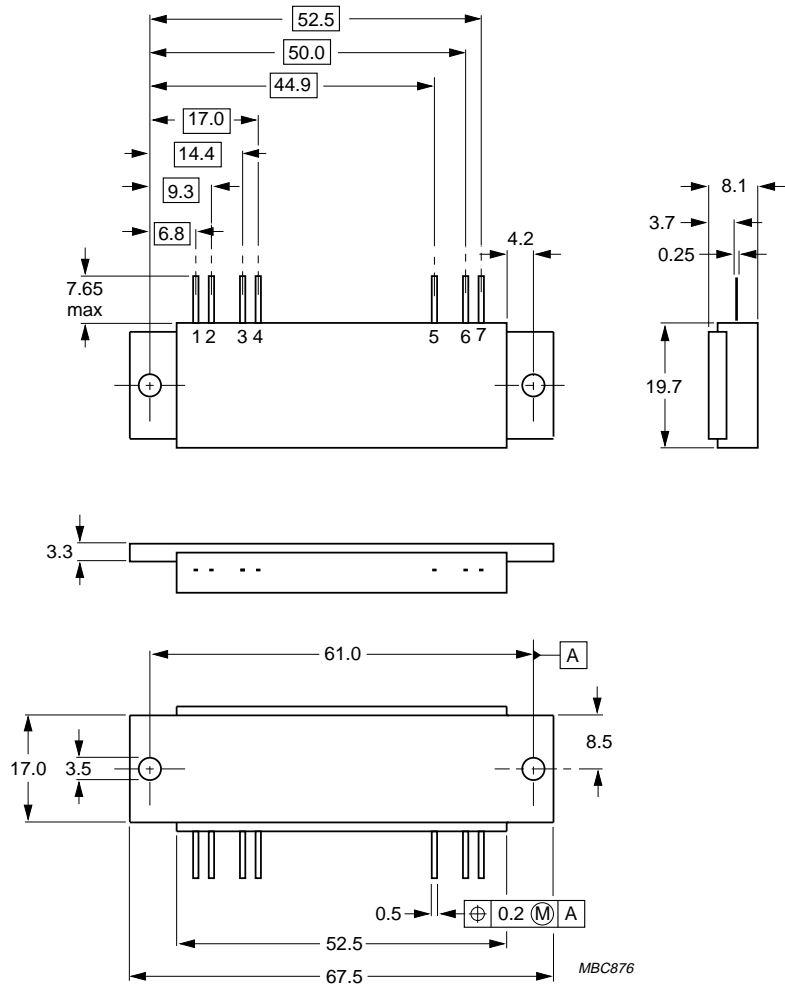

Dimensions in mm.

Fig.6 SOT132B.

VHF power amplifier module

BGY43

DEFINITIONS

Data sheet status	
Objective specification	This data sheet contains target or goal specifications for product development.
Preliminary specification	This data sheet contains preliminary data; supplementary data may be published later.
Product specification	This data sheet contains final product specifications.
Short-form specification	The data in this specification is extracted from a full data sheet with the same type number and title. For detailed information see the relevant data sheet or data handbook.
Limiting values	
Limiting values given are in accordance with the Absolute Maximum Rating System (IEC 134). Stress above one or more of the limiting values may cause permanent damage to the device. These are stress ratings only and operation of the device at these or at any other conditions above those given in the Characteristics sections of the specification is not implied. Exposure to limiting values for extended periods may affect device reliability.	
Application information	
Where application information is given, it is advisory and does not form part of the specification.	

LIFE SUPPORT APPLICATIONS

These products are not designed for use in life support appliances, devices, or systems where malfunction of these products can reasonably be expected to result in personal injury. Philips customers using or selling these products for use in such applications do so at their own risk and agree to fully indemnify Philips for any damages resulting from such improper use or sale.