

DESCRIPTION

The MGF7002 is a monolithic microwave integrated circuit for use in UHF-band low noise amplifiers.

FEATURES

- $G_p = 17$ dB (TYP.) @ $f = 0.9 \sim 1.6$ GHz
- $NF = 2.5$ dB (TYP.) @ $f = 0.9 \sim 1.6$ GHz

APPLICATION

UHF-band Amplifiers

QUALITY GRADE

- GG

OUTLINE DRAWING Unit: millimeters (inches)

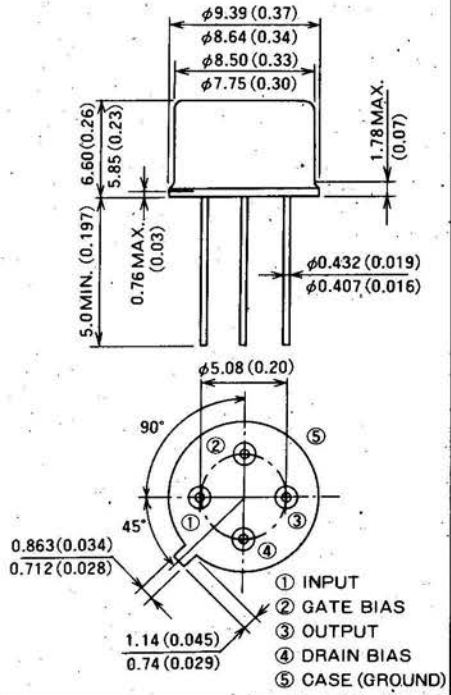

ABSOLUTE MAXIMUM RATINGS ($T_a = 25^\circ\text{C}$)

Symbol	Parameter	Rating	Unit
V_{DD}	Drain operating voltage	10	V
V_{GG}	Gate operating voltage	-6	V
V_{IT}	Input terminal voltage	± 10	V
V_{OT}	Output terminal voltage	± 10	V
I_D	Drain operating current	100	mA
P_T	Total power dissipation	800	mW
T_{ch}	Channel temperature	150	$^\circ\text{C}$
T_{stg}	Storage temperature	-55 ~ +150	$^\circ\text{C}$

ELECTRICAL CHARACTERISTICS ($T_a = 25^\circ\text{C}$)

Symbol	Parameter	Conditions	Limits			Unit
			Min	Typ	Max	
I_D	Drain operating current	$V_{DD} = 7\text{V}, V_{GG} = 0\text{V}$	40	70	100	mA
$V_{GS(off)}$	Gate cut-off voltage	$V_{DD} = 7\text{V}, I_D = 0.1\text{mA}$	-0.5		-4	V
G_p	Power gain	$V_{DD} = 7\text{V}$ $I_D = 40\text{mA}$ $Z_G = 50\ \Omega$ $Z_L = 50\ \Omega$ $f = 0.9 \sim 1.6\text{GHz}$	15	17		dB
NF	Noise figure			2.5	3.5	dB
ρ_{in}	Input VSWR			2.0	3.0	—
ρ_{out}	Output VSWR			2.0	3.0	—
P_{1dB}	Output power at 1 dB gain compression				10	

EQUIVALENT CIRCUIT

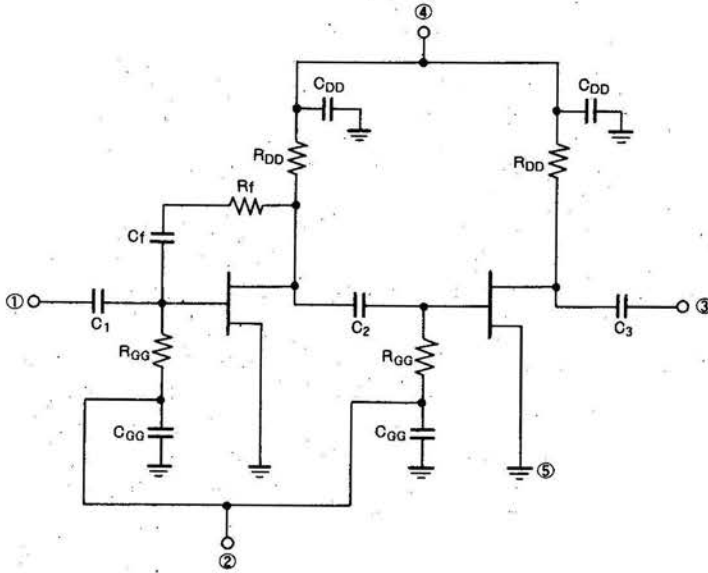

PRECAUTION

It is recommended to connect DC block capacitors to input and output terminal (① and ③) in order to prevent the failure due to surge.

TYPICAL CHARACTERISTICS (Ta = 25°C)

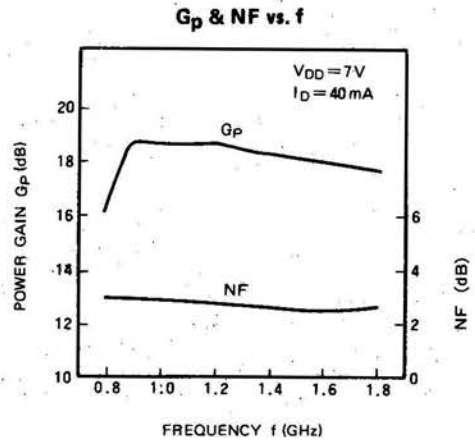
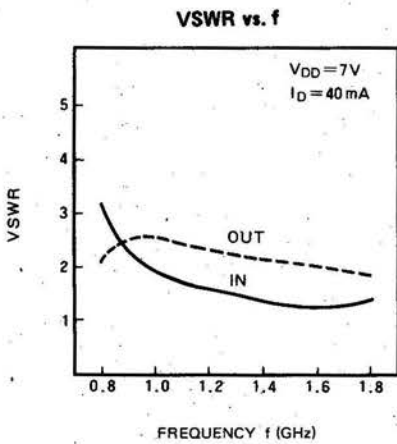

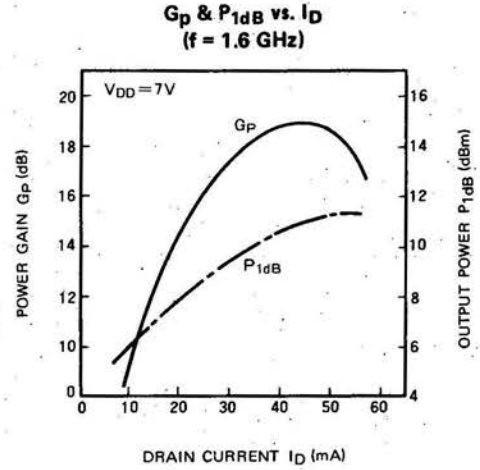
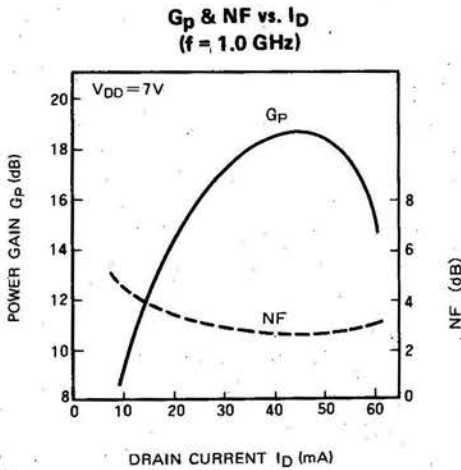
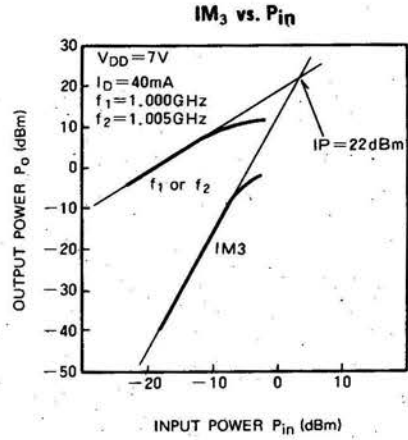
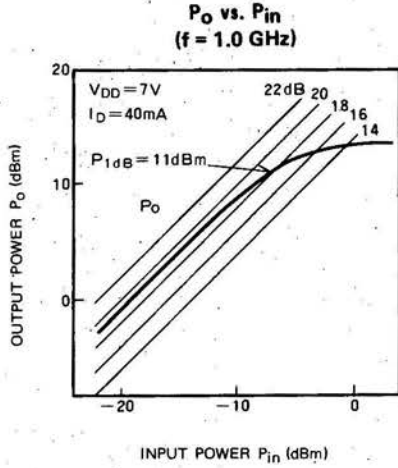

GaAs MONOLITHIC MICROWAVE IC

**AN EXAMPLE OF APPLICATION
 CASCADE AMPLIFIER**

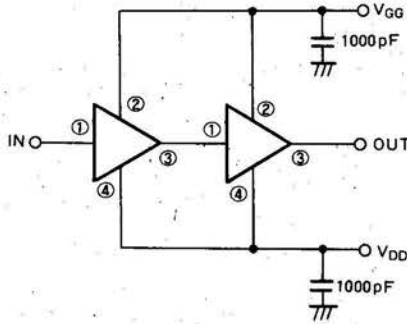

Band width 0.9 ~ 1.6 GHz
 Gain 30 dB Min
 Noise Figure 3.5 dB Max
 Input VSWR 3.0 Max
 Output VSWR 3.0 Max
 Bias conditions $V_{DD} = 7V$
 $I_D = 80 mA$

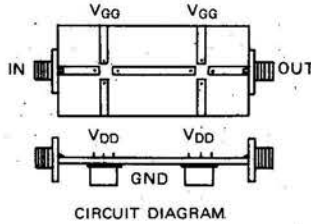

Circuit board Teflon-fiberglass
 (25.4 x 50.8 x 0.8 mm)
 Connector SMA
 Transmission line 50Ω microstrip line
 (Line width 2.2 mm)

- ① INPUT
- ② GATE BIAS
- ③ OUTPUT
- ④ DRAIN BIAS
- ⑤ CASE (GROUND)

TYPICAL CHARACTERISTICS ($T_a = 25^\circ C$)

VSWR vs. f

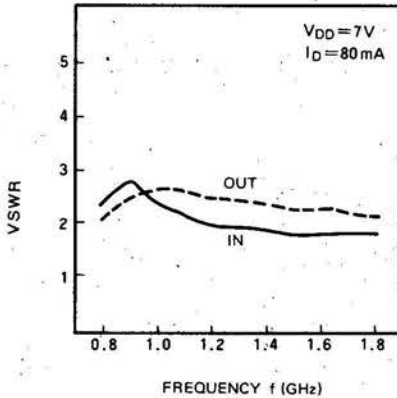

GAIN & NF vs. f

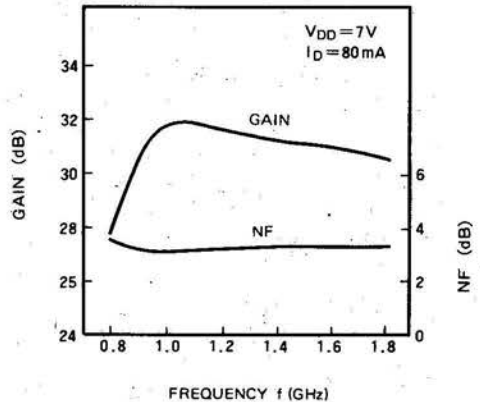

HANDLING PRECAUTIONS

1. Check of Electrical Characteristics

(1) Measurement of DC Characteristics by Curve Tracer

Many curve tracers, if not properly grounded, exhibit a high leakage current from the high-voltage transformer, which can be a prime cause of failure or degradation of the MMIC. Measurement of the DC characteristics using a curve tracer is therefore not recommended. However, when tests using a curve tracer are required, first of all, check that the curve tracer is grounded to earth.

(2) Measurement of RF Characteristics

Before measurement, check that the measuring instruments are grounded to earth. Many instruments to measure RF characteristics such as RF power meters, network analyzers and so on, if not properly grounded to earth, sometimes allow a high AC leakage of up to 20 or more volts, which can be a cause of failure or degradation of the MMIC.

2. Installation of GaAs MMIC

When GaAs MMIC is soldered on a microstrip circuit, the following should be attended to,

(1) Properly ground the soldering iron to earth.

Leakage current from the soldering iron could cause failure or degradation of the MMIC.

(2) Solder the MMIC as promptly as possible at a low temperature. For a criterion, soldering in less than 8 seconds at a temperature of less than 250°C is recommended for each soldering process.

3. Bias Procedure and Conditions

When a GaAs MMIC is biased, the following procedure is recommended.

(1) Slowly adjust the gate to source voltage, V_{GS} , to about -1V.

(2) Gradually increase the drain to source voltage, V_{DS} , from zero to the desired value.

(3) Adjust the drain current, I_D , to the desired value by controlling the gate to source voltage, V_{GS} .

When bias is released, the reverse procedure is recommended.

Be careful that the MMIC is not operated under conditions exceeding the absolute maximum ratings.

4. Guaranteed Characteristics

All the graphic characteristics illustrated in this catalog are typical examples. The characteristics of individual devices as specified in the tables of absolute maximum ratings and electrical characteristics are guaranteed under the specified conditions.