

Dielectric Resonators

SpecWave coaxial ceramic dielectric resonators provide an effective frequency range of 300 MHz to 3 GHz. We offer five standard sizes to allow you flexibility in determining a resonator with optimum frequency Q factor. Our 6 mm resonator provides a combination of frequency Q factor and mechanical size that makes it appropriate for most applications. By contrast, our 12 mm resonator provides the highest Q factor and largest mechanical size.

For applications where available real estate is of concern, we offer three smaller SpecWave packages. Our 2, 3 and 4 mm resonators allow designers to prioritize their requirements for performance and size.

The dimensions and configurations shown on page 5 reference our standard square configurations. In reviewing these packages, it is important to consider that the resonator length is frequency dependent. Silver metalization is applied to form either a quarter wave or half wave resonator. We encourage you to consult our engineering staff for assistance in determining the best size for your application.

Length (L) Calculation

K20

Quarter wave: $L = \frac{.644 (16.38)}{f_o \text{ (GHz)}}$ Half wave: $L = \frac{1.288 (32.75)}{f_o \text{ (GHz)}}$

K35

Quarter wave: $L = \frac{.492 (12.51)}{f_o \text{ (GHz)}}$ Half wave: $L = \frac{.983 (25.00)}{f_o \text{ (GHz)}}$

K88

Quarter wave: $L = \frac{.315 (8.01)}{f_o \text{ (GHz)}}$ Half wave: $L = \frac{.629 (16.00)}{f_o \text{ (GHz)}}$

Dimensions in inches (mm) Fo = Resonant Frequency

Ordering information

The part number shown represents a ceramic resonator with a 6 mm cross-section, a dielectric constant of K 88, a resonant frequency of 445 MHz, and a frequency tolerance of 0.5%. The wavelength type is 1/4 wave. The resonator's plating type is thick film silver and it uses a mounting tab.

Example: **CRF3-0445 A-QST**

| CR | F | 3 | - | 0445 | A | - | Q | S | T |
|-------------------------------------|---|--|---------------------------------------|--|--|--|--|---|---|
| Series Ceramic Resonators | Resonator * Cross-Section B = 2 mm C = 3 mm D = 4 mm F = 6 mm L = 12 mm | Dielectric Constant 1 = K 20 2 = K 35 3 = K 88 | Resonant Frequency fo (MHz) | Frequency Tolerance A = 0.5% B = 1.0% | Wavelength Type Q = 1/4 wave H = 1/2 wave | Plating Type S = Thick Film Silver | Mounting Type T = Mounting Tab Blank = No Tab | | |

* Standard sizes. Consult factory for a custom resonator designed to meet **your** requirements.

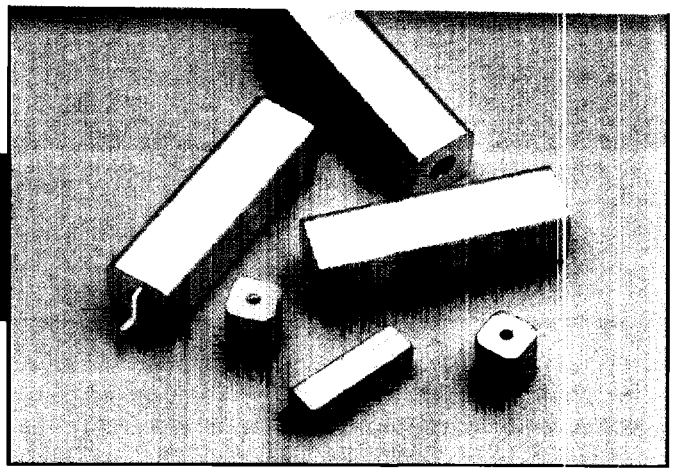

Component Q Quarter Wave

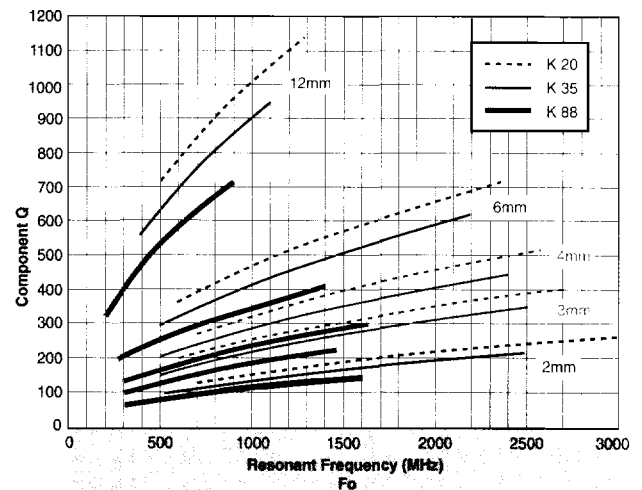

Dielectric Resonators

Dimensions and Configurations

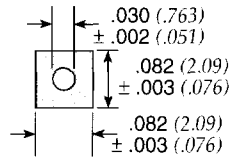
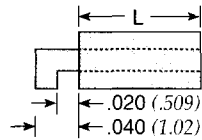

2 mm

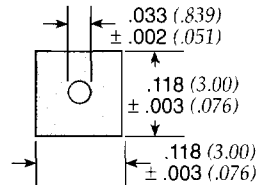
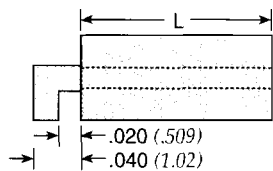

3 mm

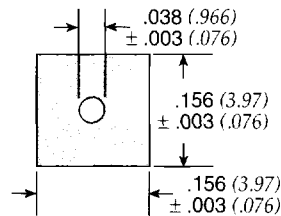
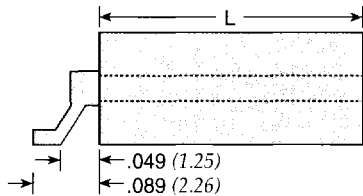

4 mm

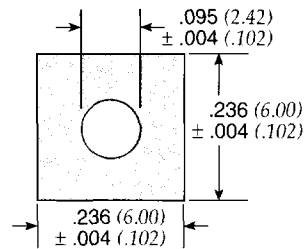
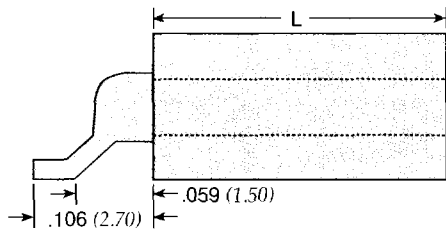

6 mm

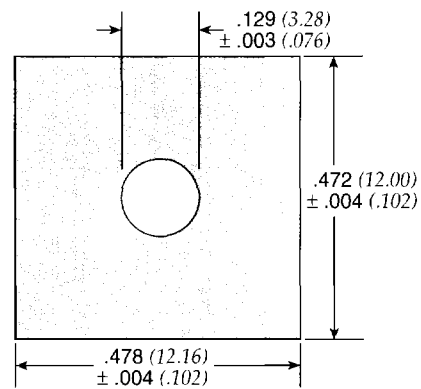
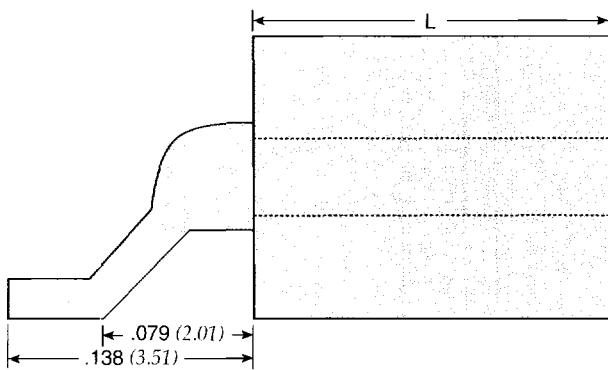

12 mm

Dimensions in inches (mm)