



TRIMMER POTENTIOMETER



4-Turns Cermet Trimmer Potentiometer POT1102 Series

Sealed, 4-turns construction enables precise wiper setting

FEATURES

1. Cermet with 4-turns construction in round style.
2. Unique planetary drive enables precise wiper setting.
3. Clutch mechanism prevents excessive wiper rotation.
4. Compatible with ultrasonic cleaning
(See pages 43 to 44 for details).

APPLICATIONS

Measuring instruments, Facsimile machines, CPUs, PPCs, Printers, Industrial machines

PART NUMBERING

(Please specify the part number when ordering.)

(Ex.)

POT	1102	H	-	1	-	103
-----	------	---	---	---	---	-----

- ① Model
- ② Model number
- ③ Terminal style
- ④ Options 1 : Standard
- ⑤ Resistance code

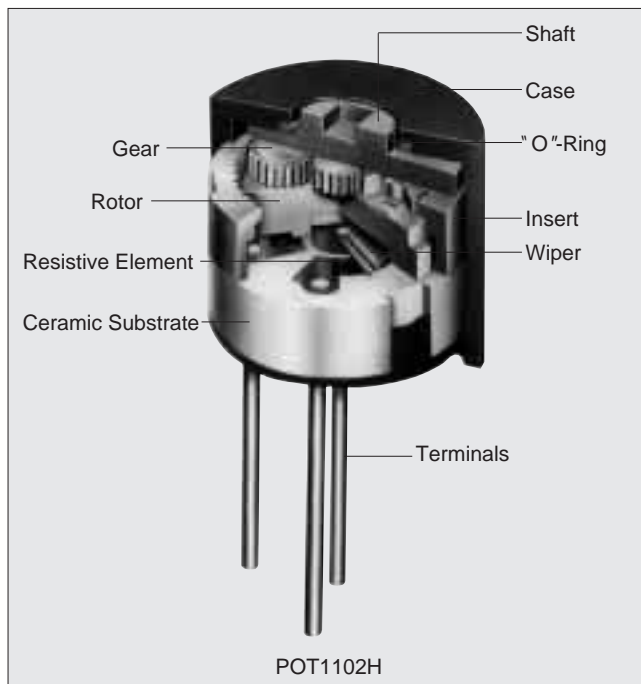

RATINGS

Standard Total Resistance Range	10Ω to 2MΩ
Total Resistance Tolerance	±10% of standard total resistance value
Power Rating	70°C – 0.5W 125°C – 0W
Max. Working Voltage	300Vdc
Max. Wiper Current	100mA max.
Operating Temperature Range	-55°C to +125°C
Effective Number of Turns	4±0.5 turns.
Residual Resistance	2Ω max.
Contact Resistance Variation	3% or 3Ω max. Whichever is greater
Dielectric Strength	600Vac
Insulation Resistance	1000MΩ min. (500Vdc)
Torque	14.7mNm (150gf·cm) max.

OTHERS

- See pages 43 to 44 for Notice
- See pages 46 to 47 for test methods

ENVIRONMENTAL CHARACTERISTICS

Temperature Coefficient of Resistance	±100ppm/°C
Temperature Cycle	ΔTR ±2% ΔV.S. S. ±1%
Humidity Exposure	ΔTR ±2% IR 100MΩ min.
Vibration (20G)	ΔTR ±1% ΔV.S. S. ±1%
Shock (100G)	ΔTR ±1% ΔV.S. S. ±1%
Load Life	ΔTR ±3% ΔV.S. S. ±2%
Low Temperature Exposure	ΔTR ±3% ΔV.S. S. ±1.5%
High Temperature Exposure	ΔTR ±3% ΔV.S. S. ±1.5%
Rotational Life (200 cycles)	No intermittence on resistance change

ΔTR : Total Resistance Change
 ΔV.S.S. : Voltage Setting Stability
 IR : Insulation Resistance

MINIMUM QUANTITY (order in sets only)
 50 pcs./bag

■PART NUMBER TABLE

Standard Total Resistance Values	Model Number			
	Top Adjustment (H)	Top Adjustment (P)	Side Adjustment (T)	Side Adjustment (S)
10Ω	POT1102H-1-100	POT1102P-1-100	POT1102T-1-100	POT1102S-1-100
20Ω	POT1102H-1-200	POT1102P-1-200	POT1102T-1-200	POT1102S-1-200
50Ω	POT1102H-1-500	POT1102P-1-500	POT1102T-1-500	POT1102S-1-500
100Ω	POT1102H-1-101	POT1102P-1-101	POT1102T-1-101	POT1102S-1-101
200Ω	POT1102H-1-201	POT1102P-1-201	POT1102T-1-201	POT1102S-1-201
500Ω	POT1102H-1-501	POT1102P-1-501	POT1102T-1-501	POT1102S-1-501
1kΩ	POT1102H-1-102	POT1102P-1-102	POT1102T-1-102	POT1102S-1-102
2kΩ	POT1102H-1-202	POT1102P-1-202	POT1102T-1-202	POT1102S-1-202
5kΩ	POT1102H-1-502	POT1102P-1-502	POT1102T-1-502	POT1102S-1-502
10kΩ	POT1102H-1-103	POT1102P-1-103	POT1102T-1-103	POT1102S-1-103
20kΩ	POT1102H-1-203	POT1102P-1-203	POT1102T-1-203	POT1102S-1-203
50kΩ	POT1102H-1-503	POT1102P-1-503	POT1102T-1-503	POT1102S-1-503
100kΩ	POT1102H-1-104	POT1102P-1-104	POT1102T-1-104	POT1102S-1-104
200kΩ	POT1102H-1-204	POT1102P-1-204	POT1102T-1-204	POT1102S-1-204
500kΩ	POT1102H-1-504	POT1102P-1-504	POT1102T-1-504	POT1102S-1-504
1MΩ	POT1102H-1-105	POT1102P-1-105	POT1102T-1-105	POT1102S-1-105
2MΩ	POT1102H-1-205	POT1102P-1-205	POT1102T-1-205	POT1102S-1-205

■OUTLINE DIMENSIONS

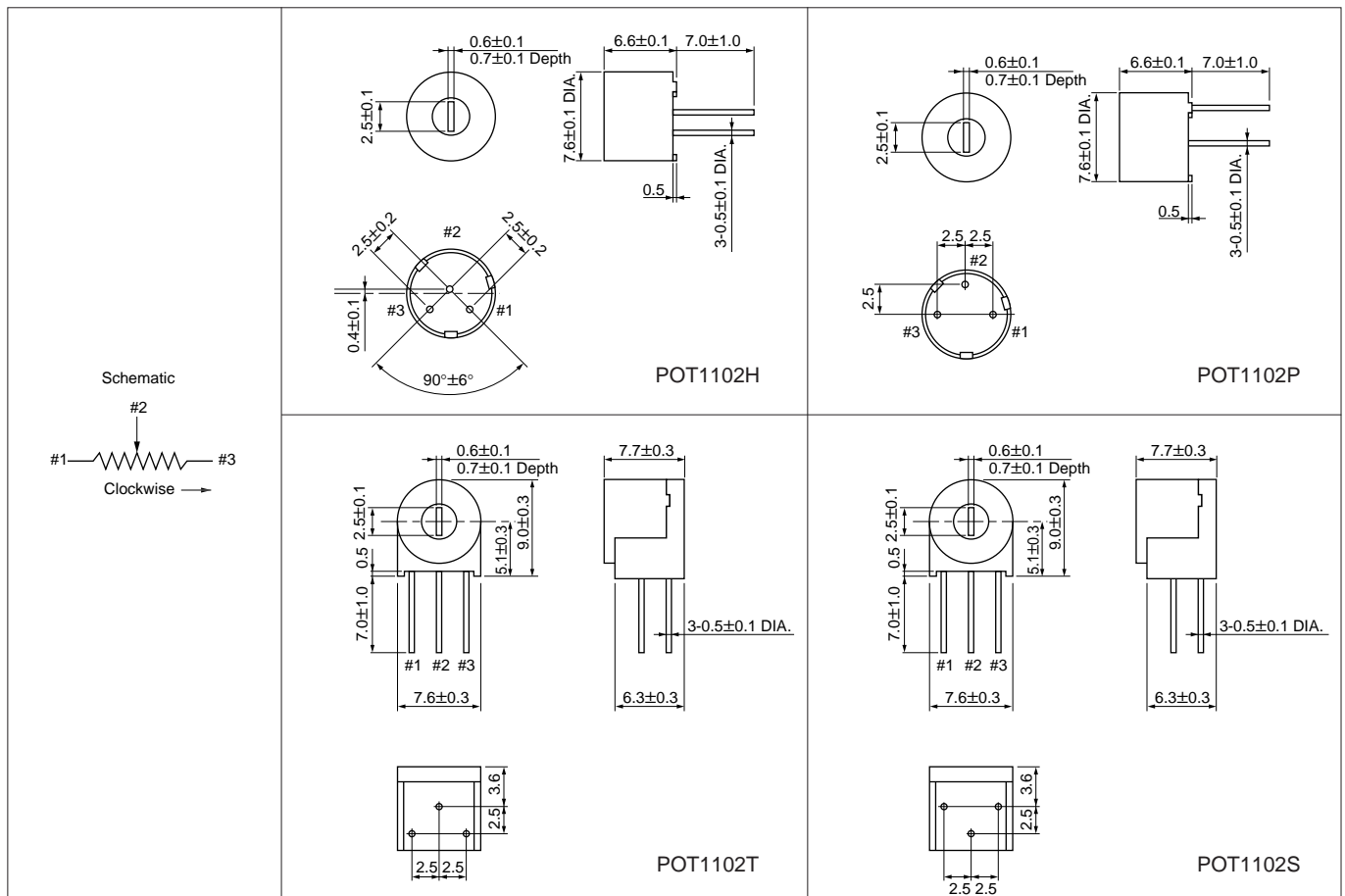

[in mm
Standard tolerance : ±0.3]