

# Ferrite Chip Beads

For power line

## ACC (STD) series

Type:	HFxxACC2012	[0805 inch]*
	HFxxACC3216	[1206 inch]
	HFxxACC3225	[1210 inch]
	HFxxACC4532	[1812 inch]
	HFxxACC5750	[2220 inch]
	HFxxACC6350	

\* Dimensions Code JIS[EIA]

Issue date: December 2010

- All specifications are subject to change without notice.
- Conformity to RoHS Directive: This means that, in conformity with EU Directive 2002/95/EC, lead, cadmium, mercury, hexavalent chromium, and specific bromine-based flame retardants, PBB and PBDE, have not been used, except for exempted applications.

# Chip Beads(SMD) For Power Line

Conformity to RoHS Directive

## HF70ACC, HF50ACC, HF30ACC Series

### FEATURES

- With 4 types rated at 1.5A and 3 types rated at 3A, and with a range of frequency characteristics available for each type, the ACC series facilitates selection of the most appropriate part for any given application.
- Effective EMC suppression over a broad band can be achieved simply by inserting this product into the DC power line on the circuit board.
- Available reflow soldering.
- It is a product conforming to RoHS directive.

### PRODUCT IDENTIFICATION

HF70 ACC 201209 - T  
(1) (2) (3) (4)

- (1) Material name  
(2) Series name  
(3) Dimension code  
(4) Packaging style  
T:  $\varnothing$ 180mm reel taping  
TL:  $\varnothing$ 330mm reel taping

### TEMPERATURE RANGES

Operating	-40 to +125°C
Storage	-40 to +125°C

### PACKAGING STYLE AND QUANTITIES

Packaging style	Type	Quantity
Taping	201209	2000 pieces/reel
	321611	2000 pieces/reel
	322513	2000 pieces/reel
	453215	1000 pieces/reel
	575018	500 pieces/reel
	575032	500 pieces/reel
	635050	300 pieces/reel

### HANDLING AND PRECAUTIONS

- Before soldering, be sure to preheat components. The preheating temperature should be set so that the temperature difference between the solder temperature and product temperature does not exceed 150°C.
- After mounting components onto the printed circuit board, do not apply stress through board bending or mishandling.
- Do not expose the inductors to stray magnetic fields.
- Avoid static electricity discharge during handling.
- When hand soldering, apply the soldering iron to the printed circuit board only. Temperature of the iron tip should not exceed 350°C. Soldering time should not exceed 3 seconds.

- Conformity to RoHS Directive: This means that, in conformity with EU Directive 2002/95/EC, lead, cadmium, mercury, hexavalent chromium, and specific bromine-based flame retardants, PBB and PBDE, have not been used, except for exempted applications.

- Please contact our Sales office when your application are considered the following:  
The device's failure or malfunction may directly endanger human life (e.g. application for automobile/aircraft/medical/nuclear power devices, etc.)

- All specifications are subject to change without notice.

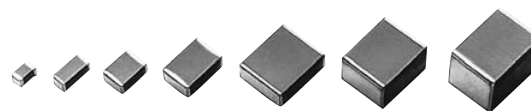

### SHAPES AND DIMENSIONS/CIRCUIT DIAGRAM

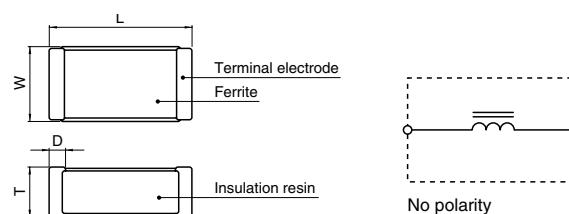

Type	L	W	T	D
201209	2.0±0.2	1.25±0.2	0.9±0.2	0.3±0.2
321611	3.2±0.2	1.6±0.2	1.1±0.2	0.3±0.2
322513	3.2±0.2	2.5±0.2	1.3±0.2	0.3±0.2
453215	4.5±0.25	3.2±0.25	1.5±0.25	0.3±0.2
575018	5.7±0.4	5.0±0.3	1.8±0.3	0.2
575032	5.7±0.4	5.0±0.3	3.2±0.3	0.2
635050	6.4±0.4	5.0±0.3	4.74±0.3	0.2

- Dimension without tolerance is reference value.

### RECOMMENDED PC BOARD PATTERN

#### REFLOW SOLDERING

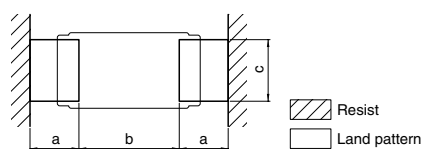

Type	a	b	c
201209	1.0	1.0	1.0
321611	1.1	2.2	1.4
322513	1.1	2.2	2.3
453215	1.5	3.0	3.0
575018	2.0	4.0	5.8
575032	2.0	4.0	5.8
635050	2.0	4.5	5.8

**ELECTRICAL CHARACTERISTICS**

Shape	Part No.	Impedance ( $\Omega$ )[100MHz]	DC resistance ( $\Omega$ )max.	Rated current (A)max.
201209	HF70ACC201209	10 $\pm$ 25%	0.03	1.5
	HF50ACC201209	11 $\pm$ 25%	0.03	1.5
	HF30ACC201209	7 $\pm$ 25%	0.03	1.5
321611	HF70ACC321611	26 $\pm$ 25%	0.04	1.5
	HF50ACC321611	31 $\pm$ 25%	0.04	1.5
	HF30ACC321611	19 $\pm$ 25%	0.04	1.5
322513	HF70ACC322513	52 $\pm$ 25%	0.05	1.5
	HF50ACC322513	60 $\pm$ 25%	0.05	1.5
	HF30ACC322513	31 $\pm$ 25%	0.05	1.5
453215	HF70ACC453215	120 $\pm$ 25%	0.05	1.5
	HF50ACC453215	125 $\pm$ 25%	0.05	1.5
	HF30ACC453215	70 $\pm$ 25%	0.05	1.5
575018	HF70ACC575018	150 $\pm$ 25%	0.04	3.0
	HF50ACC575018	180 $\pm$ 25%	0.04	3.0
	HF30ACC575018	100 $\pm$ 25%	0.04	3.0
575032	HF70ACC575032	300 $\pm$ 25%	0.04	3.0
	HF50ACC575032	400 $\pm$ 25%	0.04	3.0
	HF30ACC575032	270 $\pm$ 25%	0.04	3.0
635050	HF70ACC635050	500 $\pm$ 25%	0.04	3.0
	HF30ACC635050	750 $\pm$ 25%	0.04	3.0

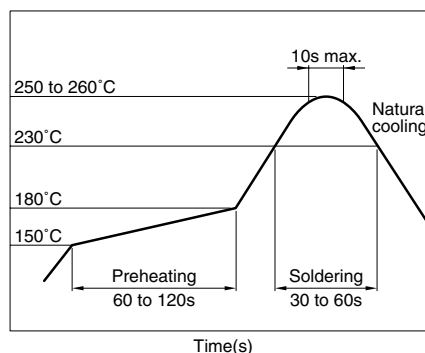
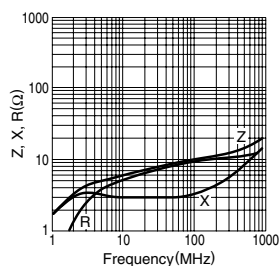
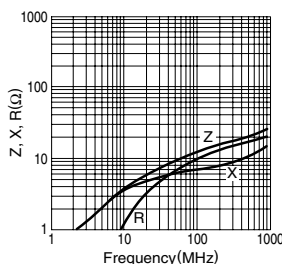
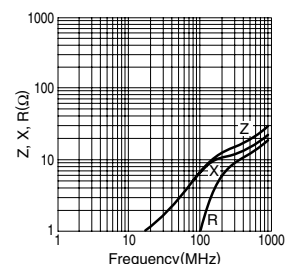
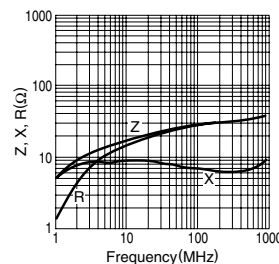
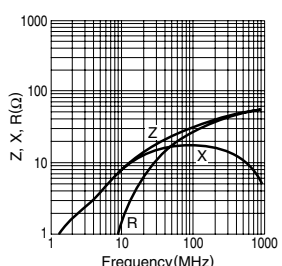
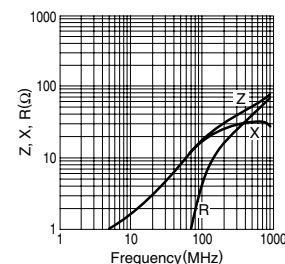
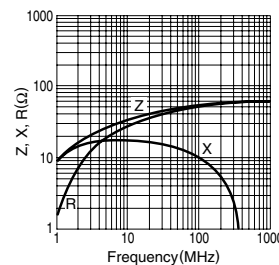
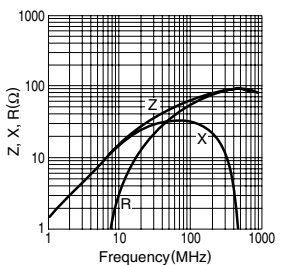
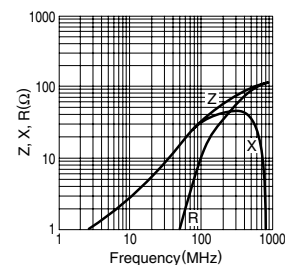
**RECOMMENDED SOLDERING CONDITION  
REFLOW SOLDERING**

**TYPICAL ELECTRICAL CHARACTERISTICS  
Z, X, R vs. FREQUENCY CHARACTERISTICS  
HF70ACC201209**

**HF50ACC201209**

**HF30ACC201209**

**HF70ACC321611**

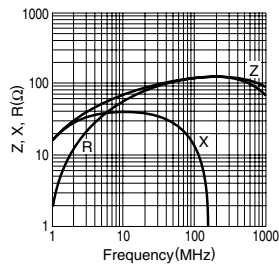
**HF50ACC321611**

**HF30ACC321611**

**HF70ACC322513**

**HF50ACC322513**

**HF30ACC322513**

• TEST EQUIPMENT:RF IMPEDANCE ANALYZER YHP4191A

• All specifications are subject to change without notice.

**TYPICAL ELECTRICAL CHARACTERISTICS**  
**Z, X, R vs. FREQUENCY CHARACTERISTICS**

**HF70ACC453215**



**HF50ACC453215**

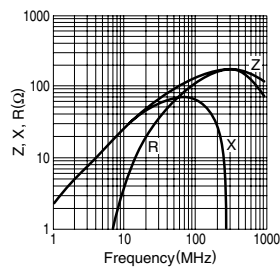

**HF30ACC453215**

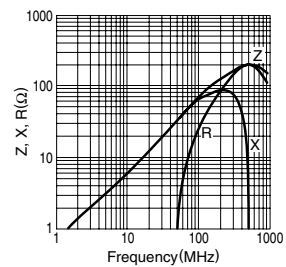

**HF70ACC575018**

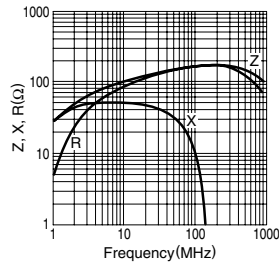

**HF50ACC575018**

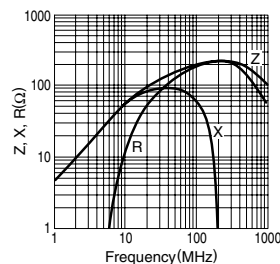

**HF30ACC575018**

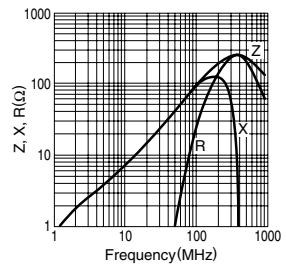

**HF70ACC575032**

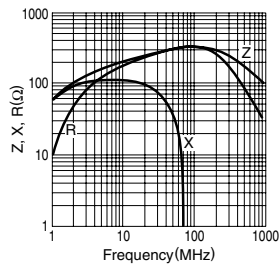

**HF50ACC575032**

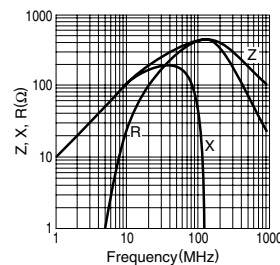

**HF30ACC575032**

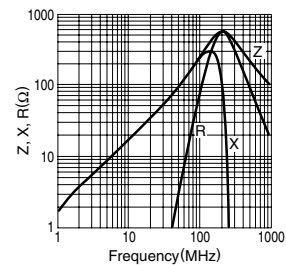

**HF70ACC635050**

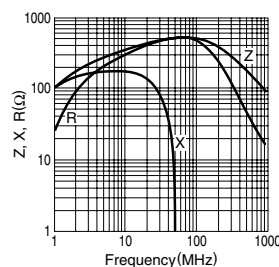

**HF50ACC635050**

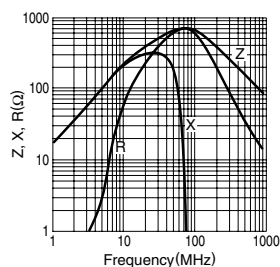

**HF30ACC635050**

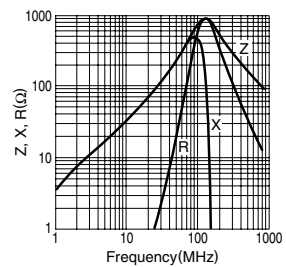

• TEST EQUIPMENT:RF IMPEDANCE ANALYZER YHP4191A

• All specifications are subject to change without notice.

**PACKAGING STYLES**  
**201209 TO 322513 TYPES**  
**REEL DIMENSIONS**

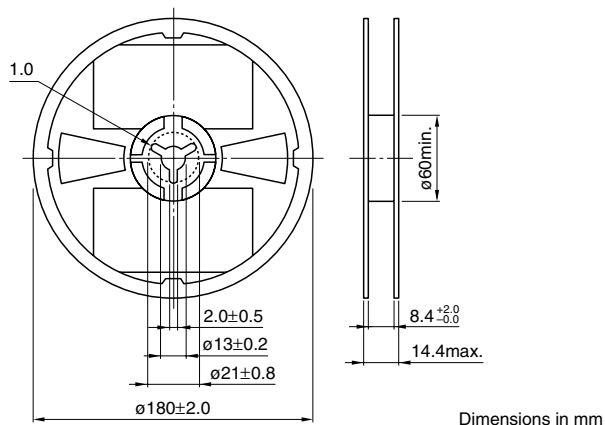

**453215 TO 635050 TYPES**  
**REEL DIMENSIONS**

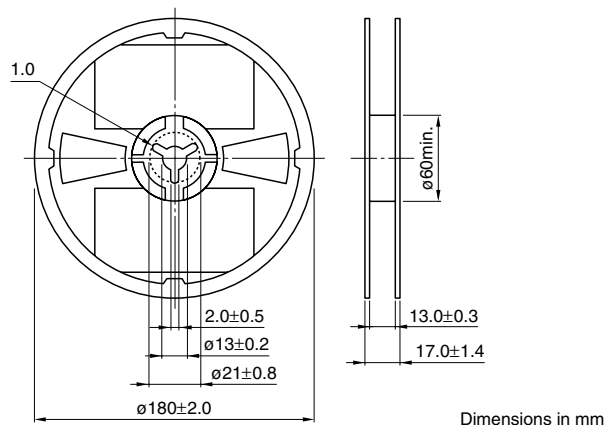

**TAPE DIMENSIONS**

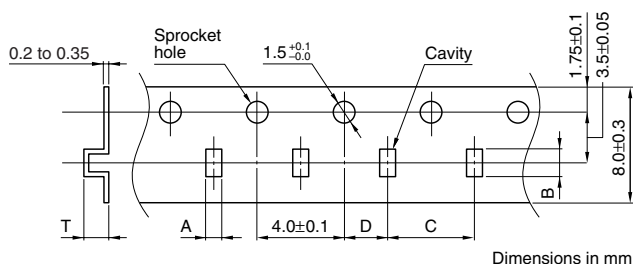

Type	A	B	C	D	T
201209	1.4±0.1	2.25±0.1	4.0±0.1	2.0±0.05	1.25max.
321611	1.75±0.1	3.45±0.1	4.0±0.1	2.0±0.05	1.4max.
322513	2.6±0.1	3.45±0.1	4.0±0.1	2.0±0.05	1.6max.

**TAPE DIMENSIONS**

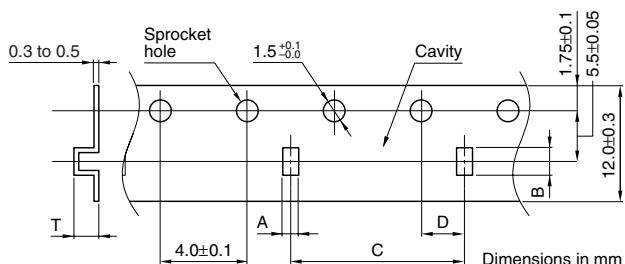

Type	A	B	C	D	T
453215	3.37±0.1	4.75±0.1	8.0±0.1	2.0±0.05	1.8max.
575018	5.4±0.1	6.2±0.1	8.0±0.1	2.0±0.05	2.4max.
575032	5.4±0.1	6.2±0.1	8.0±0.1	2.0±0.05	3.8max.
635050	5.4±0.1	6.85±0.1	8.0±0.1	2.0±0.05	5.1max.

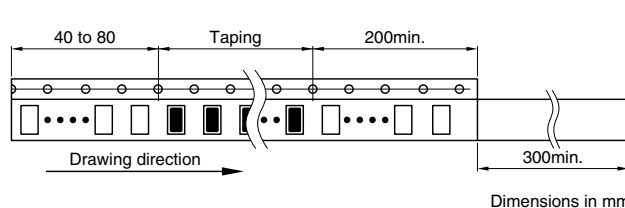
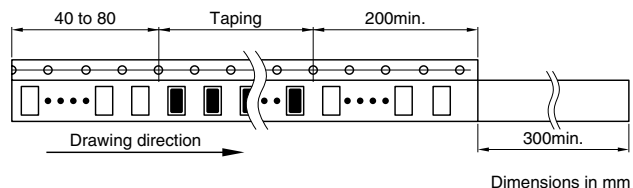

• All specifications are subject to change without notice.