

8764

G

TUNING TOOL (MOLDED)

NOTES:

FILE: AIROUT

1. HANDLE TO BE FREE OF ALL GATE BURRS & FLASH.
2. ALL HEX CORNERS .005 RADIUS.
3. a. MOLD BIT (8765-1) IN PLACE CENTRALLY, AS DEPICTED
b. SURFACE OF EMBEDDED PORTION OF BIT OPTIONAL FOR GOOD MOLDING PRACTICES & MAXIMUM STRENGTH.
4. .015 MAX. FLASH ALLOWED BEYOND .06/.04 DIMENSION.
5. MATERIAL:
ZYTEL 70G33HS1L NC010
6. COLOR: UN5011, MID BLUE.

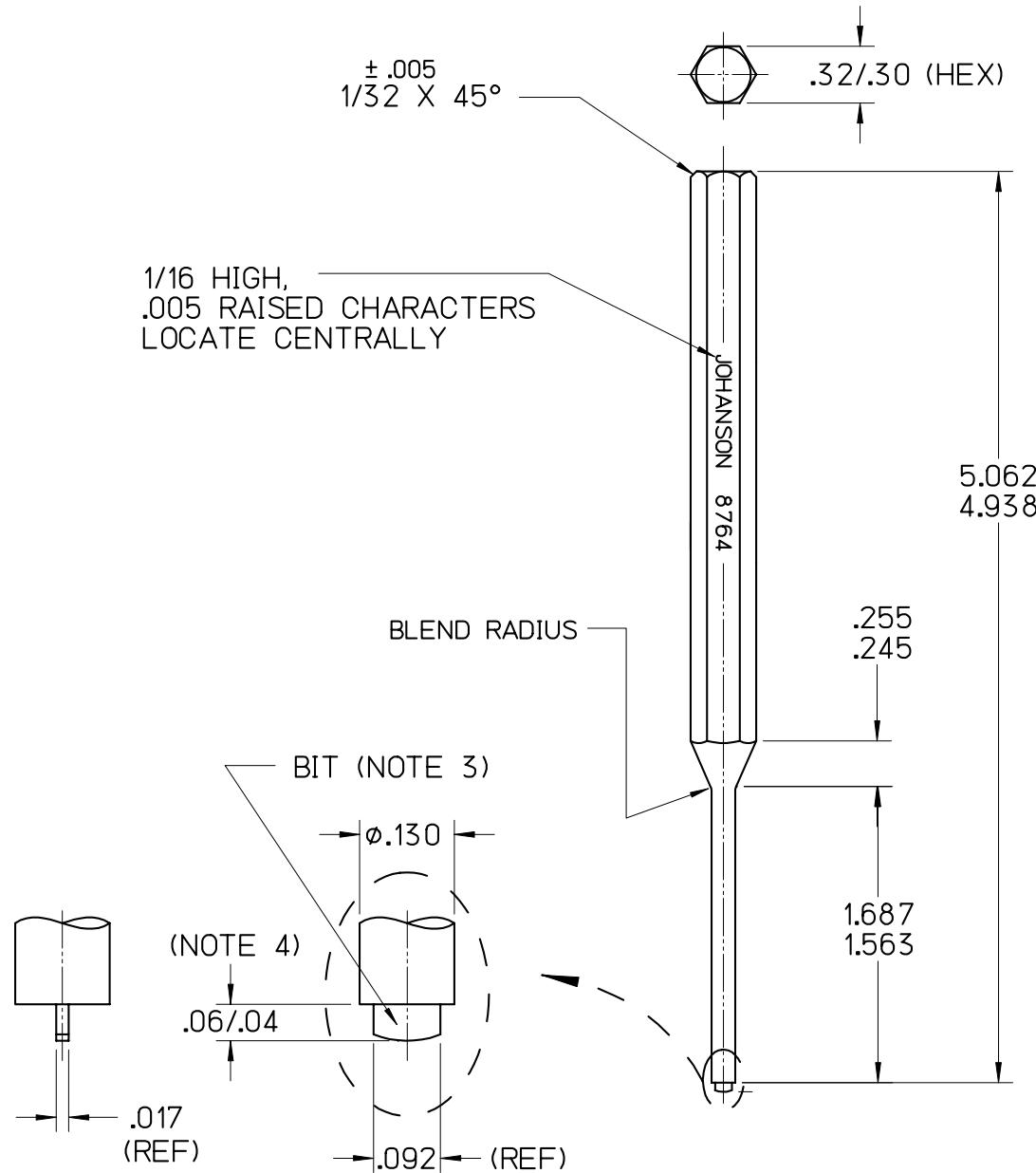

G	7/22/08	RJV	RJV	MAI	000685
LEVEL	DATE	DRN.	CHK.	APP.	ECN

REVISIONS

DRN. MLD	CHK. TAM	APP. JHT	SCALE 1" = 1"
DATE 03/28/00	DATE 04/03/00	DATE 04/03/00	.XX ± .015 .XXX ± .005



JOHANSON MANUFACTURING CORPORATION
 ROCKAWAY VALLEY ROAD, BOONTON, N.J. 07005 (973)334-2676 FAX (973)334-2954
 ELECTRONIC ACCURACY THROUGH MECHANICAL PRECISION