

Tuning Tools

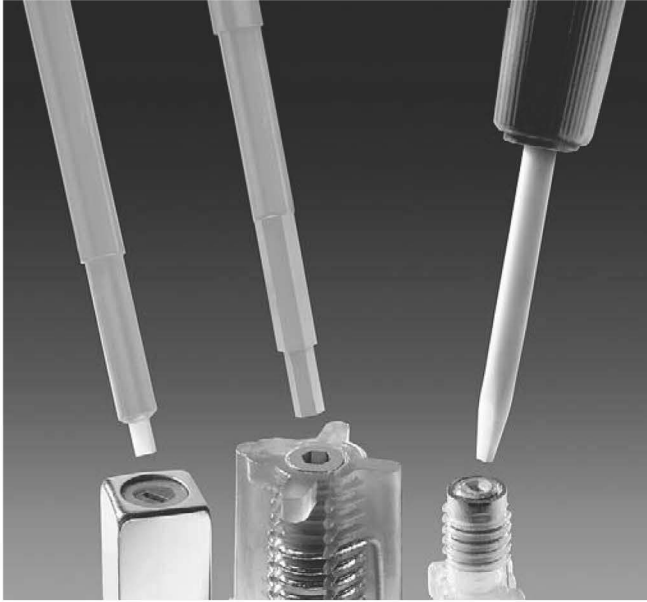

These exclusive tools are ideal for tuning inductors, capacitors and many other variable components.

The **Trituner™** is a unique 3-in-1 tool. Molded of rugged PET thermoplastic material, one end is stepped with a hex tip for 1/4-28 cores and a smaller hex tip for 10-32 cores. Both have a large surface area to prevent fragile cores from stripping or breaking. The other end has a molded-in ceramic straight tip for 6-32 slotted cores. This provides the strength of steel but is totally non-magnetic.

- One tool does the work of three
- Non-magnetic ceramic screwdriver tip for durability

The **Slot Tuner** tool has a non-conductive ceramic shaft with a 0.8 mm × 1.3 mm screwdriver tip. The plastic handle has a convenient grip surface and a rotating end to help you make fine adjustments easily.

- The ideal tool for all Coilcraft “Slot Seven” parts
- Non-magnetic ceramic screwdriver tip for durability

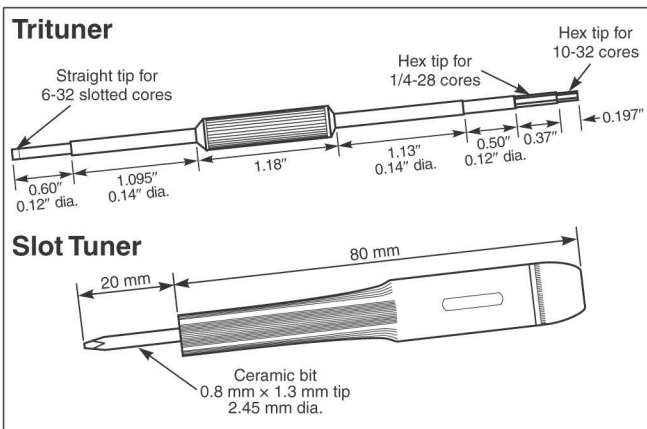

Coilcraft part	Recommended tool
"Unicoil" 5 mm inductors	Trituner
"Unicoil" 7 mm inductors	Trituner
"Unicoil" 10 mm inductors	Trituner
"Slot Seven" 7 mm inductors	Slot Tuner
"Slot Ten" 10 mm inductors	Trituner
148 Series low profile inductors	Trituner