

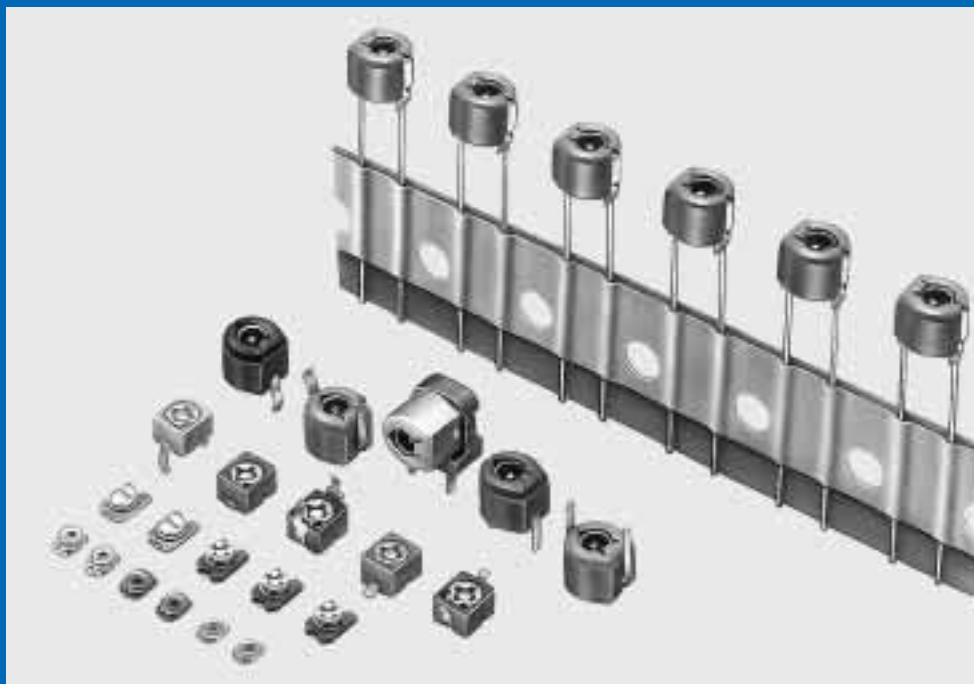

CERAMIC TRIMMER CAPACITOR

CERAMIC TRIMMER CAPACITOR



muRata

*Innovator
in Electronics*

Murata
Manufacturing Co., Ltd.



Cat.No.T13E-4

What kind of trimmer capacitor are you looking for?

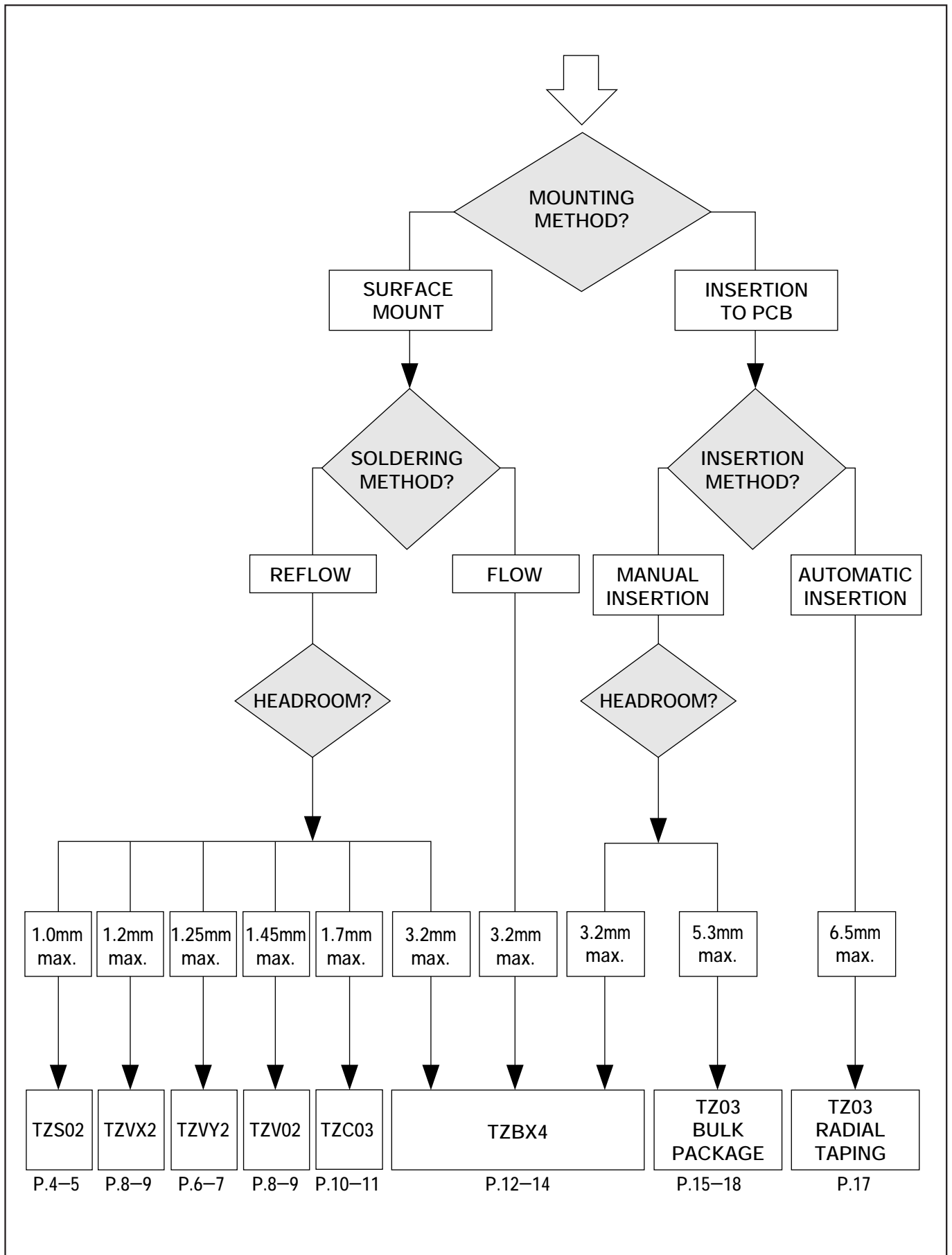
You will find the suitable one from Murata's numerous product line on trimmer capacitor.

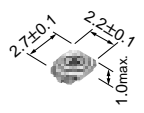
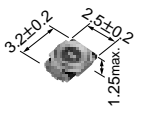
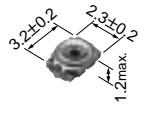
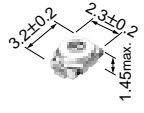
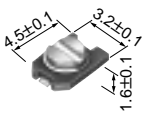

■MURATA TRIMMER CAPACITOR SELECTION GUIDE

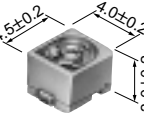
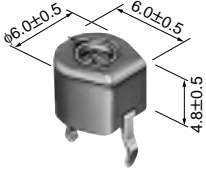
Model Number	Product External Dimensions (mm)	Maximum Capacitance Value (pF)	Volume (mm ³)	Height (mm)	Weight (g)	Automatic Adjustment	Page
TZS02 Series		6 • 10 • 20	6	1.0	0.02	Applicable	4–5
NEW TZVY2 Series		3 • 6 • 10 • 20 • 25 • 45	10	1.25	0.03	Applicable	6–7
TZVX2 Series		2.5 • 3 • 6 • 10 • 20	9	1.2	0.03	Applicable	8–9
TZV02 Series		2.5 • 3 • 6 • 10 • 20	11	1.45	0.04	Applicable	8–9
TZC03 Series	Standard Type (Minus Slot) 	3 • 6 • 10 • 20 • 30	23	1.6	0.06	Applicable	10–11
	Cross Slot Type 			1.7			
TZBX4 Series		3 • 6 • 10 • 20 • 25 • 30 • 40 • 50	54	3.0	0.17	Applicable	12–14
TZ03 Series		2.3 • 5 • 7 • 10 • 11 • 20 • 30 • 45 • 50 • 60 • 90 • 120	180	5.0	0.41	Applicable	15–18

● Taping specifications for chip trimmer capacitors.....P.19

● Notes.....P.20 to 21

■ RECOMMENDED SCREWDRIVER FOR MANUAL ADJUSTMENT

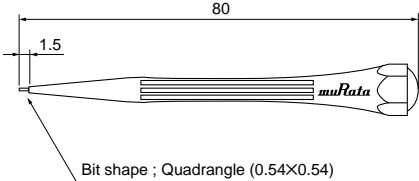
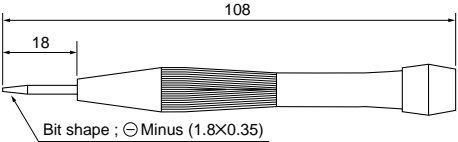
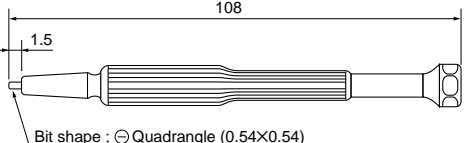
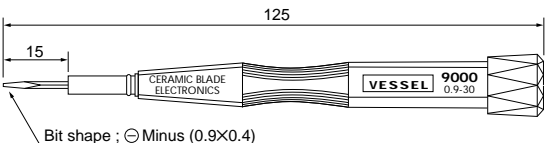
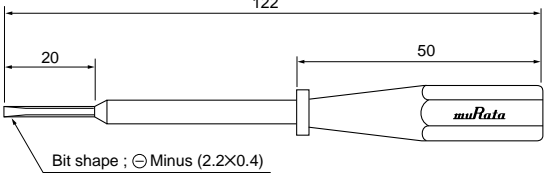
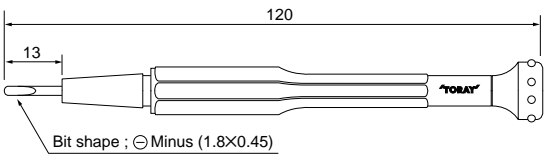
Model Number (Trimmer Capacitors)	Part Number	Screwdriver (in mm)
TZS02	KMT04	 <p>80</p> <p>1.5</p> <p>Bit shape ; Quadrangle (0.54X0.54)</p>
TZVY2	KMTZ16F	<p>FUTABA TOOL MFG.CO.,LTD. DA-89</p>  <p>108</p> <p>18</p> <p>Bit shape ; ⊖ Minus (1.8X0.35)</p>
TZVX2	KMTZ15T	<p>TORAY INDUSTRIES, INC. SA-5406</p>  <p>108</p> <p>1.5</p> <p>Bit shape ; ⊖ Quadrangle (0.54X0.54)</p>
TZV02	KMTZ11V	<p>VESSEL MFG. NO.9000 ⊖09x3.0</p>  <p>125</p> <p>15</p> <p>Bit shape ; ⊖ Minus (0.9X0.4)</p>
TZC03 Standard Type (Minus Slot) TZBX4 TZ03	PPTZ-0022	 <p>122</p> <p>20</p> <p>50</p> <p>Bit shape ; ⊖ Minus (2.2X0.4)</p>
TZC03 Cross Slot Type	KMTZ14T	<p>TORAY INDUSTRIES, INC. SA-1825</p>  <p>120</p> <p>13</p> <p>Bit shape ; ⊖ Minus (1.8X0.45)</p>

Consult a MURATA Factory representative regarding other adjustment tools.

■RECOMMENDED SCREWDRIVER BIT FOR AUTOMATIC ADJUSTMENT

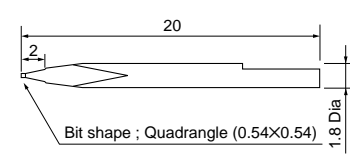
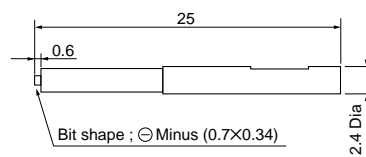
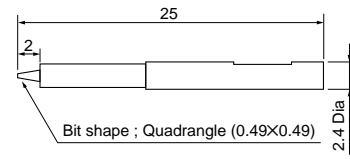
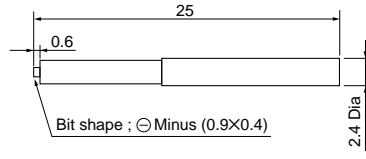
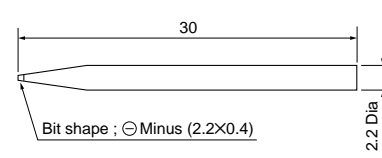
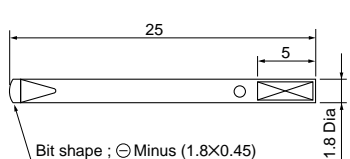
Model Number (Trimmer Capacitors)	Part Number	Screwdriver Bit (in mm)
TZS02	KMTZ39	 <p>20 2 1.8 Dia Bit shape ; Quadrangle (0.54X0.54)</p>
TZVY2	KMTZ40K	 <p>25 0.6 2.4 Dia Bit shape ; ⊖ Minus (0.7X0.34)</p>
TZVX2	KMTZ37K	 <p>25 2 2.4 Dia Bit shape ; Quadrangle (0.49X0.49)</p>
TZV02	KMTZ32K	 <p>25 0.6 2.4 Dia Bit shape ; ⊖ Minus (0.9X0.4)</p>
TZC03 Standard Type (Minus Slot) TZBX4 TZ03	KMTZ35	 <p>30 2.2 Dia Bit shape ; ⊖ Minus (2.2X0.4)</p>
TZCO3 Cross Slot Type	KMTZ36T	<p>TORAY INDUSTRIES,INC. JB-1825</p>  <p>25 5 1.8 Dia Bit shape ; ⊖ Minus (1.8X0.45)</p>

■QUALIFIED STANDARDS

MURATA FACTORY	Qualified Date	Standard	Qualified Number
SABAE MURATA MFG CO.,LTD.	August 14, 1997	ISO9001 and QS9000	A5704



CHIP TRIMMER CAPACITOR



Chip Ceramic Trimmer Capacitor TZX02 Series

Just 1mm Height Chip Trimmer Capacitor with Excellent Heat Resistance and Stable Characteristics

■FEATURES

1. Ultra-small and thin type with external dimensions of 2.2(W)×2.7(L)×0.95(T)mm. (30% less in volume from TZVX2.)
2. Newly designed metal rotor and rugged construction ensure high stability thereby minimizing capacitance drift after adjustment.
3. Unique construction with no plastic material provides superior soldering heat resistance to maintain excellent characteristic performance after reflow soldering.
4. Mountable by automatic placer.
5. Funnel shaped metal case and pierced square hole enable in-process automatic adjustment. Pierced square hole allows high resistance to tuning force.
6. Including the fixed capacitor, built-in capacitor in parallel with trimmer capacitor type is also available. It makes reduction of space and cost of mounting in circuit. Please contact us about the capacitance value of built-in capacitor.

■APPLICATIONS

- Crystal oscillators, Crystal filters
- Pagers
- Cordless telephones
- Camcorders
- Hand-held telephones, Automotive telephones
- Hand radios
- Radar detectors
- Remote keyless entry systems

■PART NUMBERING

(Please specify the part number when ordering.)

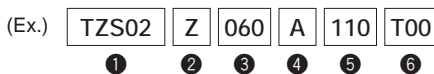

- ① Model Number
- ② Temperature Coefficient Characteristics
- ③ Capacitance Value
- ④ Terminal Style
- ⑤ Other Specification 110:Standard
- ⑥ Packaging Code T00:Taping 3,000pcs./reel (180mm dia.)
T01:Taping 10,000pcs./reel (330mm dia.)
No Code: Bulk Package 500pcs./bag

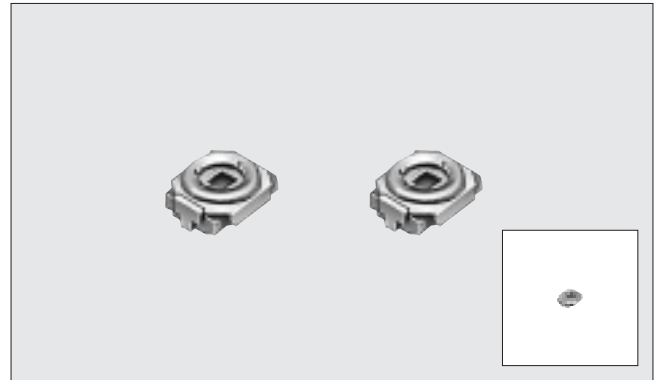

■CONSTRUCTION

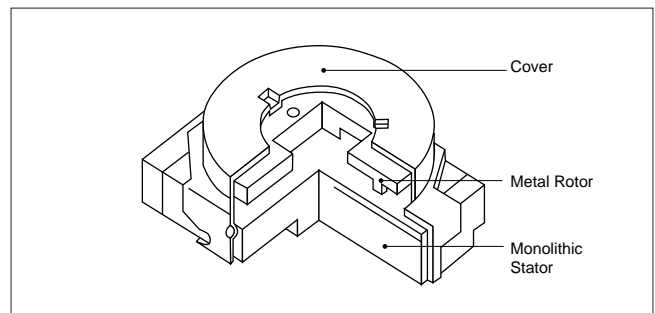

■DIMENSIONS/STANDARD LAND PATTERNS

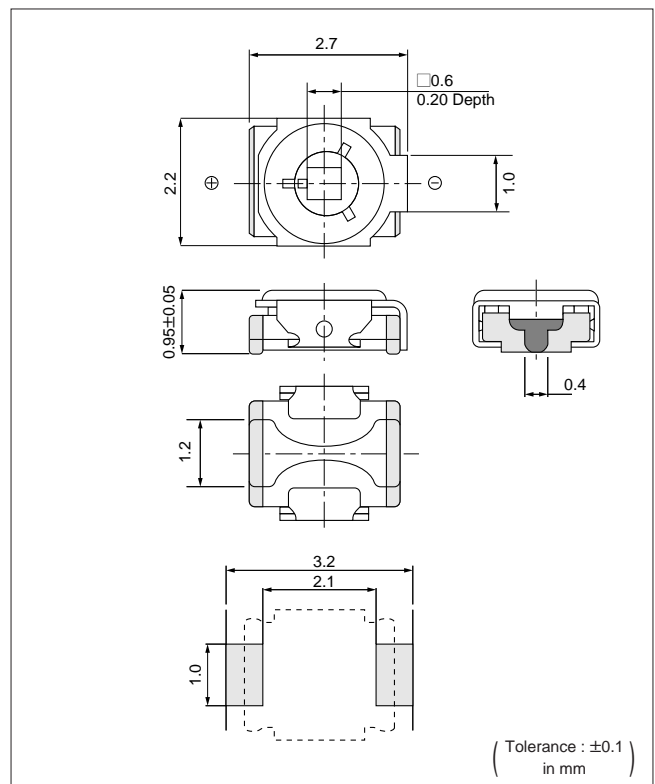

■ RATINGS

Part Number	Capacitance (pF)		Temperature Coefficient (ppm/°C)	Q <1MHz, Cmax.>	Stator Color
	Min. (max.)	Max. ($\pm 10\%$)			
TZS02Z060A110	3.0	6.0	NP0 ± 300 (0 ± 300)	500 min.	Light Green
TZS02Z100A110	3.5	10.0	NP0 ± 300 (0 ± 300)	500 min.	Light Green
TZS02R200A110	7.0	20.0	N750 ± 500 (-750 ± 500)	500 min.	Brown

- Rated Voltage:25Vdc •Withstanding Voltage:55Vdc •Insulation Resistance:10¹⁰MΩmin.
- Driving Torque:0.5 to 5.0 mN·m (Ref.5 to 50g·cm) •Working Temperature Range:-25 to +85°C

■ CHARACTERISTICS

● Temperature Coefficient Characteristics

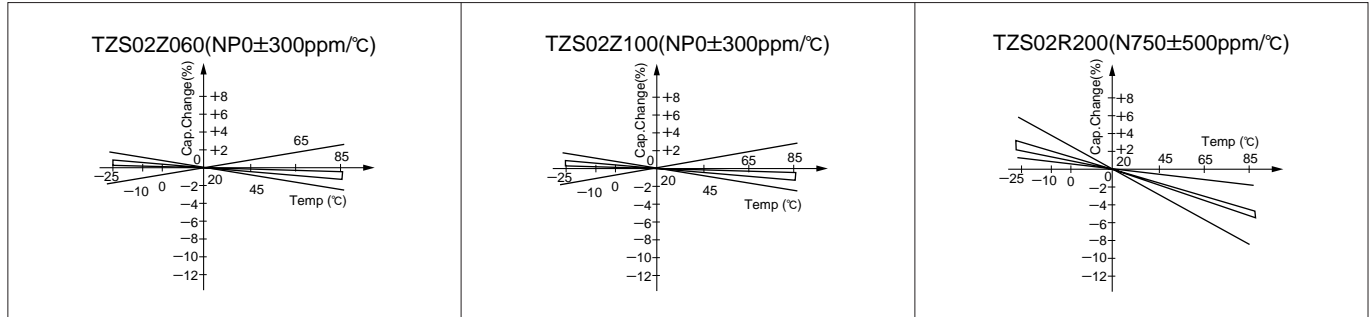

● Q and Capacitance vs. Frequency Characteristics

Characteristics are measured at the maximum rated capacitance value position.

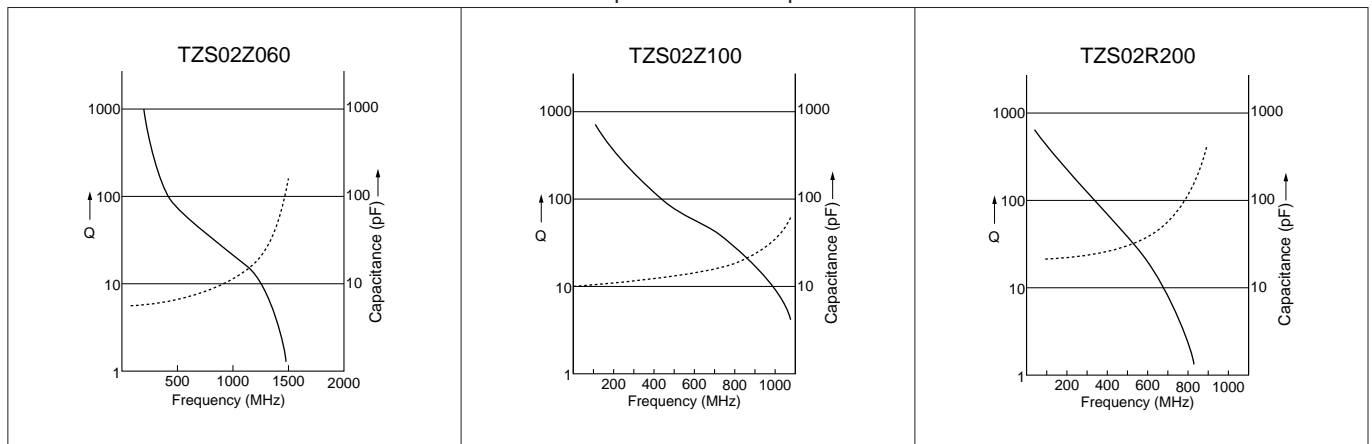

Q : Solid line Capacitance : Dotted line

■ TAPING SPECIFICATIONS / HANDLING PRECAUTIONS / SOLDERING CONDITIONS

- See pages 19 to 21.



CHIP TRIMMER CAPACITOR



Chip Ceramic Trimmer Capacitor TZVY2 Series

Low Cost Chip Trimmer Capacitor with Excellent Heat Resistance, Stability, Improved Resistance to Ingress of Flux.

■FEATURES

1. Small and thin size available-just 2.5(W) × 3.2(L) × 1.25 (H) mm.
2. New shape of cover can improve the flux invasion compared with TZV series.
3. Improvement of the adhesion between rotor and stator leads very small capacitance drift and superior stability.
4. Unique construction with no plastic material provides superior soldering heat resistance to maintain excellent characteristic performance after reflow soldering.
5. Additionally designed capacitance range of 25pF, 45pF as high capacitance value. TZVY2 can cover various requirements by lined-up 6 versions.
6. Including the fixed capacitor, built-in capacitor in parallel with trimmer capacitor type is also available. It makes reduction of space and cost of mounting in circuit. Please contact us about the capacitance value of built-in capacitor.

■APPLICATIONS

- Crystal oscillators, Crystal filters
- Remote keyless Entry systems
- Watches
- Cordless telephones
- Camcorders
- Hand-held telephones
- Hand radios
- Radar detectors
- Pagers

■PART NUMBERING

(Please specify the part number when ordering.)

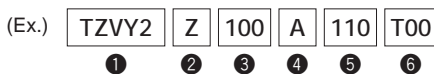

- ① Model Number
- ② Temperature Coefficient Characteristics
- ③ Maximum Capacitance Value
- ④ Terminal Style
- ⑤ Other Specification 110:Standard
- ⑥ Packaging Code T00:Taping 2,000pcs./reel (180mm dia.)
T01:Taping 10,000pcs./reel (330mm dia.)
No Code: Bulk Package 500pcs./bag

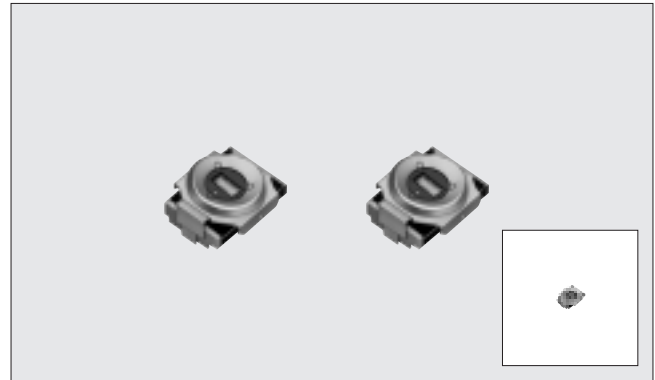

■CONSTRUCTION

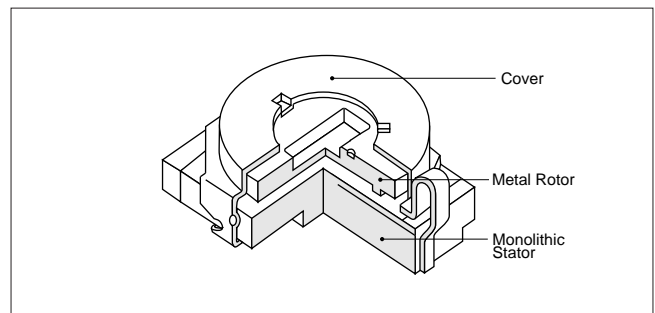

■DIMENSIONS/STANDARD LAND PATTERNS

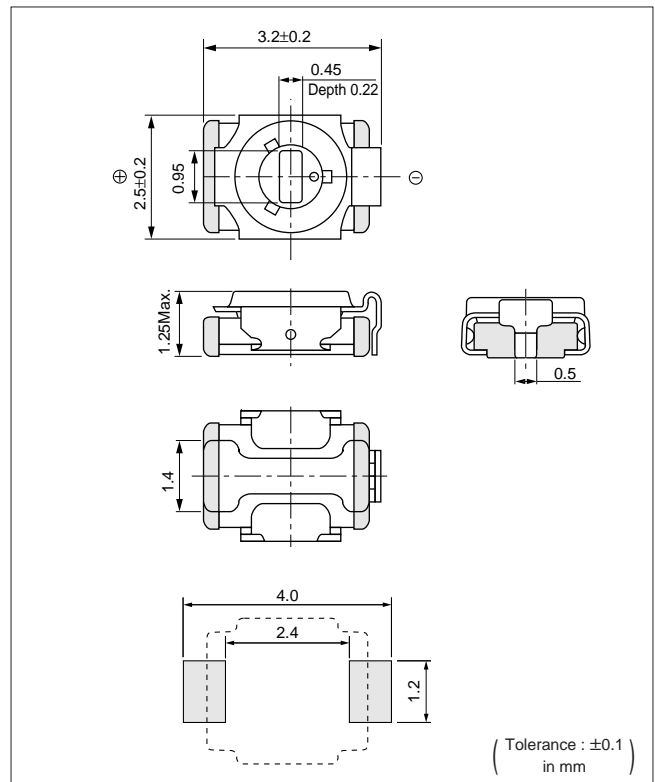

■ RATINGS

Part Number	Capacitance (pF)		Temperature Coefficient (ppm/°C)	Q <1MHz, Cmax.>	Stator Color
	Min. (max.)	Max. ($\pm 100\%$)			
TZVY2Z030A110	1.5	3.0	NP0 ± 300 (0 ± 300)	300 min.	Light Green
TZVY2Z060A110	2.5	6.0	NP0 ± 300 (0 ± 300)	500 min.	Light Green
TZVY2Z100A110	3.0	10.0	NP0 ± 300 (0 ± 300)	500 min.	Light Green
TZVY2R200A110	4.5	20.0	N750 ± 500 (-750 ± 500)	500 min.	Brown
TZVY2R250A110	5.5	25.0	N750 ± 500 (-750 ± 500)	300 min.	Brown
TZVY2P450A110	8.0	45.0	N1000 ± 500 (-1000 ± 500)	300 min.	Light Brown

- Rated Voltage:25Vdc •Withstanding Voltage:55Vdc •Insulation Resistance:10⁴MΩmin.
- Driving Torque:0.5 to 5.0 mN·m (Ref. 5 to 50g·cm) •Working Temperature Range:-25 to +85°C

■ CHARACTERISTICS

• Temperature Coefficient Characteristics

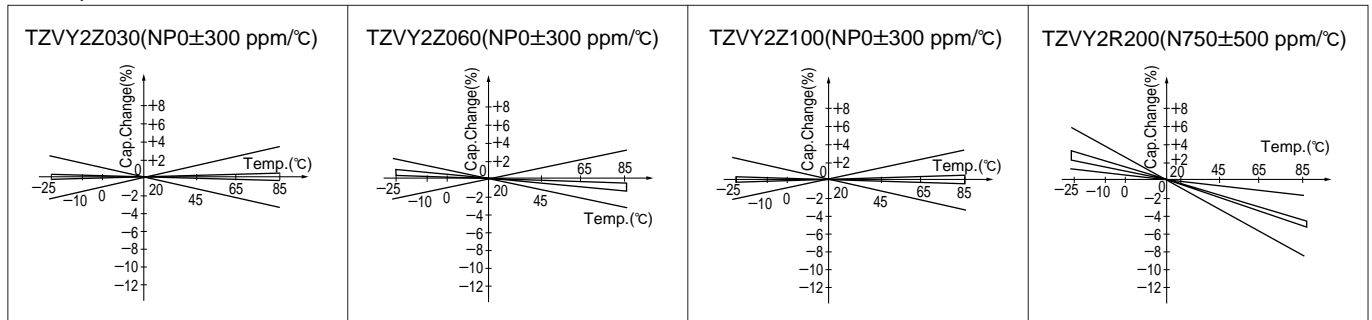

• Q and Capacitance vs. Frequency Characteristics

Characteristics are measured at the maximum rated capacitance value position.

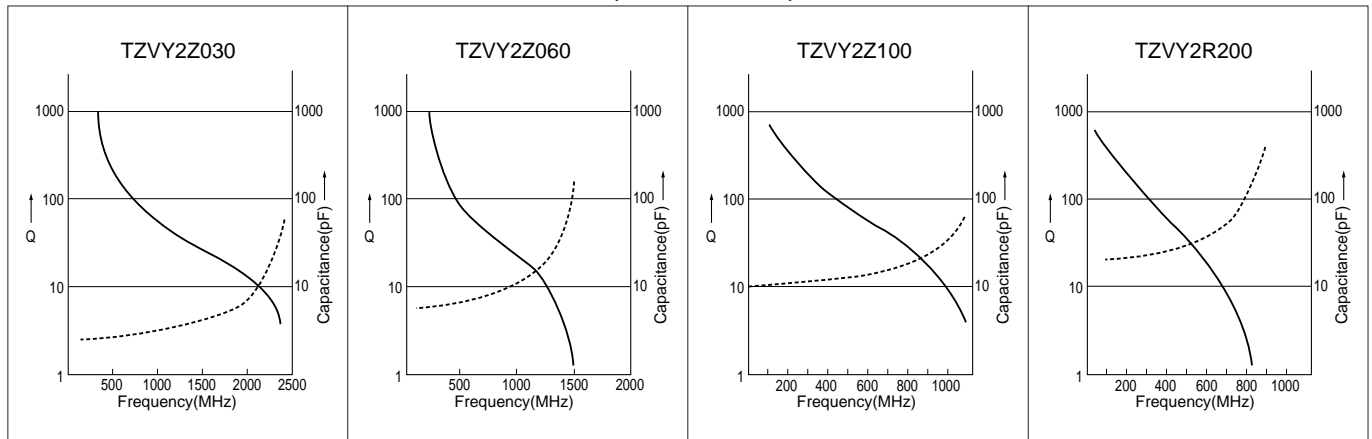

Q : Solid line Capacitance : Dotted line

■ TAPING SPECIFICATIONS / HANDLING PRECAUTIONS / SOLDERING CONDITIONS

- See pages 19 to 21.



CHIP TRIMMER CAPACITOR



Chip Ceramic Trimmer Capacitor **TZVX2/TZV02** Series

Chip Trimmer Capacitor with Excellent Heat Resistance and Stability Characteristics

■FEATURES

1. Small and thin size available-just 2.3(W)×3.2(L)×1.2(H)mm. (TZVX2 Series)
Miniature size with external dimensions of 2.3(W)×3.2(L)×1.45(H)mm. (TZV02 Series)
2. Unique construction with no plastic material provides superior soldering heat resistance to maintain excellent characteristic performance after reflow soldering.
3. Mountable by automatic placer.
4. Pierced square hole allows for high resistance to tuning force and in-process automatic adjustment. (TZVX2 Series)
Funnel shaped metal case enable in-process automatic adjustment.

■APPLICATIONS

- Crystal oscillators , Crystal filters
- Pagers
- Cordless telephones
- Hand-held telephones , Automotive telephones
- Camcorders
- Hand radios
- Remote keyless entry systems
- Radar detectors

■PART NUMBERING

(Please specify the part number when ordering.)

(Ex.)

TZV	□	2	Z	060	A	110	T00
	①	②	③	④	⑤	⑥	

- ① Model Number : TZVX2 or TZV02
- ② Temperature Coefficient Characteristics
- ③ Capacitance Value
- ④ Terminal Style
- ⑤ Other Specification 110 : Standard
- ⑥ Packaging Code

Part Number	T00 : Taping (φ180mm)	T01 : Taping (φ330mm)	No Code : Bulk Package
TZVX2	2,000pcs./reel	10,000pcs./reel	500pcs./bag
TZV02	2,000pcs./reel	8,000pcs./reel	



■CONSTRUCTION

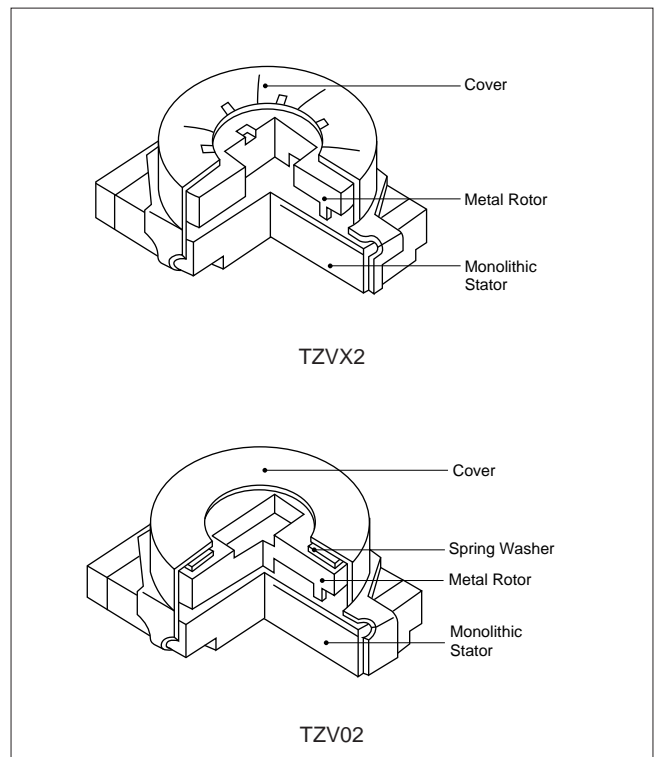

■ DIMENSIONS/STANDARD LAND PATTERNS

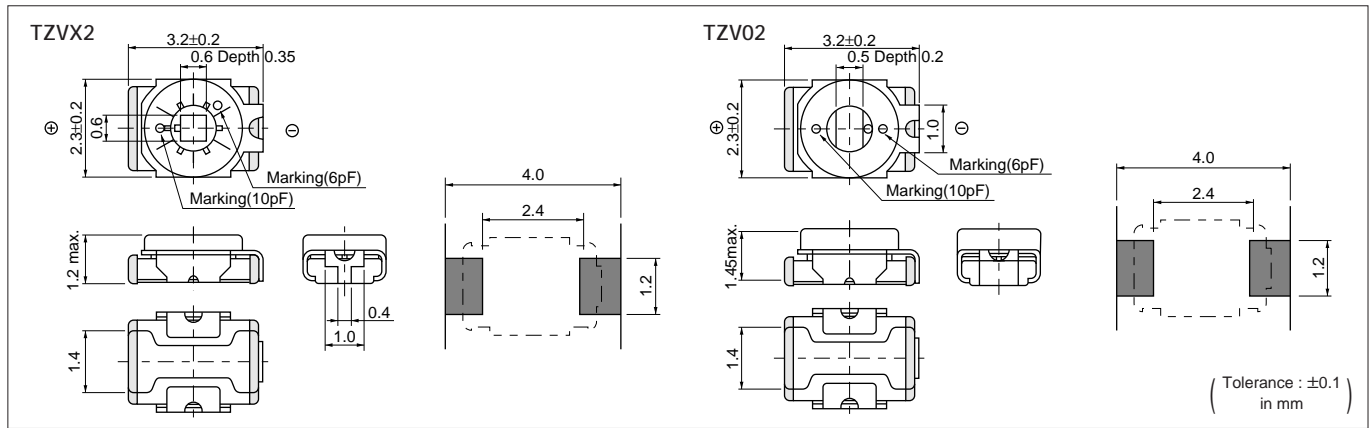

■ RATINGS

Part Number	Capacitance (pF)		Temperature Coefficient (ppm/°C)	Q <1MHz, Cmax.>	Stator Color
	Min. (max.)	Max. (±10%)			
TZV□2Z2R5A110	0.65	2.5	NP0 ±300 (0±300)	200 min.*	White
TZV□2Z030A110	1.5	3.0	NP0 ±300 (0±300)	300 min.	Light Green
TZV□2Z060A110	2.5	6.0	NP0 ±300 (0±300)	500 min.	Light Green+Marking
TZV□2Z100A110	3.0	10.0	NP0 ±300 (0±300)	500 min.	Light Green+Marking
TZV□2R200A110	4.5	20.0	N750±500 (-750±500)	500 min.	Brown

•Rated Voltage:25Vdc •Withstanding Voltage:55Vdc •Insulation Resistance:10⁴MΩmin. *at 200MHz(Z2R5 only)
 •Driving Torque:1.0 to 10.0 mN·m (Ref.10 to 100g·cm) •Working Temperature Range:-25 to +85°C

■ CHARACTERISTICS

● Temperature Coefficient Characteristics

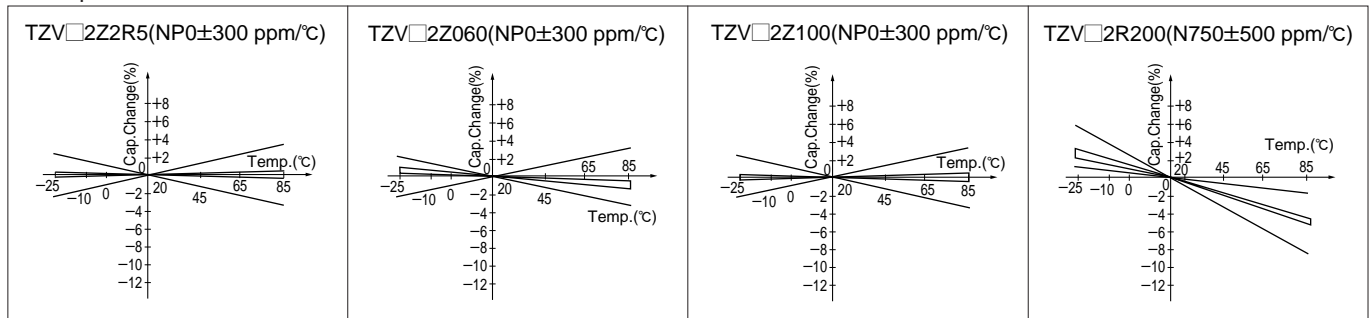

● Q and Capacitance vs. Frequency Characteristics

Characteristics are measured at the maximum rated capacitance value position.

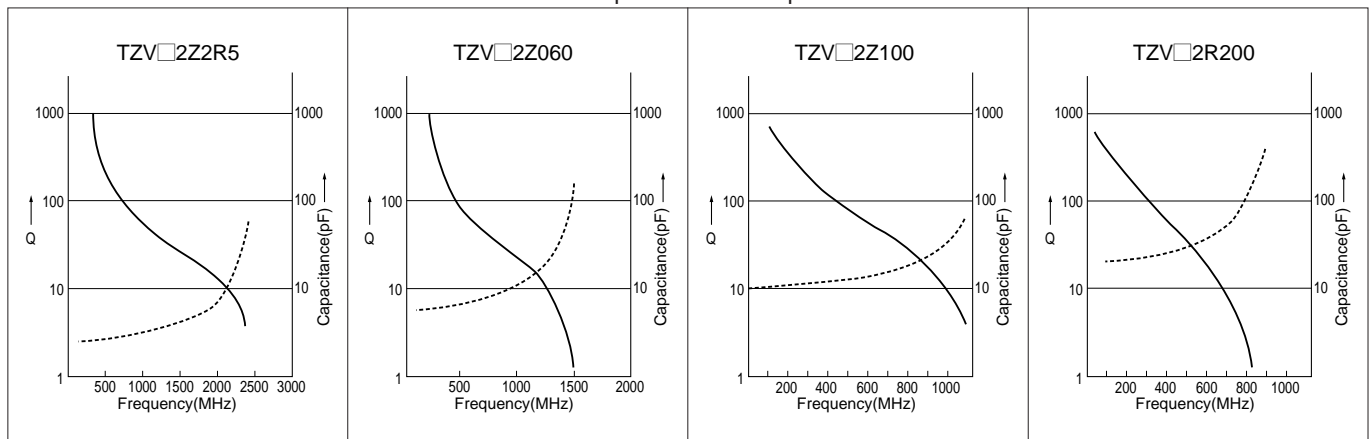

Q : Solid line Capacitance : Dotted line

■ TAPING SPECIFICATIONS / HANDLING PRECAUTIONS / SOLDERING CONDITIONS

● See pages 19 to 21.



CHIP TRIMMER CAPACITOR



Chip Ceramic Trimmer Capacitor **TZC03** Series

Chip Trimmer Capacitor with Minus & Cross Slot.

■FEATURES

1. Small size:3.2(W)×4.5(L)×1.6(H)mm.
(Cross slot type:1.7(H)mm)
2. Color coded stator permits easy identification of capacitance and reduces mounting errors.
3. Can be adjusted with conventional adjustment tools (Standard type) having a thickness of 0.5mm.
4. Available for cross slot type to provide better adjustability.
5. Providing mechanism to prevent air leak offers better mountability with automatic mounter.(Cross slot type)
6. Designed for automatic placement in surface mount applications.
7. Heat resistant resin withstands reflow soldering temperatures.

■APPLICATIONS

- Compact radios, Headphones stereos
- Pagers
- Camcorders
- Mobile telephones
- Hybrid ICs
- Cordless telephones
- Portable radio equipment

■PART NUMBERING

(Please specify the part number when ordering.)

(Ex.)

TZC03	Z	060	A	110	T00
①	②	③	④	⑤	⑥

- ① Model Number
- ② Temperature Coefficient Characteristics
- ③ Capacitance Value
- ④ Terminal Style
- ⑤ Other Specifications 110:Standard Type (Minus Slot)
 310:Cross Slot Type
- ⑥ Packaging Code T00:Taping 1,000pcs./reel (180mm dia.)
 T01:Taping 4,000pcs./reel (330mm dia.)
 No Code:Bulk Package 500pcs./bag

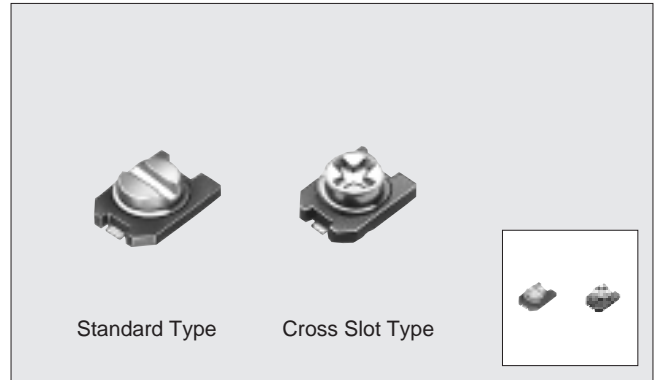

■CONSTRUCTION

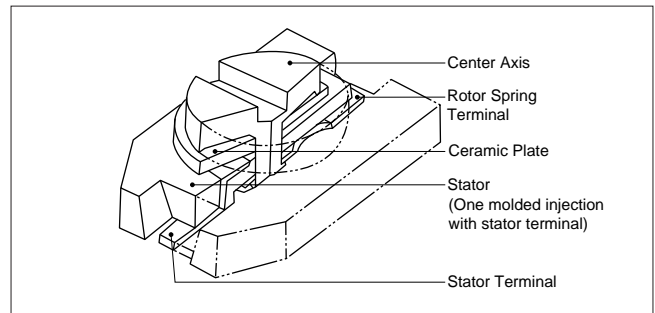

■ DIMENSIONS/STANDARD LAND PATTERNS

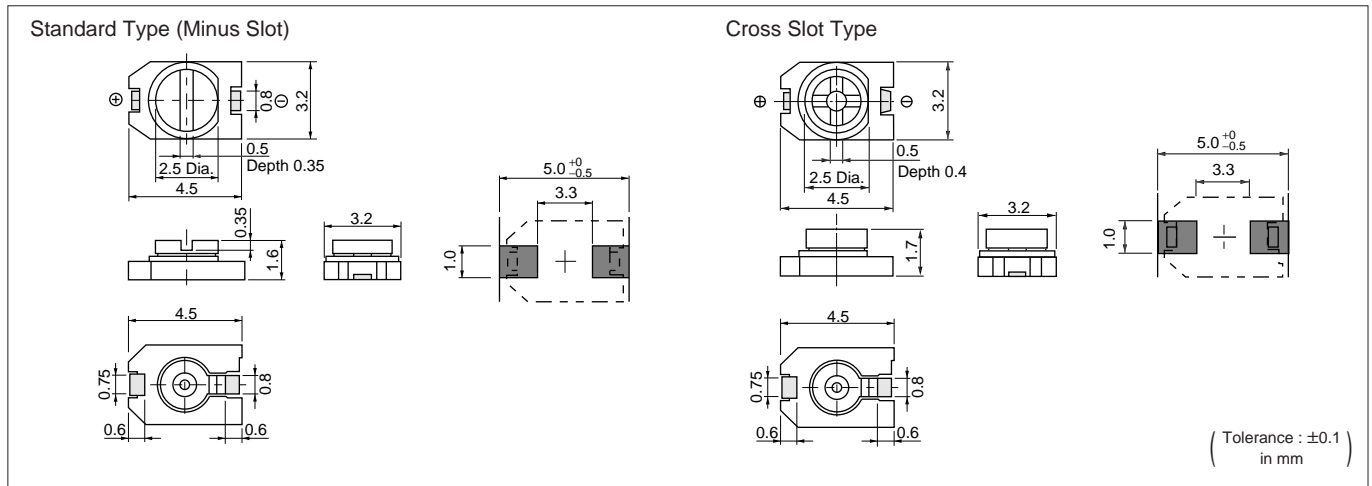

■ RATINGS

Part Number	Capacitance (pF)		Temperature Coefficient (ppm/°C)	Q <1MHz, Cmax.>	Stator Color
	Min. (max.)	Max. (±50%)			
TZC03Z030□□□□	1.4	3.0	NP0 ±300 (0±300)	300 min.	Brown
TZC03Z060A□□□□	2.0	6.0	NP0 ±300 (0±300)	500 min.	Blue
TZC03R100A□□□□	3.0	10.0	N750 ±300 (-750±500)	500 min.	White
TZC03P200A□□□□	5.0	20.0	N1200±500 (-1200±500)	300 min.	Red
TZC03P300A□□□□	6.5	30.0	N1200±500 (-1200±500)	300 min.	Green

- Rated Voltage:100Vdc •Withstanding Voltage:220Vdc •Insulation Resistance:10⁴MΩmin.
- Driving Torque:1.5 to 10.0 mN·m (Ref.15 to 100g·cm) •Working Temperature Range:-25 to +85°C

■ CHARACTERISTICS

● Temperature Coefficient Characteristics

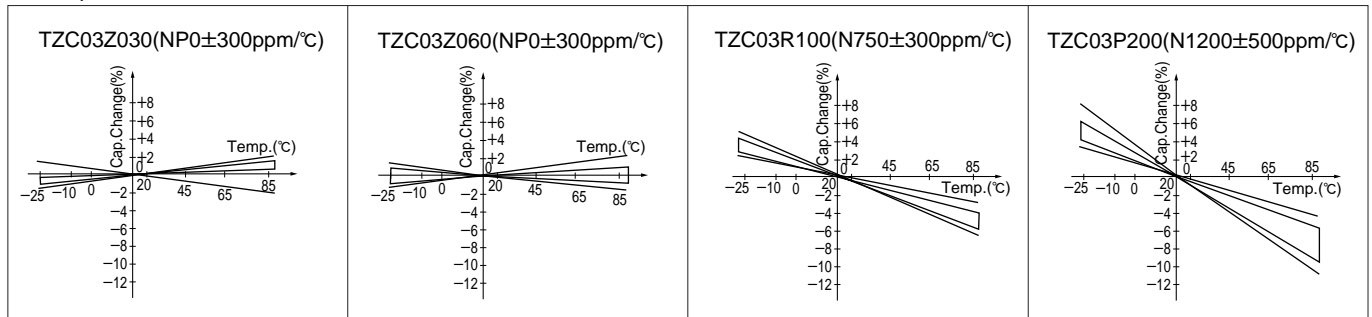

● Q and Capacitance vs. Frequency Characteristics
Characteristics are measured at the maximum rated capacitance value position.

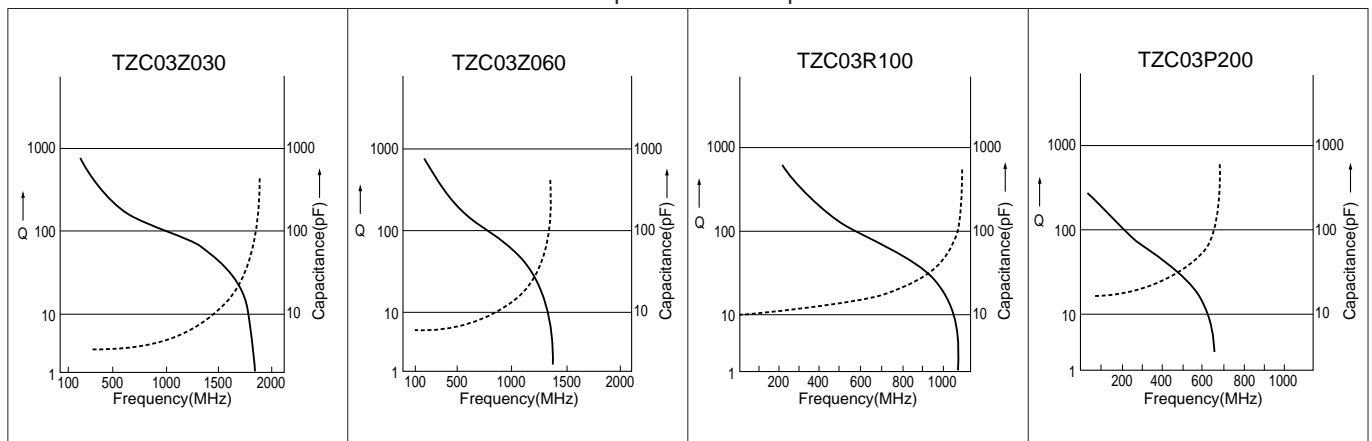

Q : Solid line Capacitance : Dotted line

■ TAPING SPECIFICATIONS / HANDLING PRECAUTIONS / SOLDERING CONDITIONS

- See pages 19 to 21.



CHIP TRIMMER CAPACITOR



Chip Ceramic Trimmer Capacitor TZBX4 Series

Color-coded Case Facilitates Identification Wide Variation with 4mm Package

FEATURES

1. Color-coded case facilitates identification of capacitance range.
2. Miniature rectangular shape : 4.0(W)×4.5(L)×3.0(H)mm.
3. Specifically designed for automatic surface placement.
4. Designed to withstand flux baths and solder baths. (cover film type)
5. Can be temporarily attached to PCB with adhesives. (terminal styles A and B)
6. Can be reflow and flow soldered.
7. Stable characteristics over a wide frequency range. (resonant frequency : 1000 MHz min./6pF)

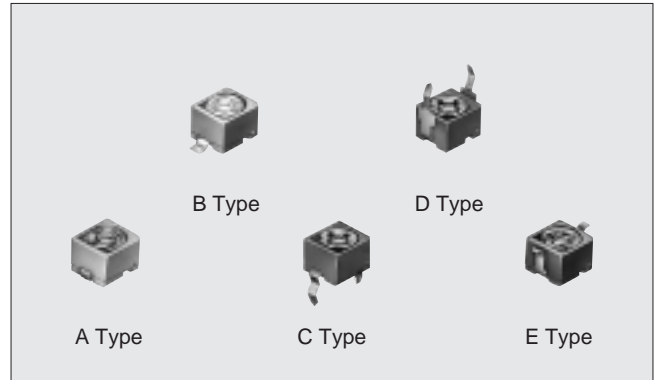

APPLICATIONS

- Camcorders
- Cordless telephones
- Mobile telephones, Car telephones
- Pagers
- Personal computers
- Car audio systems
- Hybrid circuits
- Other compact electronic equipment

PART NUMBERING

(Please specify the part number when ordering.)



- ① Model Number
- ② Temperature Coefficient Characteristics
- ③ Capacitance Value
- ④ Cover Film
(A: not provided, B: provided)
- ⑤ Terminal Style
(A, B, C, D and E Type)
- ⑥ Other Specifications 110: Standard
- ⑦ Packaging Code
(Tape and reel package is available for terminal styles A, B and E.)
T00: Taping 500pcs./reel(180mm dia.)
T02: Taping 2,500pcs./reel(330mm dia.)
No Code: Bulk Package 500pcs./bag

CONSTRUCTION

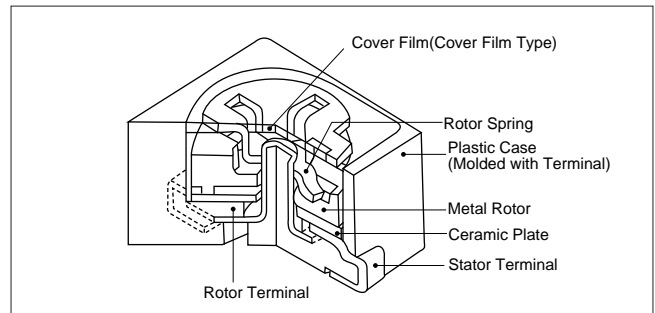

MARKING (Black case only)

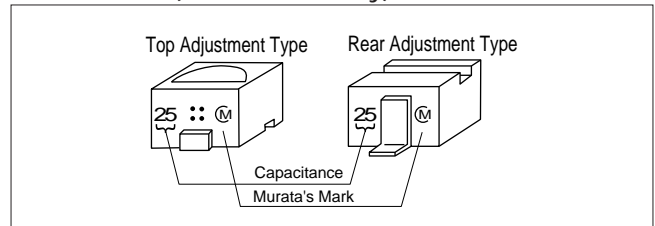

■ DIMENSIONS/STANDARD LAND PATTERNS

● Terminal Shape A Type
(Top Adjustment)

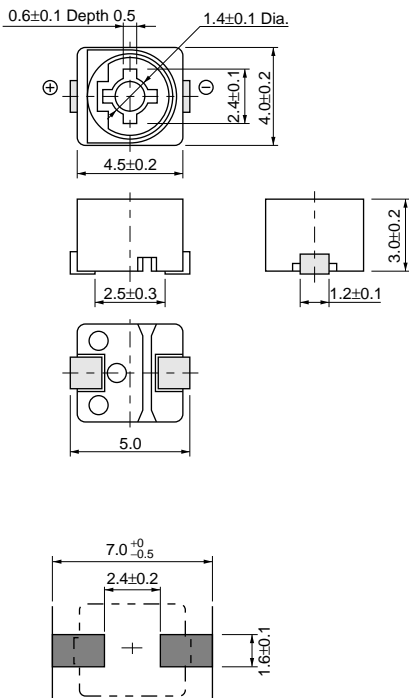

● Terminal Shape B Type
(Top Adjustment)

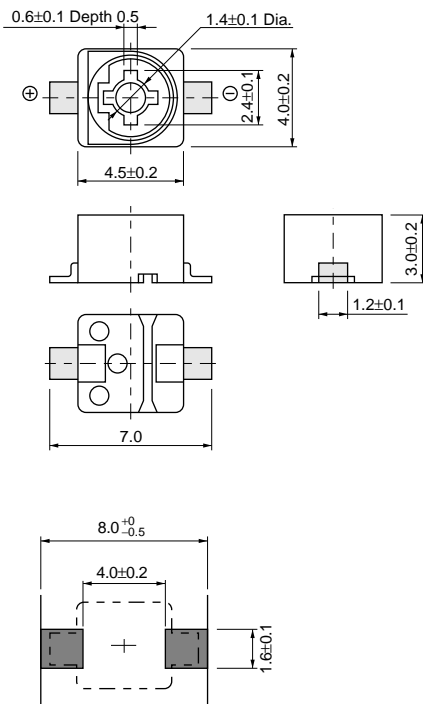

● Terminal Shape C Type
(Top Adjustment)

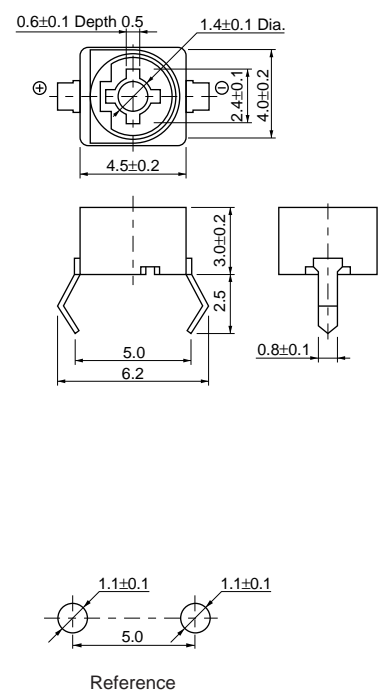

● Terminal Shape D Type
(Rear Adjustment)

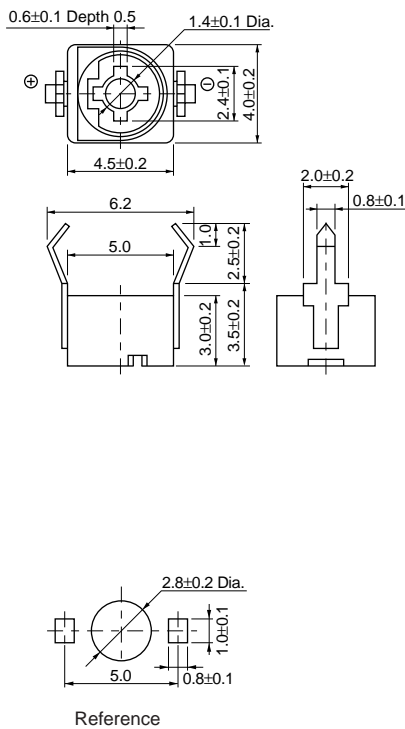

● Terminal Shape E Type
(Rear Adjustment)

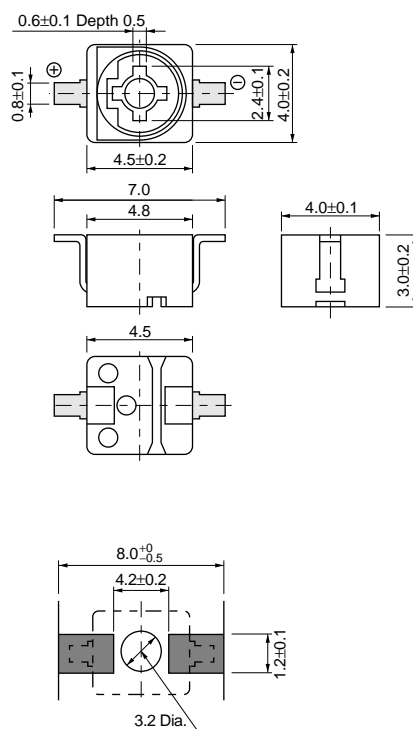

Tape and reel package is available for terminal styles A,B and E.

(Tolerance : ± 0.5 in mm)

■ RATINGS FOR SINGLE PLATE TYPE

Part Number	Capacitance (pF)		Temperature Coefficient (ppm/°C)	Q <1MHz, Cmax.>	Case Color
	Min. (max.)	Max. (±5%)			
TZBX4Z030□□110	1.4	3.0	NP0 ±200 (0±200)	300 min.	Brown
TZBX4Z060□□110	2.0	6.0	NP0 ±200 (0±200)	500 min.	Blue
TZBX4Z100□□110	3.0	10.0	NP0 ±300 (0±300)	500 min.	White
TZBX4R200□□110	4.5	20.0	N750 ±400 (-750±400)	500 min.	Red
TZBX4P300□□110	6.5	30.0	N1200±500 (-1200±500)	300 min.	Green
TZBX4P400□□110	8.5	40.0	N1200±500 (-1200±500)	300 min.	Yellow

- Rated Voltage:100Vdc •Withstanding Voltage:220Vdc •Insulation Resistance:10⁴MΩmin.
- Driving Torque:1.5 to 10.0 mN·m (Ref.15 to 100g·cm) •Working Temperature Range:-25 to +85°C

■ RATING FOR MONOLITHIC PLATE TYPE

Part Number	Capacitance (pF)		Temperature Coefficient (ppm/°C)	Q <1MHz, Cmax.>	Case Color
	Min. (max.)	Max. (±10%)			
TZBX4Z250□□110	4.0	25.0	NP0 ±300 (0±300)	300 min.	Black+Marking
TZBX4R500□□110	7.0	50.0	N750±300 (-750±300)	300 min.	Black+Marking

- Rated Voltage:50Vdc •Withstanding Voltage:110Vdc •Insulation Resistance:10⁴MΩmin.
- Driving Torque:1.5 to 10.0 mN·m (Ref.15 to 100g·cm) •Working Temperature Range:-25 to +85°C

■ CHARACTERISTICS

- Temperature Coefficient Characteristics

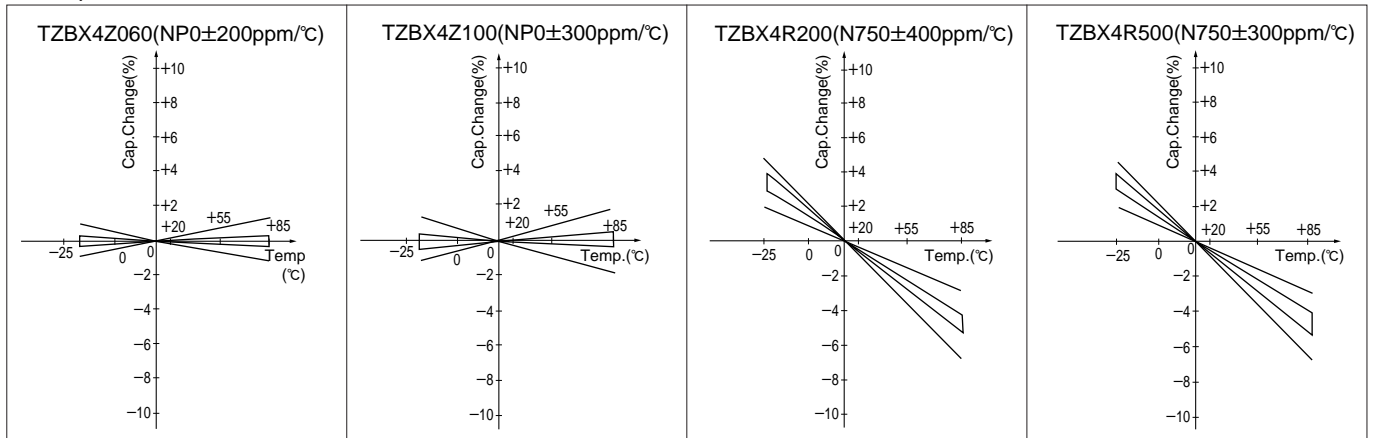

- Frequency Characteristics

Characteristics are measured at the maximum rated capacitance value position.

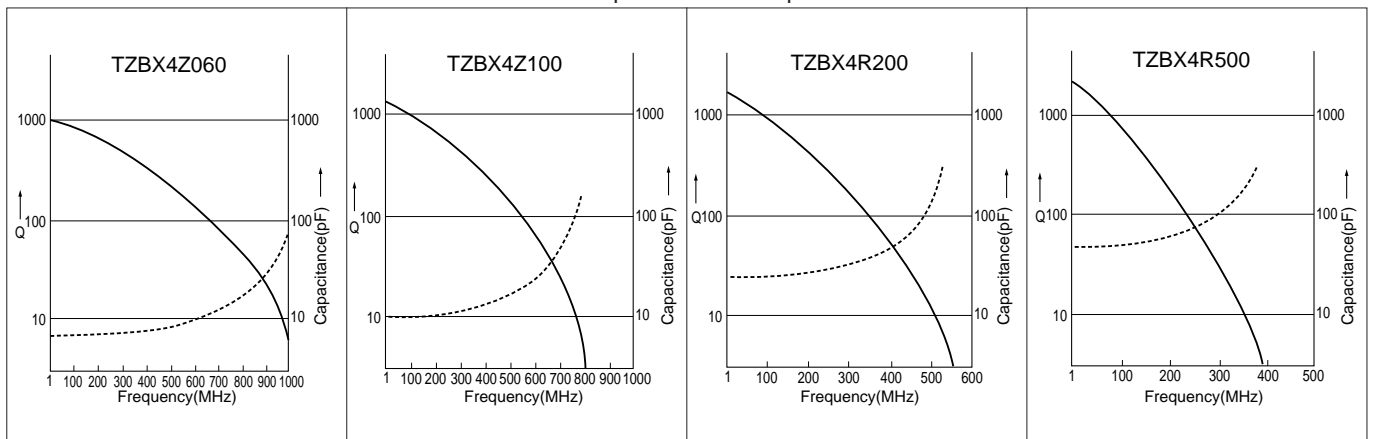

Q : Solid line Capacitance : Dotted line

■ TAPING SPECIFICATIONS / HANDLING PRECAUTIONS / SOLDERING CONDITIONS

- See pages 19 to 21.



CERAMIC TRIMMER CAPACITOR



Ceramic Trimmer Capacitor TZ03 Series

Automatic Insertion and Automatic Adjustment Color-coded Plastic Case with 6mm Package

FEATURES

1. Color coded case permits easy identification.
2. Sealed construction prevents the penetration of flux and dust.
3. Available in three adjustment styles : Top/Rear/Side.
4. Available in both tape and reel and magazine packaging for automatic insertion.
- 5.+(Cross-shaped) slot enables automatic adjustment.

APPLICATIONS

- VCRs, LD players, CTV sets
- Car audio systems, Car clocks
- Radio cassette tape Recorders, Stereos
- Cordless telephones, Transceivers
- Personal computers, Video games, Facsimiles

PART NUMBERING

(Please specify the part number when ordering.)

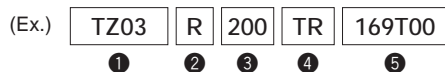

- ① Model Number
- ② Temperature Coefficient Characteristics
- ③ Capacitance Value
- ④ Terminal Style (TR : radial taping package)
- ⑤ Packaging Code
 - 169 : Bulk Package 1,000pcs./bag (500pcs./bag for YR style)
 - 194 : Magazine Package 80pcs./magazine
 - 169T00 : Radial Taping Package 1,000pcs./ammo pack

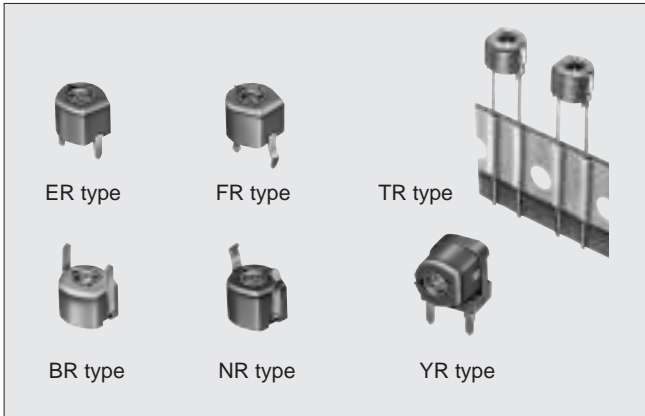

CONSTRUCTION

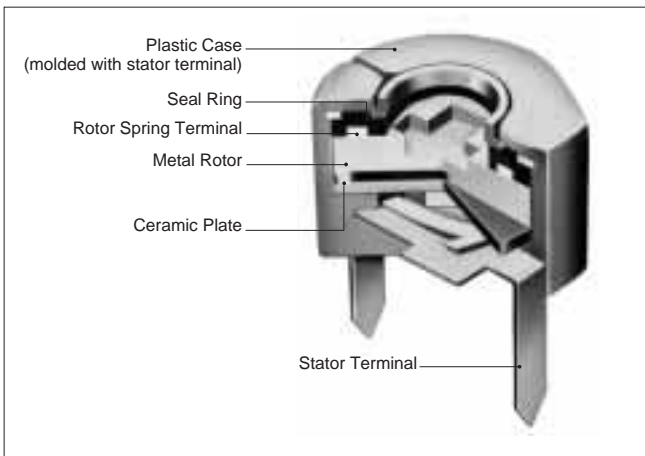

■ OUTLINE DIMENSIONS / STANDARD PCB LAYOUT

● Top Adjustment

● Rear Adjustment

Terminal Style : ER

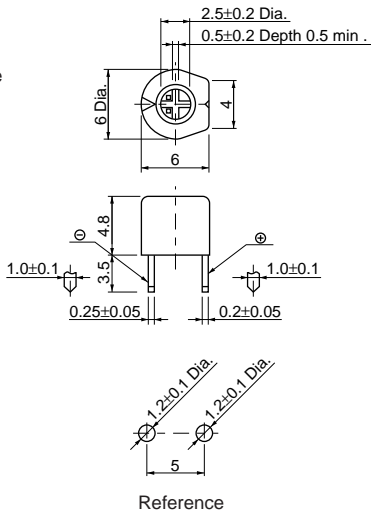

Terminal Style : BR

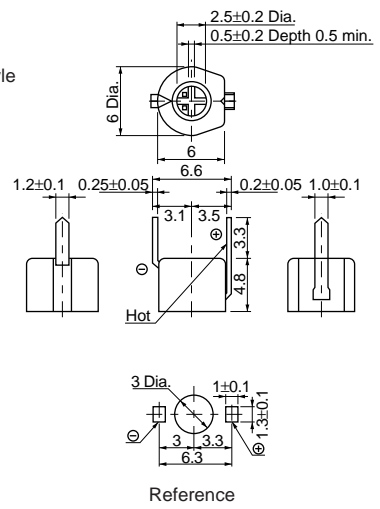

Terminal Style : FR

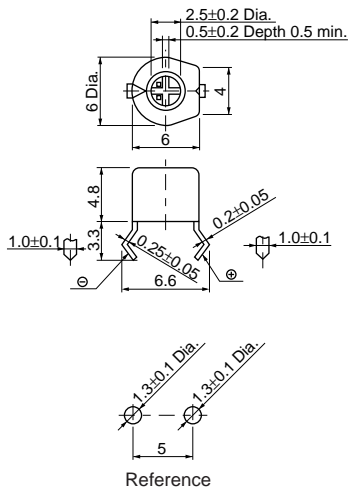

Terminal Style : NR

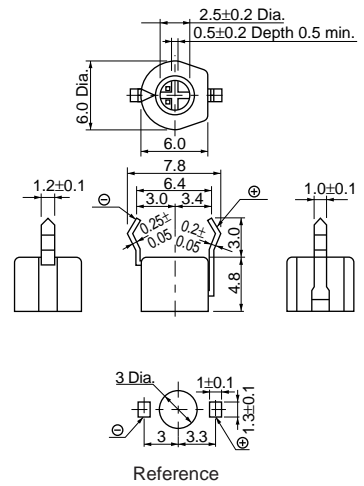

● Side Adjustment

● Radial Taping

Terminal Style : YR

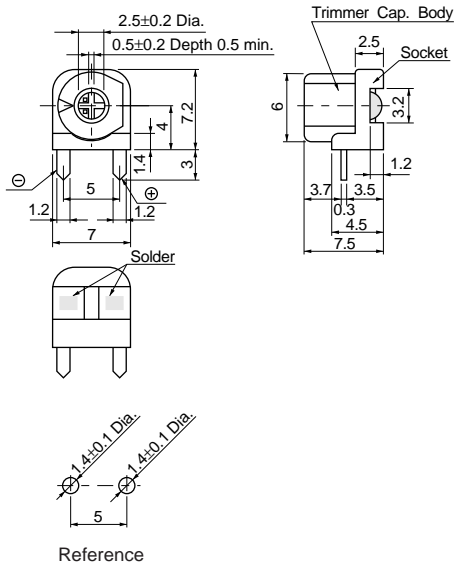

Terminal Style : TR

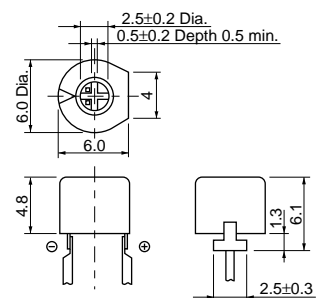

(Tolerance : ±0.5 in mm)

■ RATINGS FOR SINGLE PLATE TYPE

Part Number	Capacitance (pF)		Temperature Coefficient (ppm/°C)	Q <1MHz, Cmax.>	Case Color
	Min. (max.)	Max. (±5%)			
TZ03Z2R3□169	1.25	2.3	NP0 ±200 (0±200)	300 min.	Black
TZ03Z050□169	1.5	5.0	NP0 ±200 (0±200)	500 min.	Blue
TZ03Z070□169	2.0	7.0	NP0 ±200 (0±200)	500 min.	Blue
TZ03Z100□169	2.7	10.0	NP0 ±200 (0±200)	500 min.	Blue
TZ03N100□169	2.1	10.0	N200 ±200 (-200±200)	500 min.	White
TZ03T110□169	3.0	11.0	N450 ±300 (-450±300)	500 min.	White
TZ03T200□169	4.2	20.0	N450 ±300 (-450±300)	500 min.	Pink
TZ03R200□169	4.2	20.0	N750 ±300 (-750±300)	500 min.	Red
TZ03R300□169	5.2	30.0	N750 ±300 (-750±300)	500 min.	Green
TZ03P450□169	6.8	45.0	N1200±500 (-1200±500)	300 min.	Yellow
TZ03P600□169	9.8	60.0	N1200±500 (-1200±500)	300 min.	Brown

- Stray capacitance for side adjustment type adapter (YR) is 0.2pF.
- Insulation resistance : 10¹⁰MΩmin.
- Rated voltage : 100Vdc
- Withstanding voltage : 220Vdc
- Driving Torque : 2.0 to 15.0mN·m (Ref.20 to 150gf·cm)
- Working Temperature Range : -25 to +85°C

■ RATING FOR MONOLITHIC PLATE TYPE

Part Number	Capacitance (pF)		Temperature Coefficient (ppm/°C)	Q <1MHz, Cmax.>	Case Color
	Min. (max.)	Max. (±10%)			
TZ03Z500□169	6.0	50.0	NP0 ±300 (0±300)	300 min.	Orange
TZ03R900□169	9.0	90.0	N750±300 (-750±300)	300 min.	Black+Marking
TZ03R121□169	10.0	120.0	N750±300 (-750±300)	300 min.	Black

- Stray capacitance for side adjustment type adapter (YR) is 0.2pF.
- Insulation resistance : 10¹⁰MΩmin.
- Rated voltage : 50Vdc
- Withstanding voltage : 110Vdc
- Driving Torque : 2.0 to 15.0mN·m (Ref. 20 to 150gf·cm)
- Working Temperature Range : -25 to +85°C

■ RADIAL TAPING PACKAGE

- Part number : TZ03□○○○TR169T00
- Standard packaging : 1,000 pcs. / ammo pack

Flat Pack Outline

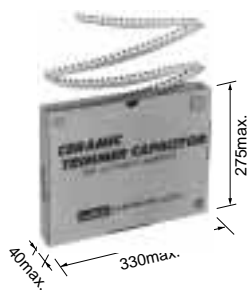

Taping Dimensions

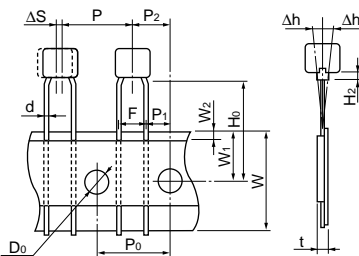

Item	Code	Dimensions (mm)	Remark
Pitch of Component	P	12.7	Tolerance with ΔS
Pitch of Sprocket Hole	P ₀	12.7±0.3	
Length from Hole	P ₁	3.85±0.7	
Center to Lead	P ₂	6.35±1.3	
Lead Spacing	F	5.0±0.2	
Carrier Tape Width	W	18.0±0.5	
Position of Sprocket Hole	W ₁	9.0±0.5	
Hold Down Tape Position	W ₂	1.5±1.5	
Lead Distance between Reference and Bottom Planes	H ₀	18.0±0.5	
Stand-off	H ₂	1.3±0.5	
Diameter of Sprocket Hole	D ₀	4.0±0.1	
Total Thickness, Tape and Lead Wire	t	1.7max.	
Deviation Across Tape	Δh	1.5max	
Deviation Along Tape, Left or Right	ΔS	0±1.5	
Lead Diameter	d	0.6±0.1 dia.	Except 1mm from the Stand-off Position

■ MAGAZINE PACKAGE



Magazine Dimensions

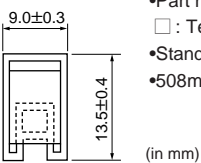

- Part number : TZ03○○○○□194
- : Terminal style (ER / FR / BR)
- Standard packaging : 80pcs./ magazine
- 508mm long

■ HANDLING PRECAUTIONS / SOLDERING CONDITIONS

- See pages 20 to 21.

■ CHARACTERISTICS

● Temperature Coefficient Characteristics

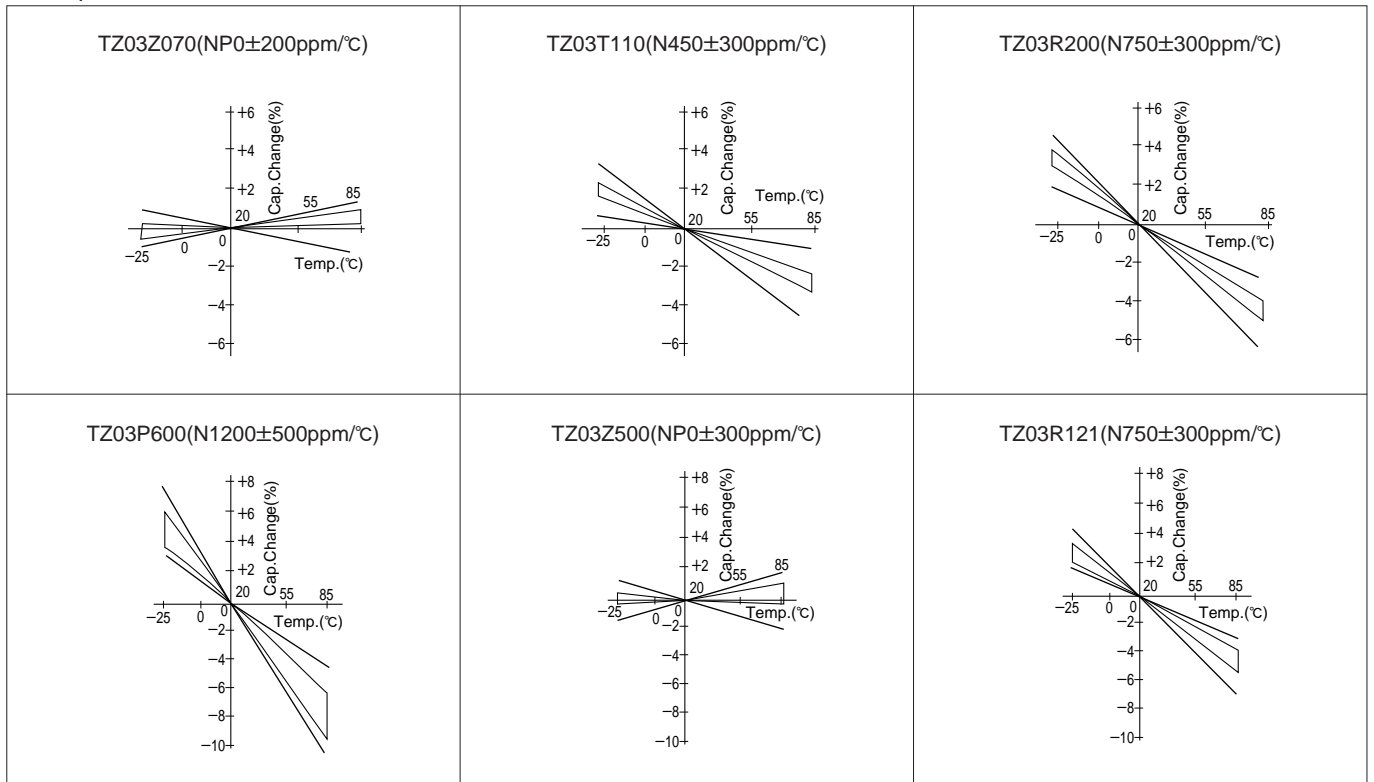

● Frequency Characteristics

Characteristics are measured at the maximum rated capacitance value position.

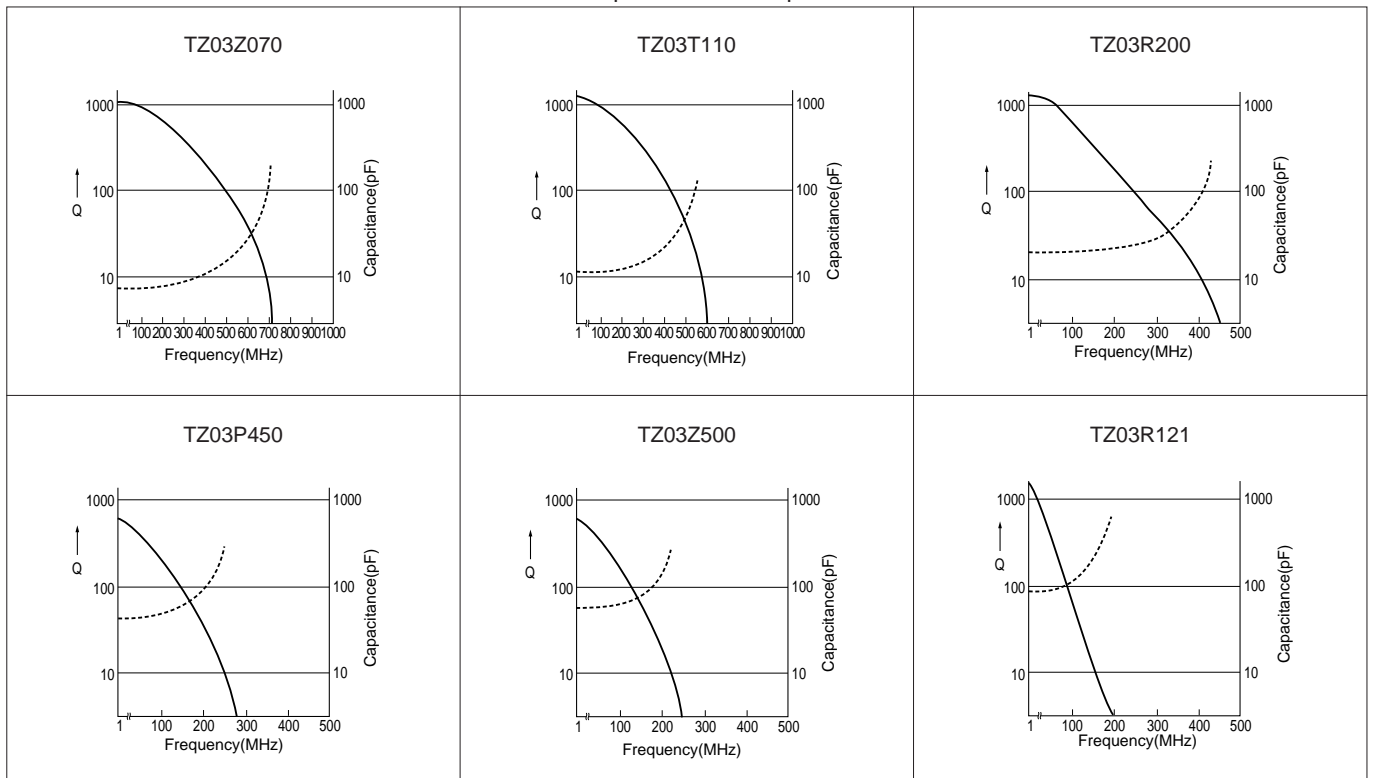

Q : Solid line Capacitance : Dotted line

Taping Dimensions and Minimum Order Quantity of Ceramic Trimmer Capacitor

1. Plastic Tape and Reel Dimensions (TZS02 / TZVY2 / TZVX2 / TZV02 / TZC03 / TZBX4 Series)

(1) Plastic Tape

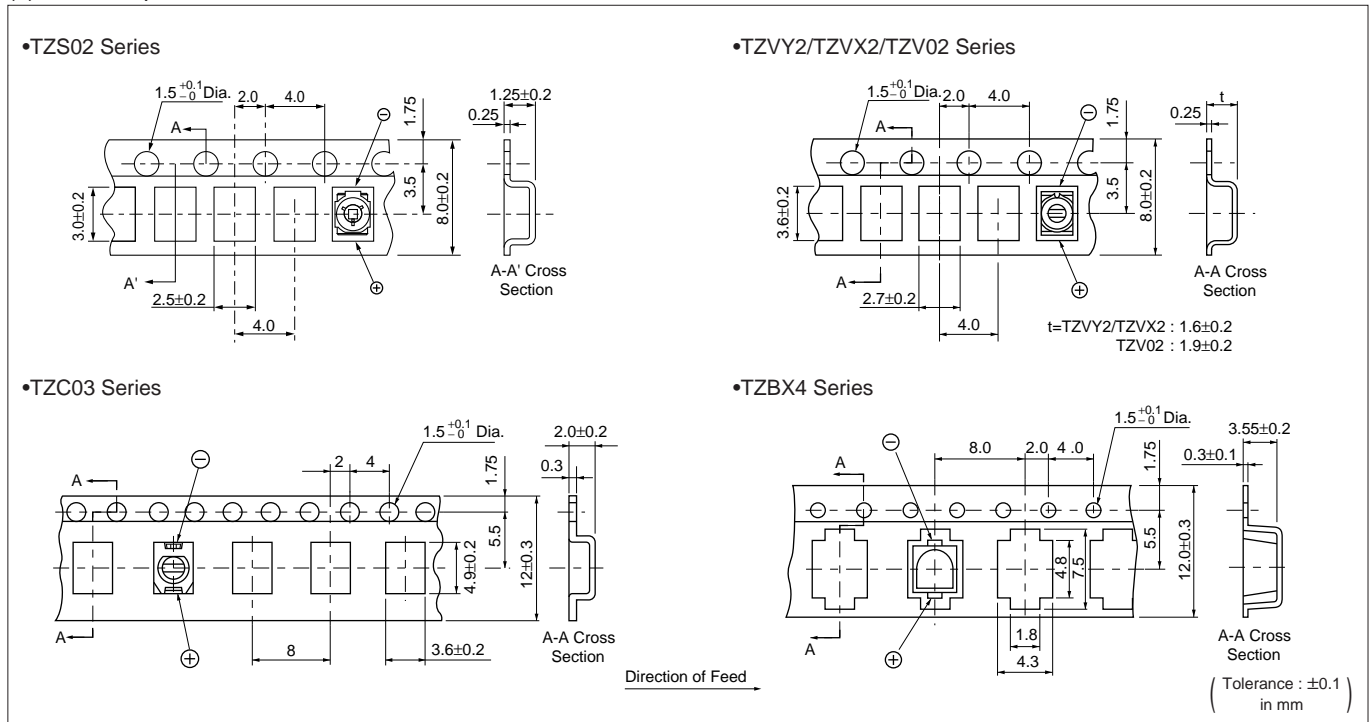

(2) Reel

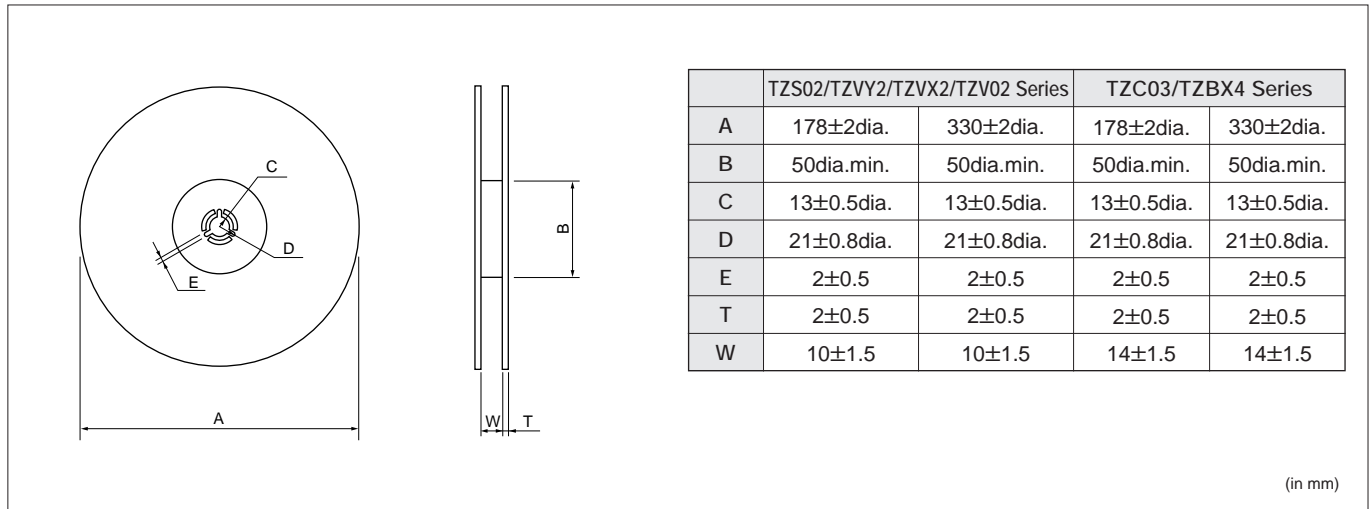

(3) Minimum Order Quantity (order in sets only)

<p>•TZS02 Series</p> <p>3,000pcs. / reel (180mm dia.)</p> <p>10,000pcs. / reel (330mm dia.)</p> <p>500pcs. / bag</p> <p>•TZVY2/TZVX2 Series</p> <p>2,000pcs. / reel (180mm dia.)</p> <p>10,000pcs. / reel (330mm dia.)</p> <p>500pcs. / bag</p> <p>•TZV02 Series</p> <p>2,000pcs. / reel (180mm dia.)</p> <p>8,000pcs. / reel (330mm dia.)</p> <p>500pcs. / bag</p>	<p>•TZC03 Series</p> <p>1,000pcs. / reel (180mm dia.)</p> <p>4,000pcs. / reel (330mm dia.)</p> <p>500pcs. / bag</p> <p>•TZBX4 Series</p> <p>500pcs. / reel (180mm dia.)</p> <p>2,500pcs. / reel (330mm dia.)</p> <p>500pcs. / bag</p> <p>•TZ03 Series</p> <p>1,000pcs. / bag</p> <p>500pcs. / bag (YR style only)</p>
---	---

Notice of Ceramic Trimmer Capacitor

Introduction :

Trimmer capacitors made by MURATA MFG. CO., LTD. are designed to achieve high reliability and cost efficiency. We offer the following usage guidelines to ensure our trimmer capacitors perform effectively and meet your requirements. Rapid innovations will certainly create new applications for our trimmer capacitors. We welcome you to contact us concerning application questions.

1. Mounting Trimmer Capacitors on PCBs

- (1) Ensure that PCB hole spacing complies with the terminal spacing requirement of the intended trimmer capacitor model. Incorrect hole spacing may lower trimmer capacitor performance due to excessive stress applied to the terminal.
- (2) Mount trimmer capacitor in contact with PCB.
- (3) Do not apply bending stress after the trimmer capacitor has been mounted to the PCB. See the stress specification listed below.

Model	Allowable Stress
TZ03/TZBX4 (Terminal Style CZD)	10.0N(Ref.1kgf)

- (4) Note trimmer capacitor polarity to minimize the influence of stray capacitance. Refer to the outlines of each model. (⊕Terminal:Stator side ; ⊖Terminal:Rotor side)
- (5) Do not warp and/or bend PC board to prevent trimmer capacitor from breakage.

2. Soldering

Standard soldering conditions are shown below. Before using soldering conditions other than those listed below, please consult MURATA factory representative. If the soldering conditions are not suitable for the product, the trimmer capacitor may deviate from the specified performances characteristic.

(1) Soldering Iron

	TZS02/TZVY2/ TZVX2/TZV02/TZC03	TZBX4/TZ03
Tip temperature	260°C±10°C	260°C±10°C
Soldering time	3 sec. max.	3 sec. max.
Tip diameter	1mm dia. max.	2mm dia. max.
Iron wattage	20W max.	30W max.

(2) Flow Soldering

- TZBX4 Cover film type
Immerse the body in solder bath
- TZBX4 Terminal style C and D / TZ03 series
Only immerse terminal in solder bath
Refer to the standard temperature profile listed below.

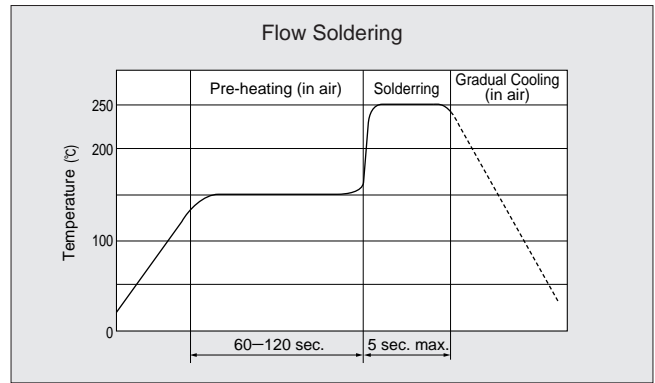

(3) Reflow Soldering

TZS02 / TZVY2 / TZVX2 / TZV02 / TZC03 / TZBX4 series
Refer to the standard temperature profile listed below.

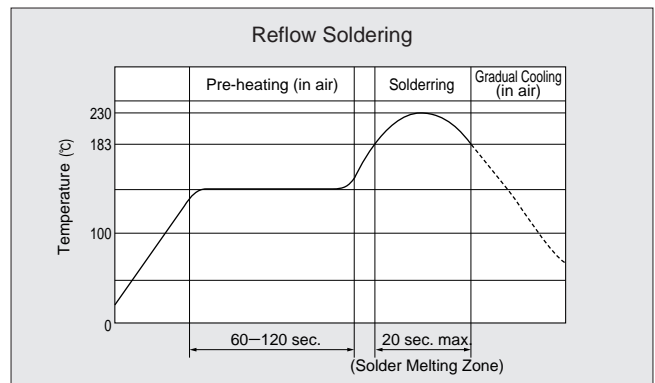

(4) Notice When Soldering

- The solder iron should contact neither the trimmer capacitor's resin case nor its ceramic substrate.
- To prevent the deterioration of trimmer capacitor characteristics, apply flux only to terminals.
- The amount of solder is critical. Insufficient amounts of solder can lead to insufficient soldering strength on the PCB. Excessive amounts of solder may cause bridging between the terminals resulting in terminal shorts.
- Do not use water - soluble flux if using water for washing.
- TZS02 / TZVY2 / TZVX2 / TZV02 / TZC03 / TZBX4 series without cover films can not be soldered using the flow soldering method (dipping).
- TZ03 series can not be soldered using the reflow soldering method.
- When soldering the TZC03 series, the solder should not flow into the staking part of the substrate. If such flow does occur, driver slot rotation will be impeded.
- Use our standard land dimension. Excessive land area causes displacement due to effect of the surface tension of the solder or the contact failure due to flux wicking up. Insufficient land area causes insufficient soldering strength of the chip.

Series	Standard applying thickness
TZS02/TZVY2/TZVX2/TZV02	120-170µm
TZC03	150-200µm
TZBX4	200-250µm

Notice of Ceramic Trimmer Capacitor

3. Cleaning

- TZS02 / TZVY2 / TZVX2 / TZV02 / TZC03 / TZBX4 Series
(without cover film) can not be cleaned because of open construction.

(1) Cleaning Solvents

Isopropyl - alcohol and ethyl - alcohol are satisfactory cleaning agents. Water-based agents like Pinealpha and Cleanthre cannot be used. Before using other agents, please consult a MURATA factory representative.

(2) Cleaning Precautions

① TZBX4 Series (with cover film)

The total cleaning time for either the dipping or vapor method shall not exceed 2 minutes. The total cleaning time for the ultrasonic method shall be less than 1 minute and for the cold dipping method shall be less than 5 minutes.

② TZ03 Series

Cleaning time shall be less than 2 minutes for the dipping method and less than 30 seconds for the ultrasonic method.

③ Ultrasonic Cleaning

Specifications are as follows.

1. Power : 20W / liter max.
2. Frequenc : 28kHz
3. Temperature : Ambient temperature

Many variables are associated with using ultrasonic cleaning equipment such as the equipment's self-resonance point, its jig construction, and cleaning conditions such as the depth of immersion. Therefore, please test cleaning equipment to determine suitable conditions.

4. Adjusting

- (1) To maintain specified performance characteristics, do not apply excessive force (preferably, not exceeding 1.0N (Ref.100g.f)).
- (2) For high-frequency capacitors, use suitable screwdrivers whose thickness is appropriate for the adjustment slot.

(3) Note the following for the TZBX4 series with cover film.

- Do not break the cover film before the completion of PCB mounting, soldering, and cleaning.
- Do not clean the trimmer capacitor after the cover film has been broken.
- To break the cover film, first turn the screwdriver more than 45°, then set the capacitance value. (The cover film cannot be broken by only inserting the screwdriver.)
- Before finding the screwdriver slot, applying pressure on the driver plate should be kept less than 1.96N. Higher pressure leads to extensive setting drift or damage to internal elements.
After finding the screwdriver slot, the applied force should be less than 3.0N (Ref.300gf).

5. External Substances

Do not externally apply silicone or any other substances to the trimmer capacitors to secure adjustment position. This may cause electrical contact problems or trimmer capacitor corrosion.

6. Storage

- (1) Before using trimmer capacitor, please store under the condition of -10 to +40°C and 30 to 85%RH.
- (2) Do not store in or near corrosive gasses.
- (3) Use within 6 months of delivery.
- (4) Do not open the package until just prior to using.
- (5) Prior to storing opened packages, the packaging should be heat sealed. Avoid using rubber bands when repackaging.

7. Note

- (1) Before using trimmer capacitors, please test after assembly in your particular mass production system.
- (2) MURATA cannot guarantee trimmer capacitor integrity when used under conditions other than those specified in this document.

⚠ Note:**1. Export Control**

⟨For customers outside Japan⟩

Murata products should not be used or sold for use in the development, production, stockpiling or utilization of any conventional weapons or mass-destructive weapons (nuclear weapons, chemical or biological weapons, or missiles), or any other weapons.

⟨For customers in Japan⟩

For products which are controlled items subject to the "Foreign Exchange and Foreign Trade Law" of Japan, the export license specified by the law is required for export.

2. Please contact our sales representatives or product engineers before using our products listed in this catalog for the applications listed below which require especially high reliability for the prevention of defects which might directly cause damage to the third party's life, body or property, or when intending to use one of our products for other applications than specified in this catalog.

- ① Aircraft equipment
- ② Aerospace equipment
- ③ Undersea equipment
- ④ Medical equipment
- ⑤ Transportation equipment (vehicles, trains, ships, etc.)
- ⑥ Traffic signal equipment
- ⑦ Disaster prevention / crime prevention equipment
- ⑧ Data-processing equipment
- ⑨ Application of similar complexity and/or reliability requirements to the applications listed in the above

3. Product specifications in this catalog are as of September 1999. They are subject to change or our products in it may be discontinued without advance notice. Please check with our sales representatives or product engineers before your ordering. If there are any questions, please contact our sales representatives or product engineers.**4. The parts numbers and specifications listed in this catalog are for information only. You are requested to approve our product specification or to transact the approval sheet for product specification, before your ordering.****5. Please note that unless otherwise specified, we shall assume no responsibility whatsoever for any conflict or dispute that may occur in connection with the effect of our and/or third party's intellectual property rights and other related rights in consideration of your using our products and/or information described or contained in our catalogs. In this connection, no representation shall be made to the effect that any third parties are authorized to use the rights mentioned above under licenses without our consent.****6. None of ozone depleting substances (ODS) under the Montreal Protocol is used in manufacturing process of us.**