

RIGHT ANGLE PLUG CRIMP OR SOLDER TYPE

R125.176.000

CABLE 5/50 D

Series : SMA

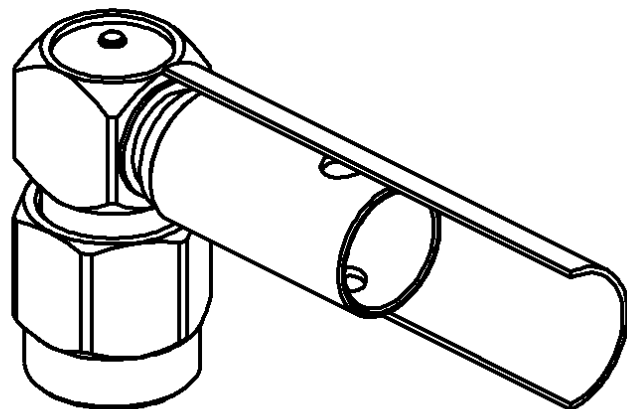
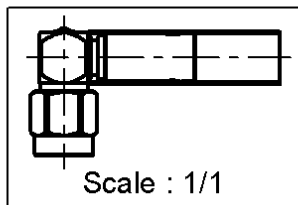
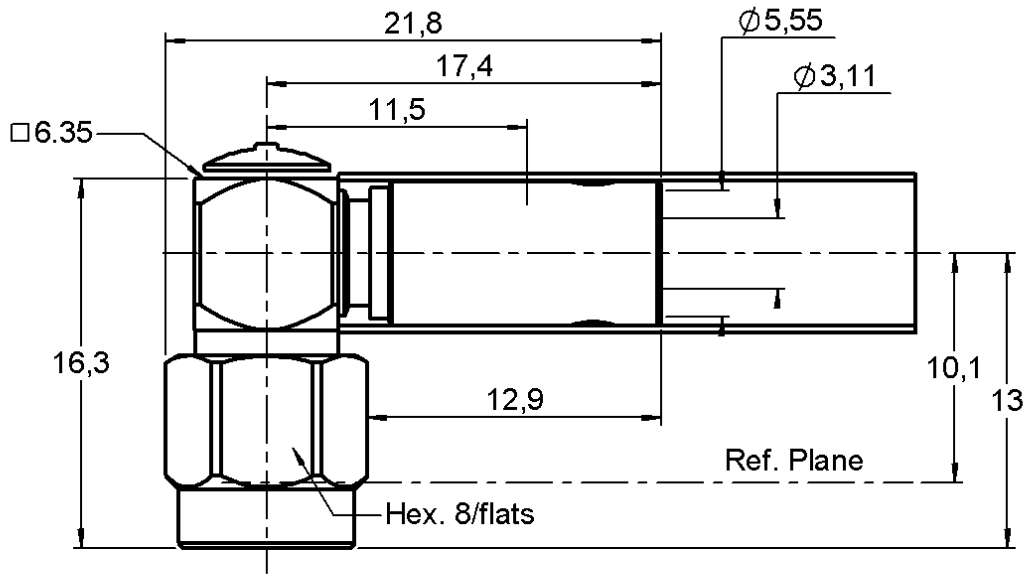

CECC 22111-810/05



All dimensions are in mm.

COMPONENTS	MATERIALS	PLATINGS (µm)
BODY	STAINLESS STEEL	GOLD 0.5 OVER NICKEL 2
CENTER CONTACT	BRASS	GOLD 1.3 OVER NICKEL 2
OUTER CONTACT	-	-
INSULATOR	PTFE	-
GASKET	SILICONE RUBBER	-
OTHERS PARTS	STAINLESS STEEL	GOLD 0.5 OVER NICKEL 2
-	-	-
-	-	-

Issue : 0311 U

In the effort to improve our products, we reserve the right to make changes judged to be necessary.



RIGHT ANGLE PLUG CRIMP OR SOLDER TYPE

R125.176.000

CABLE 5/50 D

Series : SMA

PACKAGING

Standard	Unit	Other
100	'W' option	Contact us

SPECIFICATION

QAE 06-02A - -

ELECTRICAL CHARACTERISTICS

Impedance		50 Ω
Frequency		0-12.4 GHz
VSWR	1.15 +	0.020 x F(GHz) Maxi
Insertion loss		0.15 √F(GHz) dB Maxi
RF leakage	- (60 - F(GHz)) dB Maxi
Voltage rating		335 Veff Maxi
Dielectric withstanding voltage		1000 Veff mini
Insulation resistance		5000 MΩ mini

CABLE ASSEMBLY

Stripping	a	b	c	d	e	f
mm	2.80	7.00	12.8	0.00	10.0	0.00

Assembly instruction : **Crimp 05**

Recommended cable(s)

RG 223
RG 142 FTX
RG 400
RG 142
KX 23

-

Characteristics indicated on this data sheet are those that can be achieved with the highest performance cable. Intrinsic limitations of the cable may diminish the performance of the assembly

Cable retention

- pull off **204** N mini
- torque **NA** N.cm

MECHANICAL CHARACTERISTICS

Center contact retention		
Axial force – Mating end		27 N mini
Axial force – Opposite end		27 N mini
Torque		2.8 N.cm mini

Recommended torque

Mating	100 N.cm
Panel nut	NA N.cm
Clamp nut	NA N.cm
A/F clamp nut	0.000 mm

Mating life	500 Cycles mini
Weight	4.920 g

TOOLING

Part Number	Description	Hexagon
.	.	.
R282.223.000	CRIMPING TOOL	5.40
R282.235.011	CRIMPING DIES	5.40
R282.293.000	CRIMPING TOOL	-

OTHERS CHARACTERISTICS

-

ENVIRONMENTAL

Operating temperature	-65/+165 °C
Hermetic seal	NA Atm.cm3/s
Panel leakage	NA

Issue : 0311 U

In the effort to improve our products, we reserve the right to make changes judged to be necessary.

